

# Instructions—Parts List



## WALL MOUNT, 4-BALL 3:1 Ratio President® Pump Modules

308768J

EN

Used for low pressure, medium volume circulation of finishing materials. For professional use only.

Pump Modules are   certified.  
See page 2 for table of contents and list of Models.



### Important Safety Instructions

Read all warnings and instructions in this manual and in 4-Ball Pump manual 3A1450. Save all instructions.

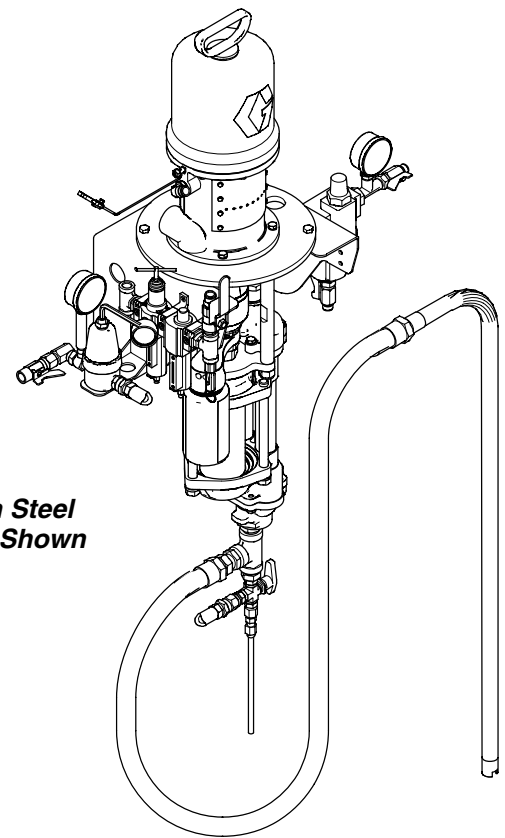

*232079 Carbon Steel  
Pump Module Shown*

ti17807a



PROVEN QUALITY. LEADING TECHNOLOGY.

# Table of Contents

List of Models .....	2	Technical Data .....	20
Warnings .....	3	Dimensions .....	22
Installation .....	6	Mounting Hole Layouts .....	23
Operation .....	11	Graco Warranty .....	24
Maintenance .....	14	Graco Information .....	24
Parts .....	16		

## List of Models

Part No.	Series	Description	Ratio	Maximum Fluid Working Pressure	Maximum Air Input Pressure
<b>Pump Modules</b>					
*232078	A	Stainless steel pump with wall bracket, air controls, back pressure regulator, and stainless steel fluid filter	3:1	300 psi (2.1 MPa, 21 bar)	100 psi (0.7 MPa, 7 bar)
*232079	A	Carbon steel pump with wall bracket, air controls, back pressure regulator, and Graco Red Alert® carbon steel fluid filter	3:1	300 psi (2.1 MPa, 21 bar)	100 psi (0.7 MPa, 7 bar)
*232081	A	Stainless steel pump with wall bracket, air controls, back pressure regulator, and stainless steel fluid filter	3:1	300 psi (2.1 MPa, 21 bar)	100 psi (0.7 MPa, 7 bar)

\*Pump modules are   certified.

# Symbols

## Warning Symbol



This symbol alerts you to the possibility of serious injury or death if you do not follow the instructions.

## Caution Symbol



This symbol alerts you to the possibility of damage to or destruction of equipment if you do not follow the instructions.

## WARNING



INSTRUCTIONS

### EQUIPMENT MISUSE HAZARD

Equipment misuse can cause the equipment to rupture or malfunction and result in serious injury.

- This equipment is for professional use only.
- Read all instruction manuals, tags, and labels before operating the equipment.
- Use the equipment only for its intended purpose. If you are uncertain about usage, call your Graco distributor.
- Do not alter or modify this equipment. Use only genuine Graco parts and accessories.
- Check equipment daily. Repair or replace worn or damaged parts immediately.
- Do not exceed the maximum working pressure stated on the equipment or in the **Technical Data** for your equipment. Do not exceed the maximum working pressure of the lowest rated component in your system.
- Use fluids and solvents which are compatible with the equipment wetted parts. Refer to the **Technical Data** section of all equipment manuals. Read the fluid and solvent manufacturer's warnings.
- Route hoses away from traffic areas, sharp edges, moving parts, and hot surfaces. Do not expose Graco hoses to temperatures above 180°F (82°C) or below -40°F (-40°C).
- Wear hearing protection when operating this equipment.
- Do not lift pressurized equipment.
- Comply with all applicable local, state, and national fire, electrical, and safety regulations.

# WARNING



## PRESSURIZED EQUIPMENT HAZARD

Spray from the gun, hose leaks, or ruptured components can splash fluid in the eyes or on the skin and cause serious injury.

- Do not point the gun at anyone or at any part of the body.
- Do not stop or deflect leaks with your hand, body, glove or rag.
- Follow the **Pressure Relief Procedure** on page 11 whenever you: are instructed to relieve pressure; stop spraying; clean, check, or service the equipment; and install or clean the spray tip.
- Tighten all fluid connections before operating the equipment.
- Check the hoses, tubes, and couplings daily. Replace worn, damaged, or loose parts immediately. Permanently coupled hoses cannot be repaired; replace the entire hose.



## MOVING PARTS HAZARD

Moving parts, such as the air motor piston, elevator, and agitator blades, can pinch or amputate your fingers.

- Keep clear of all moving parts when starting or operating the pump.
- Keep your hands away from the elevator, pump support, drum cover, and the lip of the drum while the elevator is operating or is charged with air.
- Always shut off the agitator and disconnect the air line before you remove the agitator from the drum or check or repair any part of the agitator.
- Before servicing the equipment, follow the **Pressure Relief Procedure** on page 11 to prevent the equipment from starting unexpectedly.

# WARNING



## FIRE AND EXPLOSION HAZARD

Improper grounding, poor ventilation, open flames or sparks can cause a hazardous condition and result in a fire or explosion and serious injury.

- Ground the equipment and the object being sprayed. Refer to **Grounding** on page 10.
- If there is any static sparking or you feel an electric shock while using this equipment, **stop spraying immediately**. Do not use the equipment until you identify and correct the problem.
- Provide fresh air ventilation to avoid the buildup of flammable fumes from solvents or the fluid being sprayed.
- Keep the spray area free of debris, including solvent, rags, and gasoline.
- Electrically disconnect all equipment in the spray area.
- Extinguish all open flames or pilot lights in the spray area.
- Do not smoke in the spray area.
- Do not turn on or off any light switch in the spray area while operating or if fumes are present.
- Do not operate a gasoline engine in the spray area.



## TOXIC FLUID HAZARD

Hazardous fluid or toxic fumes can cause serious injury or death if splashed in the eyes or on the skin, inhaled, or swallowed.

- Know the specific hazards of the fluid you are using.
- Store hazardous fluid in an approved container. Dispose of hazardous fluid according to all local, state, and national guidelines.
- Always wear protective eyewear, gloves, clothing, and respirator as recommended by the fluid and solvent manufacturer.

# Installation

## General Information

**NOTE:** Reference numbers and letters in parentheses in the text refer to the callouts in the figures and the parts drawing.

**NOTE:** Always use Genuine Graco Parts and Accessories, available from your Graco distributor. If you supply your own accessories, be sure they are adequately sized and pressure-rated for your system.

## Prepare the Operator

All persons who operate the equipment must be trained in the safe, efficient operation of all system components as well as the proper handling of all fluids. All operators must thoroughly read all instruction manuals, tags, and labels before operating the equipment.

The following manuals are included with this equipment:

- 3A1450, 3:1 President Pump
- 306982, President Air Motor
- 307273, 307282, or 308918, Fluid Filter
- 307068, Fluid Ball Valves
- 308401, Back Pressure Regulator

## Prepare the Site

Ensure that the wall is strong enough to support the weight of the pump and accessories, fluid, hoses, and stress caused during pump operation.

Ensure that you have an adequate compressed air supply. Refer to the performance chart on page 21 to find the air consumption.

Refer to Fig. 2 on page 9. Bring a compressed air supply line (A) from the air compressor to the pump location. Be sure all air hoses are properly sized and pressure-rated for your system. Use only electrically conductive hoses. The air hose should have a 3/8 npt(m) thread.

Install a bleed-type shutoff valve (B) in the air line to isolate the air line components for servicing. Install a moisture trap and drain valve (C) to help remove moisture and contaminants from the compressed air supply.

Keep the site clear of any obstacles or debris that could interfere with the operator's movement.

Have a grounded, metal pail available for use when flushing the system.

# Installation

## Supplied Components

Refer to Fig. 2 on page 9.

### **WARNING**

A red-handled bleed-type master air valve (11h) and a fluid drain valve (D) are supplied. These components help reduce the risk of serious injury, including splashing of fluid in the eyes or on the skin, and injury from moving parts if you are adjusting or repairing the pump.

The bleed-type master air valve relieves air trapped between this valve and the pump after the air is shut off. Trapped air can cause the pump to cycle unexpectedly. Locate the valve close to the pump.

The fluid drain valve assists in relieving fluid pressure in the displacement pump, hose, and gun. Triggering the gun to relieve pressure may not be sufficient.

- **The red-handled bleed-type master air valve (11h)** is required in your system to relieve air trapped between it and the air motor when the valve is closed (see the **WARNING** above). Be sure the bleed valve is easily accessible from the pump, and is located **downstream** from the pump air filter/regulator (11a).
- **The pump air filter/regulator (11a)** controls pump speed and outlet pressure by adjusting the air pressure to the pump. It includes an air filter with a 40 micron polypropylene element, to remove harmful dirt and moisture from the compressed air supply. Locate close to the pump, but **upstream** from the bleed-type master air valve (11h).

- **The air line lubricator (11b)** provides automatic lubrication of the air motor.
- **The air relief valve (11j)** opens automatically to prevent overpressurization of the pump.
- Fluid is supplied to the pump through the **suction hose (16) and tube (50)**. See Fig. 2.
- **The fluid filter (5)** includes a 60 mesh (250 micron) stainless steel element to filter particles from the fluid as it leaves the pump.
- **The fluid drain valve (D)**, is mounted in the bottom of the fluid filter bowl, and is required in your system to relieve fluid pressure in the hose and gun (see the **WARNING** at left).
- **The back pressure regulator (12)** controls back pressure to the gun and maintains proper circulation pressure.

## Conversion Modules

### Supply Module 239857

Part No. 239857 Supply Module is available to convert a pump module to a circulation package. The supply module includes an elevator, stainless steel drum cover, back-gearred agitator with suction tube, and connecting hardware. See manual 308769.

### Heater Modules 239850 (120V), 239851 (240V), and 239852 (220/240V)

Three Heater Modules are available to convert a pump module to a heated system. Each module includes a heater configured to the desired voltage, and mounting hardware. See manual 308771.

# Installation

## Installing the Pump Module

The pump module consists of the pump mounted on the pump bracket, the air controls, back pressure regulator, hoses, and plumbing.

**NOTE:** Refer to Fig. 2 on page 9, and to the Dimension drawing on page 22 and the Mounting Hole Layout on page 23.

1. Ensure that the wall is strong enough to support the weight of the pump and accessories, fluid, hoses, and stress caused during pump operation.
2. Position the bracket mounting plate (37) on the wall so the edge with the hook is facing up. Mount the plate so the top edge is 4 to 5 ft (1.2 to 1.5 m) above the floor. Check that the plate is level. Mark two holes on the wall, using the plate as a template. Drill two holes and attach the plate with 1/2 in. bolts and washers.
3. Using two people, hang the pump module on the bracket mounting plate (37). Have one person hold the module in place while the other checks that the pump bracket (22) is level. Mark four holes on the wall, using the pump bracket as a template. Remove the pump module.
4. Drill four holes in the wall.

### **WARNING**

The pump bracket (22) must be bolted to the wall with four bolts. Do not simply hang the pump bracket on the bracket mounting plate (37).

5. Lift the pump module back into position, hang it on the bracket mounting plate (37), and bolt the pump bracket (22) to the wall. Use 1/2 in. bolts and washers to mount the pump module to the wall. Use bolts that are long enough to keep the pump bracket (22) from vibrating during operation.

## Using the Quick Connectors

To open a quick connector (11c), loosen the captive screw (S) and open the connector. Slide the desired component into the connector, close, and tighten the screw. See Fig. 1.

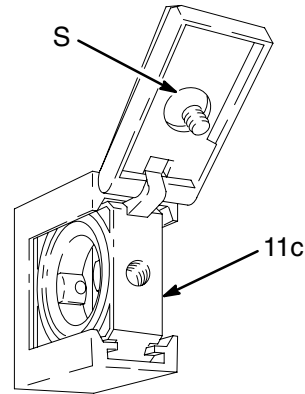

06278

**Fig. 1**

## Connect the Fluid Lines

Connect a 1 to 3 ft (0.3–0.9 m) hose (E) to the ball valve (15) at the outlet of the fluid filter (5), to isolate the pump module from the main fluid line. Connect the other end of the hose to the main fluid line (F).

Connect the fluid return line (G) to the ball valve (14) at the inlet of the back pressure regulator (12). The return hose (21) connects the back pressure regulator to the 3-way recirculation valve (19).

## Connect the Air Line

Connect the main air supply line (A) to the tee (11k) of the air filter/regulator/lubricator assembly (11).



# Installation

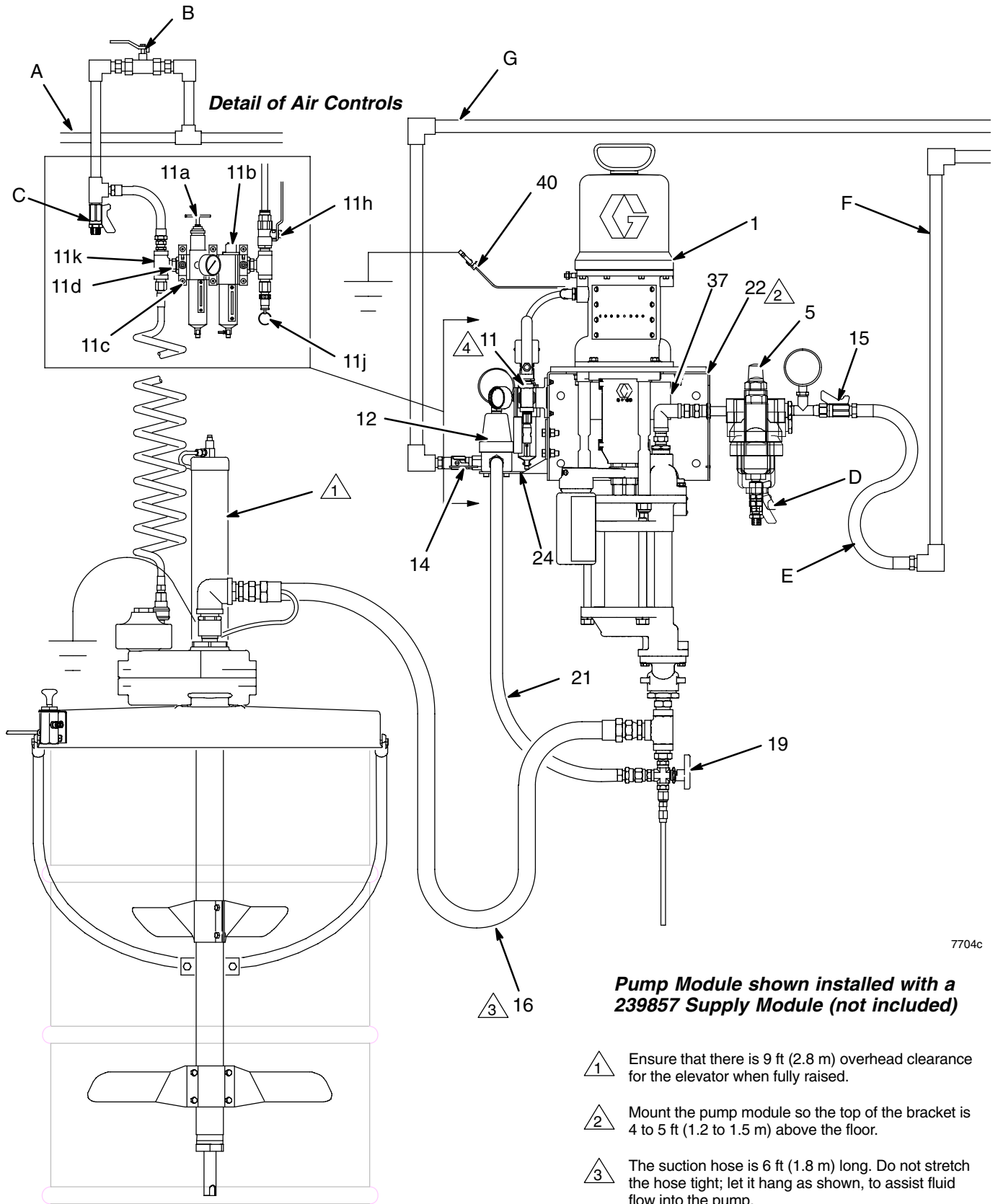

- 1 Ensure that there is 9 ft (2.8 m) overhead clearance for the elevator when fully raised.
- 2 Mount the pump module so the top of the bracket is 4 to 5 ft (1.2 to 1.5 m) above the floor.
- 3 The suction hose is 6 ft (1.8 m) long. Do not stretch the hose tight; let it hang as shown, to assist fluid flow into the pump.
- 4 See **Detail of Air Controls** in upper left corner.

**Fig. 2**

# Installation

## Grounding

**⚠ WARNING**

**FIRE AND EXPLOSION HAZARD**  
Before operating the pump, ground the system as explained below. Also read the section **FIRE AND EXPLOSION HAZARD** on page 5.

1. *Pump*: use the ground wire and clamp (40, supplied). See Fig. 3. Loosen the grounding lug locknut (W) and washer (X). Insert one end of the ground wire (40) into the slot in lug (Z) and tighten the locknut securely. Connect the ground clamp to a true earth ground.

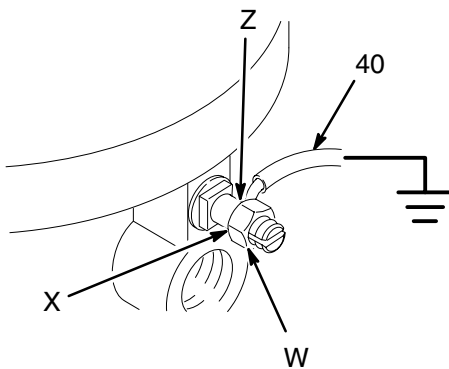

0720

Fig. 3

2. *Air and fluid hoses*: use only electrically conductive hoses.
3. *Air compressor*: follow manufacturer's recommendations.
4. *Spray gun*: ground through connection to a properly grounded fluid hose and pump.
5. *Suction hose*: attach the hose (16) ground wire to the fluid supply container.
6. *Fluid supply container*: follow your local code.
7. *Object being sprayed*: follow your local code.
8. *Solvent pails used when flushing*: follow your local code. Use only metal pails, which are conductive, placed on a grounded surface. Do not place the pail on a nonconductive surface, such as paper or cardboard, which interrupts the grounding continuity.
9. *To maintain grounding continuity when flushing or relieving pressure*, hold a metal part of the spray gun firmly to the side of a grounded *metal* pail, then trigger the gun.

# Operation

## Pressure Relief Procedure

### **WARNING**

#### **PRESSURIZED EQUIPMENT HAZARD**

The system pressure must be manually relieved to prevent the system from starting or spraying accidentally. To reduce the risk of an injury from accidental spray from the gun, splashing fluid, or moving parts, follow the **Pressure Relief Procedure** whenever you:

- are instructed to relieve the pressure,
- stop spraying,
- check or service any of the system equipment,
- or install or clean the spray nozzle.

1. Close the red-handled bleed-type master air valve (11h, required in your system). See Fig. 4 on page 13.
2. Place the drain hose (42) into a waste container. Turn the 3-way recirculation valve (19) to the drain position.
3. Trigger the gun at the last gun station to relieve fluid pressure. Maintain firm metal-to-metal contact between the gun and a grounded waste pail. Repeat for all gun stations.
4. Open the drain valve (D) to relieve fluid pressure which may be trapped in the pump or hose.

If you suspect that pressure is not fully relieved after following the steps above, wrap a fitting near the pump outlet with a rag, and slowly and carefully loosen the fitting to relieve pressure. Be careful to protect your eyes from splashing.

## Packing Nut

Before starting, fill the packing nut (H) 1/3 full with Graco Throat Seal Liquid (TSL) or compatible solvent. See Fig. 4 on page 13.

### **WARNING**

To reduce the risk of serious injury whenever you are instructed to relieve pressure, always follow the **Pressure Relief Procedure** at left.

The packing nut is torqued at the factory and is ready for operation. If it becomes loose and there is leaking from the throat packings, relieve pressure, then torque the nut to 34–40 N•m (25–30 ft-lb). Do this whenever necessary. Do not overtighten the packing nut.

## Flush the Pump Before First Use

The pump is tested with lightweight oil, which is left in to protect the pump parts. If the fluid you are using may be contaminated by the oil, flush it out with a compatible solvent. See **Flushing** on page 14.

# Operation

## Starting and Adjusting the Pump

1. Open all fluid shutoff valves (14, 15). Refer to Fig. 2 on page 9, and to Fig. 4.
2. Open the back pressure regulator (12). Turn the 3-way recirculation valve (19) to the circulation position.
3. Open the spray gun at the last gun station and keep it open while starting the pump.
4. Open the bleed-type master air valves (11h, B).
5. Slowly open the air filter/regulator (11a) until the pump starts. The air filter/regulator controls the pump speed and fluid outlet pressure.
6. Adjust the fluid pressure to the lowest setting necessary to get the desired results. Higher pressures may not improve the spray pattern and will cause premature component wear. Use the air filter/regulator (11a) and the back pressure regulator (12) to adjust the pump speed and fluid pressure until the spray is completely atomized. Refer to the back pressure valve manual (supplied) for adjustment procedures.
7. To adjust the spray pattern, follow the complete instructions in your gun manual.
8. When you have achieved the desired spray pattern, release the gun trigger. The pump will continue to cycle as long as air is supplied and the back pressure regulator (12) is open.
9. One at a time, open any other guns in the system to purge air from the lines.

**NOTE:** In a circulating system, the pump will continue to cycle as long as air is supplied and the back pressure regulator is open. In a direct supply system, the pump starts when the gun is opened, and stops when the gun is closed.

## WARNING



### COMPONENT RUPTURE HAZARD

To reduce the risk of overpressurizing your system, which could cause component rupture and serious injury, *never exceed the specified maximum air input pressure to the pump* (see **Technical Data** on page 20).

## CAUTION

Do not allow the pump to run dry. It will quickly accelerate to a high speed, causing damage. If your pump is running too fast, stop it immediately and check the fluid supply. If the container is empty and air has been pumped into the lines, refill the container and prime the pump and the lines, or flush and leave it filled with a compatible solvent. Eliminate all air from the fluid system.

## Shutdown

## WARNING

To reduce the risk of serious injury whenever you are instructed to relieve pressure, always follow the **Pressure Relief Procedure** on page 11.

Relieve the pressure.

For overnight shutdown, stop the pump at the bottom of its stroke to prevent fluid from drying on the exposed displacement rod and damaging the throat packings. Relieve the pressure.

Always flush the pump before the fluid dries on the displacement rod. See **Flushing** on page 14.

**NOTE:** When changing fluid containers with the hose and gun already primed, open the drain valve (D) to help prime the pump and vent air before it enters the hose. Close the drain valve when all air is eliminated.

# Operation

- 1  Torque packing nut (H) to 34–40 N•m (25–30 ft-lb).  
Packing nut is partially hidden.

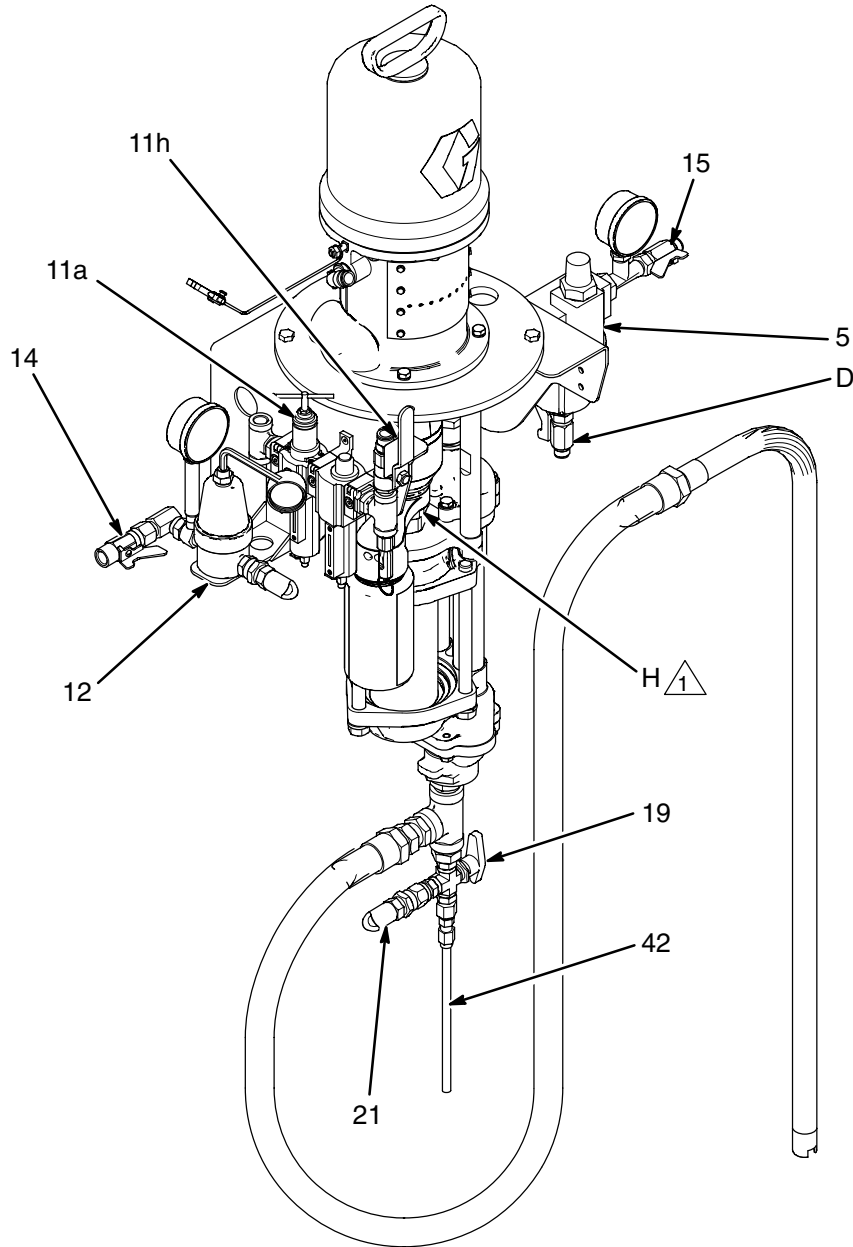

Fig. 4

ti17807a

# Maintenance

## Preventive Maintenance Schedule

The operating conditions of your particular system determine how often maintenance is required. Establish a preventive maintenance schedule by recording when and what kind of maintenance is needed, and then determine a regular schedule for checking your system.

## Flushing

### WARNING



#### FIRE AND EXPLOSION HAZARD

Before flushing, read the section **FIRE AND EXPLOSION HAZARD** on page 5. Be sure the entire system and flushing pails are properly grounded. Refer to **Grounding** on page 10.



Flush the pump:

- Before the first use
- When changing colors or fluids
- Before fluid can dry or settle out in a dormant pump (check the pot life of catalyzed fluids)
- Before storing the pump.

Flush with a fluid that is compatible with the fluid you are pumping and with the wetted parts in your system. Check with your fluid manufacturer or supplier for recommended flushing fluids and flushing frequency.

### CAUTION

If you have a carbon steel pump, never leave water or water-base fluid in the pump overnight. If you are pumping water-base fluid, flush with water first, then with a rust inhibitor such as mineral spirits. Relieve the pressure, but leave the rust inhibitor in the pump to protect the parts from corrosion.

### WARNING

To reduce the risk of serious injury whenever you are instructed to relieve pressure, always follow the **Pressure Relief Procedure** on page 11.

1. Relieve the pressure.
2. Remove the air cap and spray tip from the gun. See the gun manual.

3. Remove the filter element from the fluid filter (5). Reinstall the filter bowl.
4. Open the back pressure regulator (12). Set the 3-way recirculation valve (19) to the circulation position.
5. Place the suction tube (50) in a container of solvent.
6. Hold a metal part of the gun firmly to the side of a grounded *metal* pail.
7. Start the pump. Always use the lowest possible fluid pressure when flushing.
8. Trigger the gun. Flush the system until clear solvent flows from the gun.
9. Release the gun trigger and lock the trigger safety. The pump will continue to cycle as long as air is supplied and the back pressure regulator (12) is open.
10. Direct the drain hose (42) into a waste container. Set the 3-way recirculation valve (19) to the drain position. Continue flushing until clear fluid comes from the hose.
11. Relieve the pressure.
12. Clean the air cap, spray tip, and fluid filter element separately, then reinstall them.

## Air Filter Service

Repair Kits are available. Refer to page 15.

Every day, drain contaminants from the bowl before reaching the baffle level by opening the drain (P) at the bottom of the bowl (N).

### WARNING

To reduce the risk of serious injury whenever you are instructed to relieve pressure, always follow the **Pressure Relief Procedure** on page 11.

Clean the air filter regularly to maximize filtering efficiency and to avoid excessive pressure drop. Fully relieve pressure to remove the bowl (N).

Clean the filter element (211) and bowl using household soap and water or denatured alcohol. Use compressed air to blow out the filter body. Blow the filter element out from the inside.

Clean the sight glass (209) thoroughly. Do not leave solvent residue in the sight glass as it may attack or weaken the glass. If the sight glass appears damaged, replace it immediately.

# Maintenance

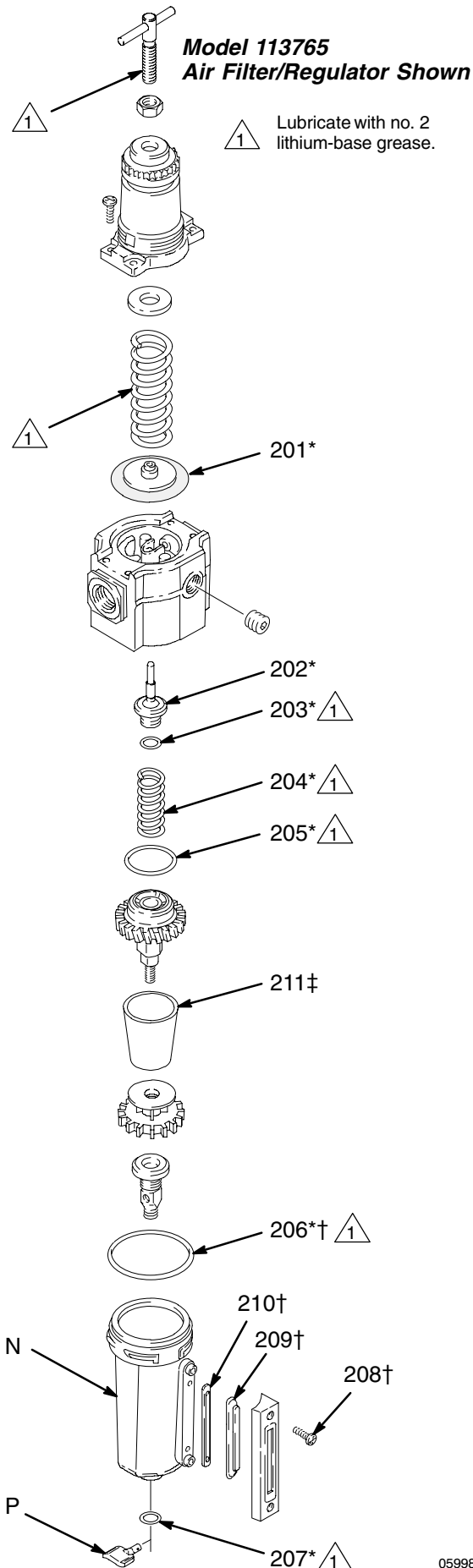

## Repair Kit 239383 (includes items 201 to 207). For Part No. 113765 Air Filter/Regulator.

Kit parts are marked with an asterisk (201\*). Individual parts are not available separately.

Ref. No.	Part No.	Description	Qty.
201*	N/A	DIAPHRAGM	1
202*	N/A	VALVE ASSEMBLY	1
203*	N/A	O-RING, valve	1
204*	N/A	SPRING, valve	1
205*	N/A	O-RING, center post	1
206*	N/A	O-RING, bowl assembly	1
207*	N/A	GASKET, drain	1

## Sight Glass Kit 239385 (includes items 206 to 210). For Part No. 113765 Air Filter/Regulator.

Kit parts are marked with a symbol (208†). Individual parts are not available separately.

Ref. No.	Part No.	Description	Qty.
206†	N/A	O-RING, bowl assembly	1
208†	N/A	SCREW	2
209†	N/A	LENS, sight glass	1
210†	N/A	SEAL, lens	1

## Filter Element Kit 239384 (includes item 211). For Part No. 113765 Air Filter/Regulator.

Kit parts are marked with a symbol (211‡). Individual parts are not available separately.

Ref. No.	Part No.	Description	Qty.
211‡	N/A	ELEMENT, 40 micron; polypropylene	1

05998

# Parts

Part No. 232078, Series B, stainless steel pump module

Part No. 232079, Series B, carbon steel pump module (shown)

Part No. 232081, Series B, stainless steel pump module

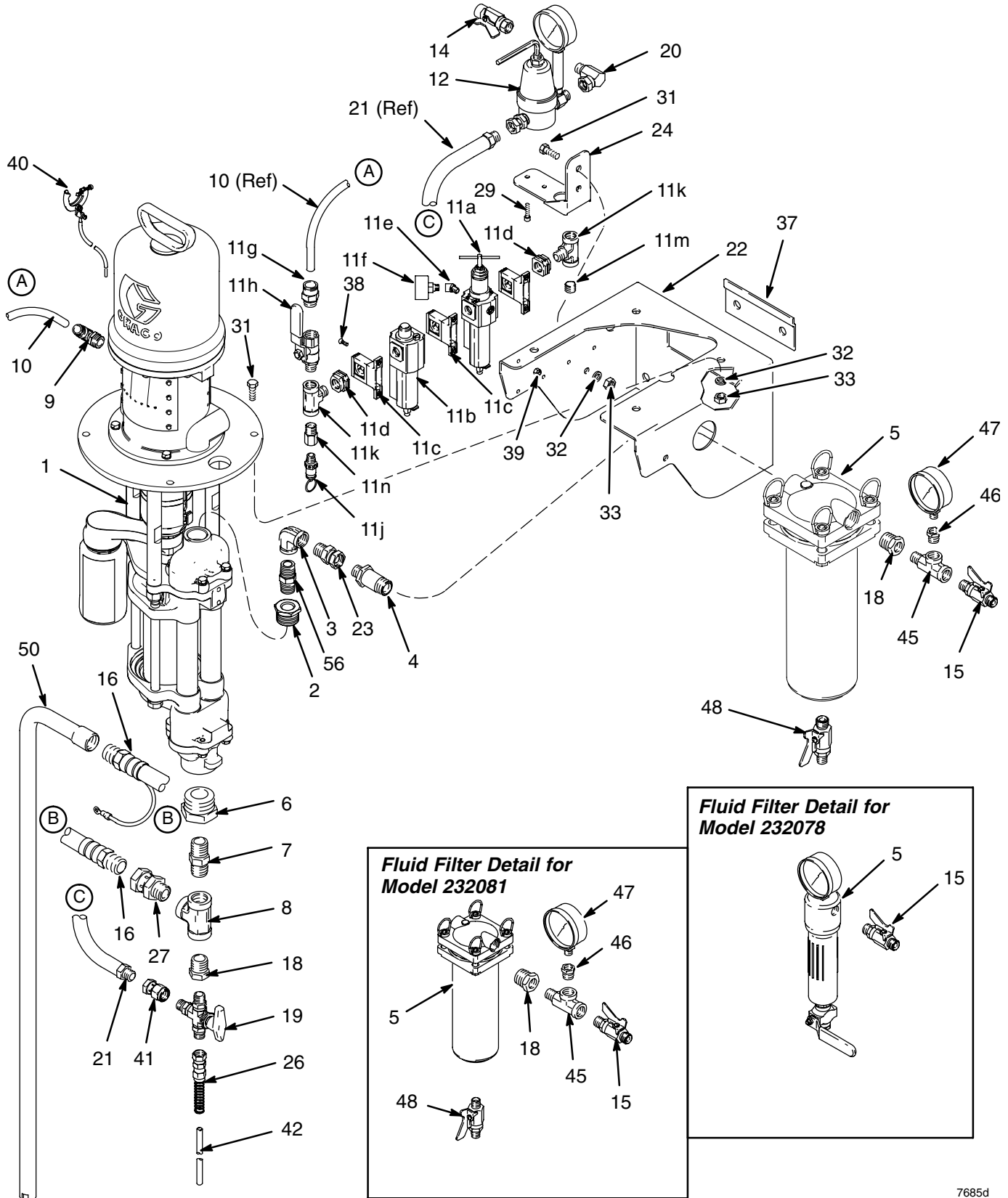

7685d



# Parts

**Part No. 232078, Series B, stainless steel pump module**

**Part No. 232079, Series B, carbon steel pump module (shown)**

**Part No. 232081, Series B, stainless steel pump module**

**NOTE:** Part numbers vary by module. To find the part number used in your module, read down the chart to find the desired ref. no., then read left to right to find the part number for your module.

Ref. No.	Description	Module			Qty
		232078 SST Module	232079 CST Module	232081 SST Module	
1	PUMP, President; 3:1 ratio; sst; <i>see manual 3A1450</i>	24J075		24J075	1
	PUMP, President; 3:1 ratio; cst; <i>see manual 3A1450</i>		24J074		1
2	BUSHING; sst; 1" npt(m) x 1/2 npt(f)	513299	513299	513299	1
3	ELBOW, 90°; sst; 1/2 npt(fbe)	500947	500947	500947	1
4	NIPPLE, reducing; sst; 1/2 npt x 3/8 npt	111874			1
	NIPPLE, reducing; sst; 3/4 npt x 1/2 npt		192593	192593	1
5	FLUID FILTER, includes drain valve and gauge; sst; <i>see manual 307273</i>	239853			1
	FLUID FILTER; sst; <i>see manual 307282</i>		213058		1
	FLUID FILTER; sst; <i>see manual 308918</i>			244053	1
6	BUSHING; sst; 1-1/2" npt(m) x 3/4 npt(f)	114188	114188	114188	1
7	NIPPLE; sst; 3/4 npt	510073	510073	510073	1
8	TEE; sst; 3/4 npt(f) run x 3/4 npt(f) branch	113833	113833	113833	1
9	ELBOW, tube fitting, 90°; 1/2 npt(m) x 1/2 in. (13 mm) OD tube	114110	114110	114110	1
10	HOSE; polyurethane; 0.328 in. (8 mm) ID; 13 in. (330 mm) long	Purchase locally	Purchase locally	Purchase locally	1
11	AIR FILTER/REGULATOR/LUBRICATOR; <i>see page 15; includes items 11a to 11m</i>	239849	239849	239849	1
11a	. AIR FILTER/REGULATOR	113765	113765	113765	1
11b	. LUBRICATOR	114005	114005	114005	1
11c	. CONNECTOR, quick	113763	113763	113763	3
11d	. ADAPTER, pipe; 3/8 npt(f)	113767	113767	113767	2
11e	. ELBOW, 45°; 1/8 npt (m x f)	113630	113630	113760	1
11f	. GAUGE, air	113911	113911	113911	1
11g	. ADAPTER, tube fitting; 1/2 npt(m) x 1/2 in. (13 mm) OD tube	114129	114129	114129	1
11h	. VALVE, ball, bleed-type; 3/8 npt (m x f)	113333	113333	113333	1
11j	. VALVE, relief; 110 psi (7.6 bar, 0.76 MPa)	113498	113498	113498	1
11k	. TEE; 3/8 npt(f) run x 3/8 npt(m) branch	113777	113777	113777	2
11m	. PLUG; 3/8 npt	101754	101754	101754	1
11n	. ADAPTER; 3/8 npt(m) x 1/4 npt(f)	159841	159841	159841	1
12	REGULATOR, back pressure; <i>see manual 308401</i>	236770	236770	236770	1
14	VALVE, ball; sst; 3/8 npt(fbe); <i>see manual 307068</i>	237532	237532	237532	1
15	VALVE, ball; sst; 1/4 npt(m) x 3/8 npsm(m); <i>see manual 307068</i>	237529			1
	VALVE, ball; sst; 3/8 npt(m) x 3/8 npsm(m); <i>see manual 307068</i>		237533	237533	1

**NOTE:** The Parts List is continued on page 18.

# Parts

**Part No. 232078, Series B, stainless steel pump module**

**Part No. 232079, Series B, carbon steel pump module**

**Part No. 232081, Series B, stainless steel pump module**

**NOTE:** Part numbers vary by module. To find the part number used in your module, read down the chart to find the desired ref. no., then read left to right to find the part number for your module.

Ref. No.	Description	Module			Qty
		232078 SST Module	232079 CST Module	232081 SST Module	
16	HOSE, suction, with ground wire; nylon; 3/4 npt(mbe) sst couplings; 1/2 in. (13 mm) ID; 6 ft (1.8 m) long	221171	221171	221171	1
18	BUSHING; sst; 3/4 npt(m) x 3/8 npt(f)	500352			1
	BUSHING; sst; 3/4 npt(m) x 3/8 npt(f)		500352	500352	2
19	VALVE, recirculation, 3-way; sst; 3/8 npt(m)	114189	114189	114189	1
20	SWIVEL, 90°; sst; 3/8 npt(m) x 3/8 npsm(f)	207123	207123	207123	1
21	HOSE, fluid return; nylon; 3/8 npt(mbe) sst couplings; 1/4" (6 mm) ID; 6 ft (1.8 m) long	114198	114198	114198	1
22	BRACKET, pump	192584	192584	192584	1
23	UNION, swivel; 1/2 npt(m) x 1/2 npsm(f); sst	114190	114190	114190	1
24	BRACKET, back pressure regulator	192586	192586	192586	1
26	COUPLING, hose, with spring guard; sst; 3/8 npsm(f)	111914	111914	111914	1
27	SWIVEL; 3/4 npt (m x f); sst	112268	112268	112268	1
29	SCREW, cap, socket hd; 1/4–20; 1/2 in. (13 mm) long	101550	101550	101550	2
31	SCREW, cap, hex head; 3/8–16 x 1 in. (25 mm) long	102471	102471	102471	5
32	LOCKWASHER, spring; 3/8	103975	103975	103975	5
33	NUT, hex; 3/8–16	112913	112913	112913	5
37	PLATE, mounting, bracket	192589	192589	192589	1
38	SCREW, machine, socket, flat head; M5 x 0.8; 16 mm long	113768	113768	113768	6
39	NUT, hex, with nylon insert; M5 x 0.8	105332	105332	105332	6
40	GROUND WIRE AND CLAMP	237569	237569	237569	1
41	SWIVEL, straight; 3/8 npt(f) x 3/8 npsm(f)	207152	207152	207152	1
42	TUBE, drain; nylon; 1/4 in. (6 mm) ID; 8 in. (203 mm) long	Purchase locally	Purchase locally	Purchase locally	1
45	TEE; sst; 3/8 npt(f) x 3/8 npt(m) run; 3/8 npt(f) branch		108673	108673	1
46	BUSHING; sst; 3/8 npt(m) x 1/4 npt(f)		168160	168160	1
47	GAUGE, fluid pressure; sst; 0–300 psi (0–21 bar, 0–2.1 MPa)		187876	187876	1
48	VALVE, ball; sst; 1/4 npt(m) x 3/8 npsm(m); <i>see manual 307068</i>		237529	237529	1
49	THROAT SEAL LIQUID; 1 pint (0.5 liter); not shown	206994	206994	206994	1
50	TUBE, suction, 90°; sst; 3/4 npt(f) x 3/4 npsm(m)	188867	188867	188867	1
56	NIPPLE; sst; 1/2 npt	114373	114373	114373	1



# Technical Data

Part No. 232078, Series B, stainless steel pump module

Part No. 232079, Series B, carbon steel pump module

Part No. 232081, Series B, stainless steel pump module

Category	Data
Maximum fluid working pressure	300 psi (2.1 MPa, 21 bar)
Maximum air input pressure	100 psi (0.7 MPa, 7 bar)
Ratio	3:1
Maximum operating temperature	<i>Models 232078 and 232079:</i> 180°F (82°C) <i>Model 232081:</i> 150°F (66°C)
Weight	<i>Stainless steel models:</i> 114 lb (52.7 kg) <i>Carbon steel models:</i> 112 lb (51.8 kg)
Wetted parts	<i>Pump:</i> See pump manual 308793. <i>Fluid Filter:</i> See filter manual 307273, 307282, or 308918. <i>Back Pressure Regulator:</i> See back pressure regulator manual 308401. <i>Fluid Hoses:</i> Nylon

## Sound Pressure Levels (dBa)

(measured at 1 meter from unit)

Air Motor	Input Air Pressures at 15 cycles per minute		
	40 psi (0.28 MPa, 2.8 bar)	70 psi (0.48 MPa, 4.8 bar)	100 psi (0.7 MPa, 7 bar)
President	73.6 dB(A)	78.3 dB(A)	80.9 dB(A)

## Sound Power Levels (dBa)

(tested in accordance with ISO 9614–2)

Air Motor	Input Air Pressures at 15 cycles per minute		
	40 psi (0.28 MPa, 2.8 bar)	70 psi (0.48 MPa, 4.8 bar)	100 psi (0.7 MPa, 7 bar)
President	87.4 dB(A)	92.1 dB(A)	94.6 dB(A)

# Technical Data

## Fluid Outlet Pressure Chart

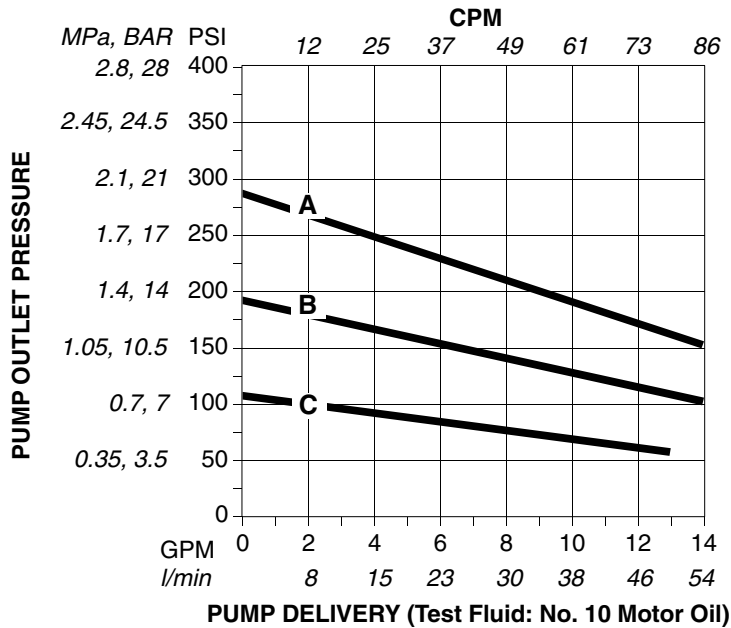

- A** 0.7 MPa, 7 bar (100 psi) air pressure
- B** 0.49 MPa, 4.9 bar (70 psi) air pressure
- C** 0.28 MPa, 2.8 bar (40 psi) air pressure

**To find Outlet Pressure** (MPa/bar/psi) at a specific delivery (liter/min or gpm) and operating air pressure (MPa/bar/psi):

1. Locate desired delivery along bottom of chart.
2. Read vertical line up to intersection with selected fluid outlet pressure curve (black curves). Curve slopes from left to right. Follow left to scale and read outlet pressure.

## Air Consumption Chart

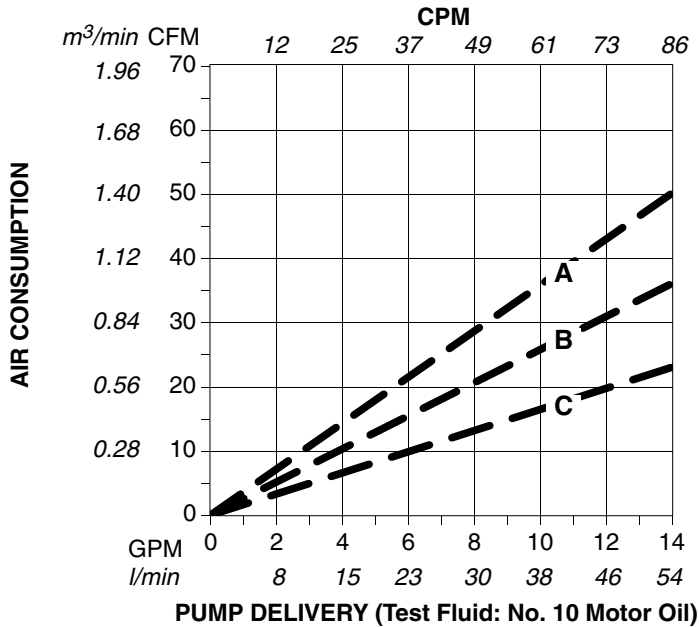

- A** 0.7 MPa, 7 bar (100 psi) air pressure
- B** 0.49 MPa, 4.9 bar (70 psi) air pressure
- C** 0.28 MPa, 2.8 bar (40 psi) air pressure

**To find Pump Air Consumption** (m<sup>3</sup>/min or CFM/min) at a specific delivery (liter/min or gpm) and operating air pressure (MPa/bar/psi):

1. Locate desired delivery along bottom of chart.
2. Read vertical line up to intersection with selected air consumption curve (dashes). Curve slopes from right to left. Follow left to scale and read air consumption.

# Dimensions

2 Mount the pump module so the top of the bracket is 4 to 5 ft (1.2 to 1.5 m) above the floor.

3 The suction hose is 6 ft (1.8 m) long. Do not stretch the hose tight; let it hang as shown, to assist fluid flow into the pump.

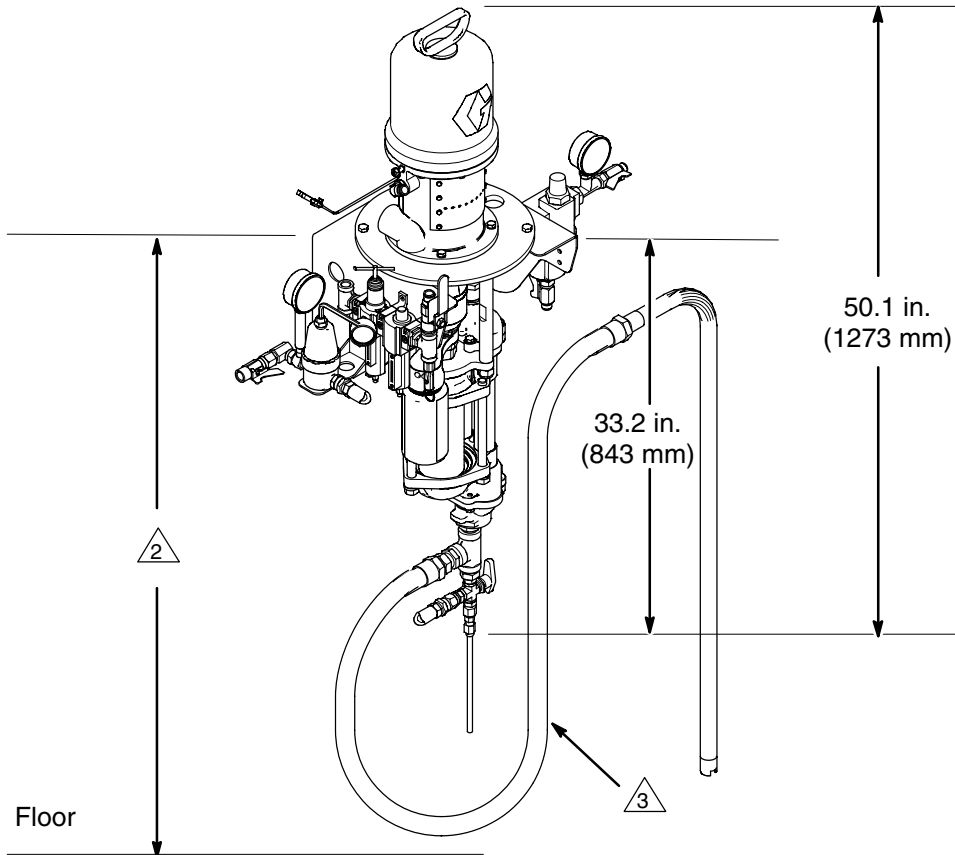

ti17807a

# Mounting Hole Layout

- 1 Check that the bracket is level before bolting it to the wall.
- 2 Mount the bracket so the top edge is 4 to 5 ft (1.2 to 1.5 m) above the floor.

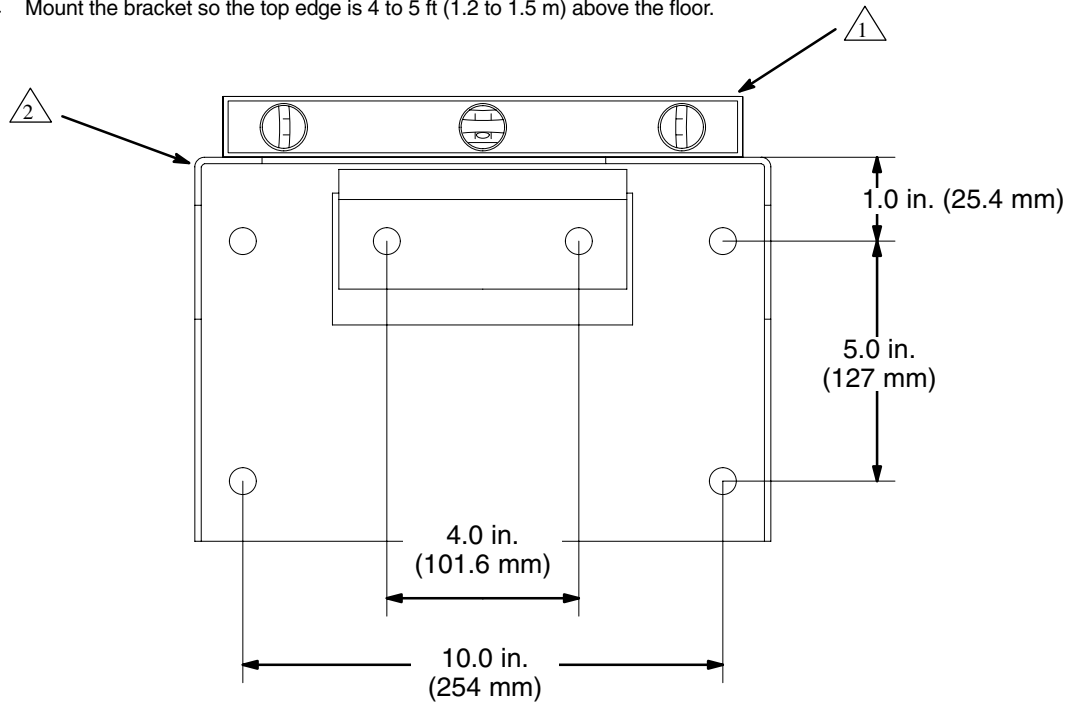

7687A

# Graco Standard Warranty

Graco warrants all equipment manufactured by Graco and bearing its name to be free from defects in material and workmanship on the date of sale to the original purchaser for use. With the exception of any special, extended, or limited warranty published by Graco, Graco will, for a period of twelve months from the date of sale, repair or replace any part of the equipment determined by Graco to be defective. This warranty applies only when the equipment is installed, operated and maintained in accordance with Graco's written recommendations.

This warranty does not cover, and Graco shall not be liable for general wear and tear, or any malfunction, damage or wear caused by faulty installation, misapplication, abrasion, corrosion, inadequate or improper maintenance, negligence, accident, tampering, or substitution of non-Graco component parts. Nor shall Graco be liable for malfunction, damage or wear caused by the incompatibility of Graco equipment with structures, accessories, equipment or materials not supplied by Graco, or the improper design, manufacture, installation, operation or maintenance of structures, accessories, equipment or materials not supplied by Graco.

This warranty is conditioned upon the prepaid return of the equipment claimed to be defective to an authorized Graco distributor for verification of the claimed defect. If the claimed defect is verified, Graco will repair or replace free of charge any defective parts. The equipment will be returned to the original purchaser transportation prepaid. If inspection of the equipment does not disclose any defect in material or workmanship, repairs will be made at a reasonable charge, which charges may include the costs of parts, labor, and transportation.

**THIS WARRANTY IS EXCLUSIVE, AND IS IN LIEU OF ANY OTHER WARRANTIES, EXPRESS OR IMPLIED, INCLUDING BUT NOT LIMITED TO WARRANTY OF MERCHANTABILITY OR WARRANTY OF FITNESS FOR A PARTICULAR PURPOSE.**

Graco's sole obligation and buyer's sole remedy for any breach of warranty shall be as set forth above. The buyer agrees that no other remedy (including, but not limited to, incidental or consequential damages for lost profits, lost sales, injury to person or property, or any other incidental or consequential loss) shall be available. Any action for breach of warranty must be brought within two (2) years of the date of sale.

Graco makes no warranty, and disclaims all implied warranties of merchantability and fitness for a particular purpose in connection with accessories, equipment, materials or components sold but not manufactured by Graco. These items sold, but not manufactured by Graco (such as electric motors, switches, hose, etc.), are subject to the warranty, if any, of their manufacturer. Graco will provide purchaser with reasonable assistance in making any claim for breach of these warranties.

In no event will Graco be liable for indirect, incidental, special or consequential damages resulting from Graco supplying equipment hereunder, or the furnishing, performance, or use of any products or other goods sold hereto, whether due to a breach of contract, breach of warranty, the negligence of Graco, or otherwise.

## **FOR GRACO CANADA CUSTOMERS**

The parties acknowledge that they have required that the present document, as well as all documents, notices and legal proceedings entered into, given or instituted pursuant hereto or relating directly or indirectly hereto, be drawn up in English. Les parties reconnaissent avoir convenu que la rédaction du présente document sera en Anglais, ainsi que tous documents, avis et procédures judiciaires exécutés, donnés ou intentés à la suite de ou en rapport, directement ou indirectement, avec les procédures concernées.

## Graco Information

For the latest information about Graco products, visit [www.graco.com](http://www.graco.com).

**TO PLACE AN ORDER**, contact your Graco distributor or call to identify the distributor closest to you:

**Phone:** 612-623-6921 or **Toll Free:** 1-800-328-0211 **Fax:** 612-378-3505

*All written and visual data contained in this document reflects the latest product information available at the time of publication.  
Graco reserves the right to make changes at any time without notice.*

Original instructions. This manual contains English. MM 308768

**Graco Headquarters:** Minneapolis

**International Offices:** Belgium, China, Japan, Korea

**GRACO INC. P.O. BOX 1441 MINNEAPOLIS, MN 55440-1441**

Copyright 1997, Graco Inc. is registered to ISO 9001

[www.graco.com](http://www.graco.com)

Revised 08/2011



## Free Manuals Download Website

<http://myh66.com>

<http://usermanuals.us>

<http://www.somanuals.com>

<http://www.4manuals.cc>

<http://www.manual-lib.com>

<http://www.404manual.com>

<http://www.luxmanual.com>

<http://aubethermostatmanual.com>

Golf course search by state

<http://golfingnear.com>

Email search by domain

<http://emailbydomain.com>

Auto manuals search

<http://auto.somanuals.com>

TV manuals search

<http://tv.somanuals.com>