

10" Professional Table Saw

(Model 36-650)

INSTRUCTION MANUAL



PART NO. 902113 - 11-22-02
Copyright © 2002 Delta Machinery

 **DELTA[®] INDUSTRIAL**

To learn more about DELTA MACHINERY
visit our website at: www.deltamachinery.com.

For Parts, Service, Warranty or other Assistance,

please call **1-800-223-7278** (In Canada call **1-800-463-3582**).

SAFETY GUIDELINES / DEFINITIONS

This manual contains information that is important for you to know and understand. This information relates to protecting YOUR SAFETY and PREVENTING EQUIPMENT PROBLEMS. To help you recognize this information, we use the symbols to the right. Please read the manual and pay attention to these sections.

▲ DANGER Indicates an imminently hazardous situation which, if not avoided, will result in death or serious injury.

▲ WARNING Indicates a potentially hazardous situation which, if not avoided, could result in death or serious injury.

▲ CAUTION Indicates a potentially hazardous situation which, if not avoided, may result in minor or moderate injury

CAUTION Used without the safety alert symbol indicates potentially hazardous situation which, if not avoided, may result in property damage.

▲ WARNING **SOME DUST CREATED BY POWER SANDING, SAWING, GRINDING, DRILLING, AND OTHER CONSTRUCTION ACTIVITIES** contains chemicals known to cause cancer, birth defects or other reproductive harm. Some examples of these chemicals are:

- lead from lead-based paints,
- crystalline silica from bricks and cement and other masonry products, and
- arsenic and chromium from chemically-treated lumber.

Your risk from these exposures varies, depending on how often you do this type of work. To reduce your exposure to these chemicals: work in a well ventilated area, and work with approved safety equipment, such as those dust masks that are specially designed to filter out microscopic particles.

GENERAL SAFETY RULES

Woodworking can be dangerous if safe and proper operating procedures are not followed. As with all machinery, there are certain hazards involved with the operation of the product. Using the machine with respect and caution will considerably lessen the possibility of personal injury. However, if normal safety precautions are overlooked or ignored, personal injury to the operator may result. Safety equipment such as guards, push sticks, hold-downs, featherboards, goggles, dust masks and hearing protection can reduce your potential for injury. But even the best guard won't make up for poor judgment, carelessness or inattention. Always use common sense and exercise caution in the workshop. If a procedure feels dangerous, don't try it. Figure out an alternative procedure that feels safer. **REMEMBER:** Your personal safety is your responsibility.

This machine was designed for certain applications only. Delta Machinery strongly recommends that this machine not be modified and/or used for any application other than that for which it was designed. If you have any questions relative to a particular application, **DO NOT** use the machine until you have first contacted Delta to determine if it can or should be performed on the product.

Technical Service Manager
Delta Machinery
4825 Highway 45 North
Jackson, TN 38305
(IN CANADA: 505 SOUTHGATE DRIVE, GUELPH, ONTARIO N1H 6M7)

▲ WARNING Read Operator's Manual. Do not operate equipment until you have read Operator's Manual for **Safety, Assembly, Operation, and Maintenance Instructions.**

▲ WARNING **FAILURE TO FOLLOW THESE RULES MAY RESULT IN SERIOUS PERSONAL INJURY**

1. **FOR YOUR OWN SAFETY, READ INSTRUCTION MANUAL BEFORE OPERATING THE TOOL.** Learn the tool's application and limitations as well as the specific hazards peculiar to it.

2. **KEEP GUARDS IN PLACE** and in working order.

3. **ALWAYS WEAR EYE PROTECTION.** Wear safety glasses. Everyday eyeglasses only have impact resistant lenses; they are not safety glasses. Also use face or dust mask if cutting operation is dusty. These safety glasses must conform to ANSI Z87.1 requirements. **NOTE:** Approved glasses have Z87 printed or stamped on them.

4. **REMOVE ADJUSTING KEYS AND WRENCHES.** Form habit of checking to see that keys and adjusting wrenches are removed from tool before turning it "on".

5. **KEEP WORK AREA CLEAN.** Cluttered areas and benches invite accidents.

6. **DON'T USE IN DANGEROUS ENVIRONMENT.** Don't use power tools in damp or wet locations, or expose them to rain. Keep work area well-lighted.

7. **KEEP CHILDREN AND VISITORS AWAY.** All children and visitors should be kept a safe distance from work area.

8. **MAKE WORKSHOP CHILDPROOF** – with padlocks, master switches, or by removing starter keys.

9. **DON'T FORCE TOOL.** It will do the job better and be safer at the rate for which it was designed.

10. **USE RIGHT TOOL.** Don't force tool or attachment to do a job for which it was not designed.

11. **WEAR PROPER APPAREL.** No loose clothing, gloves, neckties, rings, bracelets, or other jewelry to get caught in moving parts. Nonslip footwear is recommended. Wear protective hair covering to contain long hair.

12. **SECURE WORK.** Use clamps or a vise to hold work when practical. It's safer than using your hand and frees both hands to operate tool.

13. **DON'T OVERREACH.** Keep proper footing and balance at all times.

14. **MAINTAIN TOOLS IN TOP CONDITION.** Keep tools sharp and clean for best and safest performance. Follow instructions for lubricating and changing accessories.

15. **DISCONNECT TOOLS** before servicing and when changing accessories such as blades, bits, cutters, etc.

16. **USE RECOMMENDED ACCESSORIES.** The use of accessories and attachments not recommended by Delta may cause hazards or risk of injury to persons.

17. **REDUCE THE RISK OF UNINTENTIONAL STARTING.** Make sure switch is in "OFF" position before plugging in power cord. In the event of a power failure, move switch to the "OFF" position.
18. **NEVER STAND ON TOOL.** Serious injury could occur if the tool is tipped or if the cutting tool is accidentally contacted.
19. **CHECK DAMAGED PARTS.** Before further use of the tool, a guard or other part that is damaged should be carefully checked to ensure that it will operate properly and perform its intended function – check for alignment of moving parts, binding of moving parts, breakage of parts, mounting, and any other conditions that may affect its operation. A guard or other part that is damaged should be properly repaired or replaced.
20. **DIRECTION OF FEED.** Feed work into a blade or cutter against the direction of rotation of the blade or cutter only.

21. **NEVER LEAVE TOOL RUNNING UNATTENDED. TURN POWER OFF.** Don't leave tool until it comes to a complete stop.
22. **STAY ALERT, WATCH WHAT YOU ARE DOING, AND USE COMMON SENSE WHEN OPERATING A POWER TOOL. DO NOT USE TOOL WHILE TIRED OR UNDER THE INFLUENCE OF DRUGS, ALCOHOL, OR MEDICATION.** A moment of inattention while operating power tools may result in serious personal injury.
23. **MAKE SURE TOOL IS DISCONNECTED FROM POWER SUPPLY** while motor is being mounted, connected or reconnected.
24. **THE DUST GENERATED** by certain woods and wood products can be injurious to your health. Always operate machinery in well ventilated areas and provide for proper dust removal. Use wood dust collection systems whenever possible.

ADDITIONAL SAFETY RULES FOR TABLE SAWS

⚠ WARNING FAILURE TO FOLLOW THESE RULES MAY RESULT IN SERIOUS PERSONAL INJURY.

1. **DO NOT OPERATE THIS MACHINE** until it is **assembled** and **installed** according to the instructions.
2. **OBTAIN ADVICE FROM YOUR SUPERVISOR, instructor, or another qualified person** if you are not familiar with the operation of this machine.
3. **FOLLOW ALL WIRING CODES** and recommended electrical connections.
4. **USE THE GUARDS WHENEVER POSSIBLE.** Check to see that they are in place, secured, and working correctly.
5. **AVOID KICKBACK by:**
 - A. keeping blade sharp and free of rust and pitch.
 - B. keeping rip fence parallel to the saw blade.
 - C. using saw blade guard and spreader for every possible operation, including all through sawing.
 - D. pushing the workpiece past the saw blade prior to release.
 - E. never ripping a workpiece that is twisted or warped, or does not have a straight edge to guide along the fence.
 - F. using featherboards when the anti-kickback device cannot be used.
 - G. never sawing a large workpiece that cannot be controlled.
 - H. never using the fence as a guide when crosscutting.
 - I. never sawing a workpiece with loose knots or other flaws.
6. **ALWAYS USE GUARDS, SPLITTER, AND ANTI-KICKBACK FINGERS** except when otherwise directed in the manual.
7. **REMOVE CUT-OFF PIECES AND SCRAPS** from the table before starting the saw. The vibration of the machine may cause them to move into the saw blade and be thrown out. After cutting, turn the machine off. When the blade has **come to a complete stop, remove all debris.**
8. **NEVER START THE MACHINE** with the workpiece against the blade.
9. **HOLD THE WORKPIECE FIRMLY** against the miter gauge or fence.
10. **NEVER** run the workpiece between the fence and a moulding cutterhead.
11. **NEVER** perform "free-hand" operations. Use either the fence or miter gauge to position and guide the workpiece.
12. **USE PUSH STICK(S)** for ripping a narrow workpiece.
13. **AVOID AWKWARD OPERATIONS AND HAND POSITIONS** where a sudden slip could cause a hand to move into the blade.
14. **KEEP ARMS, HANDS, AND FINGERS** away from the blade.
15. **NEVER** have any part of your body in line with the path of the saw blade.
16. **NEVER REACH AROUND** or over the saw blade.
17. **NEVER** attempt to free a stalled saw blade without first turning the machine "OFF".
18. **PROPERLY SUPPORT LONG OR WIDE** workpieces.
19. **NEVER PERFORM LAYOUT,** assembly or set-up work on the table/work area when the machine is running.
20. **TURN THE MACHINE "OFF" AND DISCONNECT THE MACHINE** from the power source before installing or removing accessories, before adjusting or changing set-ups, or when making repairs.
21. **TURN THE MACHINE "OFF",** disconnect the machine from the power source, and clean the table/work area before leaving the machine. **LOCK THE SWITCH IN THE "OFF" POSITION** to prevent unauthorized use.
22. **ADDITIONAL INFORMATION** regarding the safe and proper operation of this tool is available from the Power Tool Institute, 1300 Summer Avenue, Cleveland, OH 44115-2851. Information is also available from the National Safety Council, 1121 Spring Lake Drive, Itasca, IL 60143-3201. Please refer to the American National Standards Institute ANSI 01.1 Safety Requirements for Woodworking Machines and the U.S. Department of Labor OSHA 1910.213 Regulations.

SAVE THESE INSTRUCTIONS.

Refer to them often and use them to instruct others.

POWER CONNECTIONS

A separate electrical circuit should be used for your machines. This circuit should not be less than #12 wire and should be protected with a 20 Amp time lag fuse. If an extension cord is used, use only 3-wire extension cords which have 3-prong grounding type plugs and matching receptacle which will accept the machine's plug. Before connecting the machine to the power line, make sure the switch (s) is in the "OFF" position and be sure that the electric current is of the same characteristics as indicated on the machine. All line connections should make good contact. Running on low voltage will damage the machine.

⚠ DANGER DO NOT EXPOSE THE MACHINE TO RAIN OR OPERATE THE MACHINE IN DAMP LOCATIONS.

MOTOR SPECIFICATIONS

Your machine is wired for 120 volt, 60 HZ alternating current. Before connecting the machine to the power source, make sure the switch is in the "OFF" position.

GROUNDING INSTRUCTIONS

⚠ DANGER THIS MACHINE MUST BE GROUNDED WHILE IN USE TO PROTECT THE OPERATOR FROM ELECTRIC SHOCK.

1. All grounded, cord-connected machines:

In the event of a malfunction or breakdown, grounding provides a path of least resistance for electric current to reduce the risk of electric shock. This machine is equipped with an electric cord having an equipment-grounding conductor and a grounding plug. The plug must be plugged into a matching outlet that is properly installed and grounded in accordance with all local codes and ordinances.

Do not modify the plug provided - if it will not fit the outlet, have the proper outlet installed by a qualified electrician.

Improper connection of the equipment-grounding conductor can result in risk of electric shock. The conductor with insulation having an outer surface that is green with or without yellow stripes is the equipment-grounding conductor. If repair or replacement of the electric cord or plug is necessary, do not connect the equipment-grounding conductor to a live terminal.

Check with a qualified electrician or service personnel if the grounding instructions are not completely understood, or if in doubt as to whether the machine is properly grounded.

Use only 3-wire extension cords that have 3-prong grounding type plugs and matching 3-conductor receptacles that accept the machine's plug, as shown in Fig. A.

Repair or replace damaged or worn cord immediately.

2. Grounded, cord-connected machines intended for use on a supply circuit having a nominal rating less than 150 volts:

If the machine is intended for use on a circuit that has an outlet that looks like the one illustrated in Fig. A, the machine will have a grounding plug that looks like the plug illustrated in Fig. A. A temporary adapter, which looks like the adapter illustrated in Fig. B, may be used to connect this plug to a matching 2-conductor receptacle as shown in Fig. B if a properly grounded outlet is not available. The temporary adapter should be used only until a properly grounded outlet can be installed by a qualified electrician. The green-colored rigid ear, lug, and the like, extending from the adapter must be connected to a permanent ground such as a properly grounded outlet box. Whenever the adapter is used, it must be held in place with a metal screw.

NOTE: In Canada, the use of a temporary adapter is not permitted by the Canadian Electric Code.

3. **240 VOLT SINGLE PHASE OPERATION:**

The motor supplied with your saw is a dual voltage, 120/240 volt motor. If it is desired to operate your saw at 240 volts, single phase, it is necessary to reconnect the motor leads in the motor junction box by following the instructions given on the motor nameplate.

⚠ WARNING MAKE SURE MOTOR IS DISCONNECTED FROM POWER SOURCE BEFORE RECONNECTING MOTOR LEADS. It is also necessary to replace the 120 volt plug, supplied with the motor, with a UL/CSA Listed plug suitable for 240 volts and the rated current of the

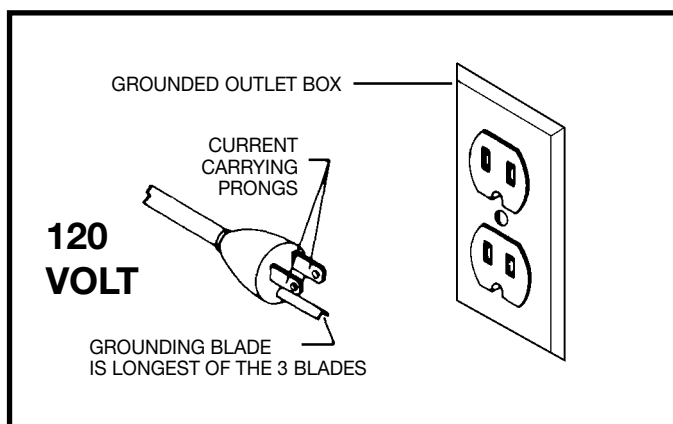

Fig. A

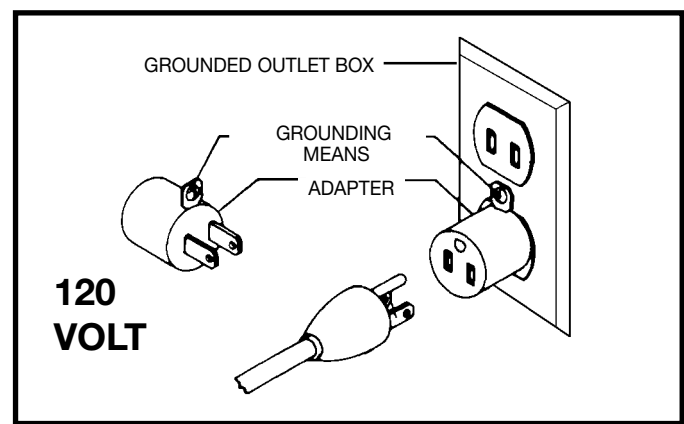

Fig. B

saw as illustrated in Fig. C. Contact your local Authorized Delta Service Center or qualified electrician for proper procedures to install the plug. The saw must comply with all local and national electrical codes after the 240 volt plug is installed.

The saw with a 240 volt plug should only be connected to an outlet having the same configuration as the plug illustrated in Fig. C. No adapter is available or should be used with the 240 Volt plug.

⚠ DANGER IN ALL CASES, MAKE CERTAIN THE RECEPTACLE IN QUESTION IS PROPERLY GROUNDED. IF YOU ARE NOT SURE HAVE A QUALIFIED ELECTRICIAN CHECK THE RECEPTACLE.

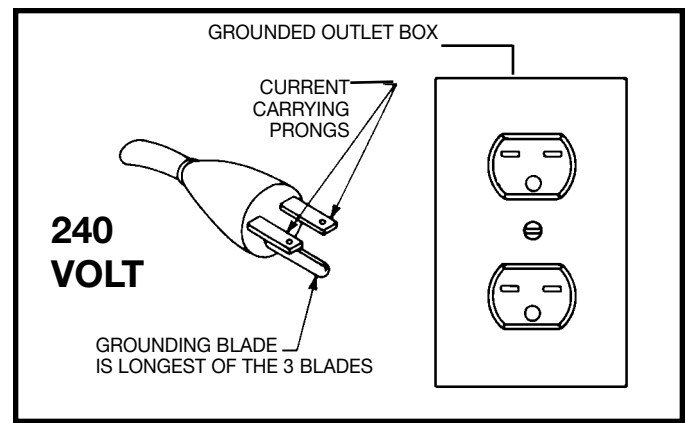

Fig. C

EXTENSION CORDS

CAUTION Use proper extension cords. Make sure your extension cord is in good condition and is a 3-wire extension cord which has a 3-prong grounding type plug and matching receptacle which will accept the machine's plug. When using an extension cord, be sure to use one heavy enough to carry the current of the machine. An undersized cord will cause a drop in line voltage, resulting in loss of power and overheating. Fig. D, shows the correct gauge to use depending on the cord length. If in doubt, use the next heavier gauge. The smaller the gauge number, the heavier the cord.

MINIMUM GAUGE EXTENSION CORD			
RECOMMENDED SIZES FOR USE WITH STATIONARY ELECTRIC MACHINES			
Ampere Rating	Volts	Total Length of Cord in Feet	Gauge of Extension Cord
0-6	120	up to 25	18 AWG
0-6	120	25-50	16 AWG
0-6	120	50-100	16 AWG
0-6	120	100-150	14 AWG
6-10	120	up to 25	18 AWG
6-10	120	25-50	16 AWG
6-10	120	50-100	14 AWG
6-10	120	100-150	12 AWG
10-12	120	up to 25	16 AWG
10-12	120	25-50	16 AWG
10-12	120	50-100	14 AWG
10-12	120	100-150	12 AWG
12-16	120	up to 25	14 AWG
12-16	120	25-50	12 AWG
12-16	120	GREATER THAN 50 FEET NOT RECOMMENDED	

Fig. D

MINIMUM GAUGE EXTENSION CORD			
RECOMMENDED SIZES FOR USE WITH STATIONARY ELECTRIC MACHINES			
Ampere Rating	Volts	Total Length of Cord in Feet	Gauge of Extension Cord
0-6	240	up to 50	18 AWG
0-6	240	50-100	16 AWG
0-6	240	100-200	16 AWG
0-6	240	200-300	14 AWG
6-10	240	up to 50	18 AWG
6-10	240	50-100	16 AWG
6-10	240	100-200	14 AWG
6-10	240	200-300	12 AWG
10-12	240	up to 50	16 AWG
10-12	240	50-100	16 AWG
10-12	240	100-200	14 AWG
10-12	240	200-300	12 AWG
12-16	240	up to 50	14 AWG
12-16	240	50-100	12 AWG
12-16	240	GREATER THAN 100 FEET NOT RECOMMENDED	

Fig. D

OPERATING INSTRUCTIONS

FOREWORD

Delta Model 36-650 is a 10" professional table saw. The Model 36-650 has a powerful 1½ HP induction motor which can handle tough cutting operations. The Model 36-650 comes with a heavy duty fence system with a 30" rip capacity to the right of the blade.

UNPACKING AND CLEANING

Carefully unpack the machine and all loose items from the shipping container(s). Remove the protective coating from all unpainted surfaces. This coating may be removed with a soft cloth moistened with kerosene (do not use acetone, gasoline or lacquer thinner for this purpose). After cleaning, cover the unpainted surfaces with a good quality household floor paste wax.

NOTICE: THE MANUAL COVER PHOTO ILLUSTRATES THE CURRENT PRODUCTION MODEL. ALL OTHER ILLUSTRATIONS ARE REPRESENTATIVE ONLY AND MAY NOT DEPICT THE ACTUAL COLOR, LABELING OR ACCESSORIES AND MAY BE INTENDED TO ILLUSTRATE TECHNIQUE ONLY.

10" PROFESSIONAL TABLE SAW PARTS

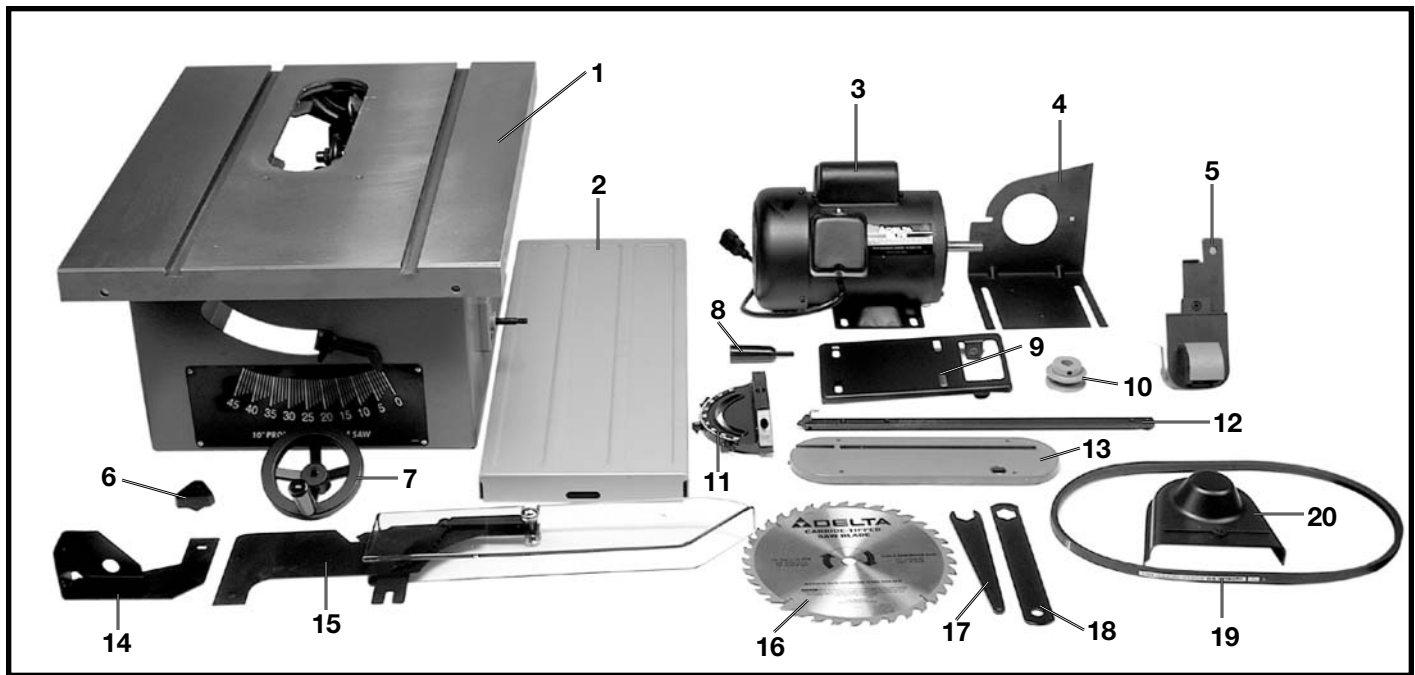

Fig. 2

- | | |
|-----------------------|---------------------------------------|
| 1. Table Saw | 11. Miter Gage Body |
| 2. Extension Wing (2) | 12. Miter Gage Guide Bar |
| 3. Motor | 13. Table Insert |
| 4. Pulley Guard Plate | 14. Splitter Bracket |
| 5. Switch Assembly | 15. Blade Guard and Splitter Assembly |
| 6. Lock Knob (2) | 16. Saw Blade |
| 7. Handwheel (2) | 17. 7/8" Open End Wrench |
| 8. Miter Gage Handle | 18. 7/8" and 1/2" Close End Wrench |
| 9. Motor Plate | 19. Drive Belt |
| 10. Motor Pulley | 20. Belt Guard |

FENCE PARTS

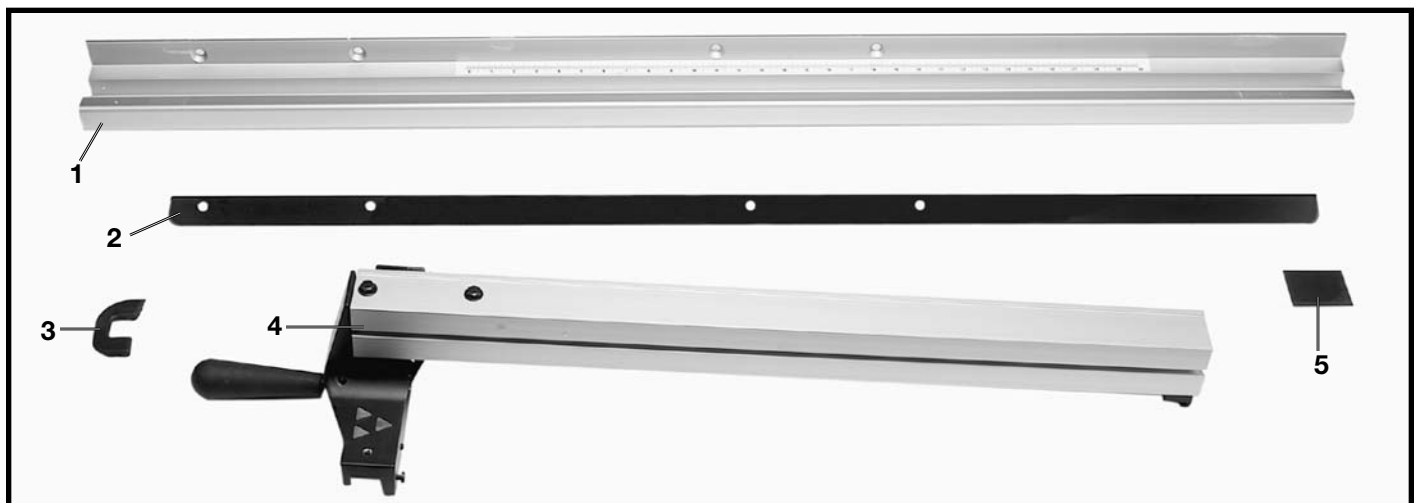

Fig. 3

1. Guide Rail
2. Rear Rail
3. Guide Rail End Cap (2)
4. Fence
5. Fence End Cap

STAND PARTS

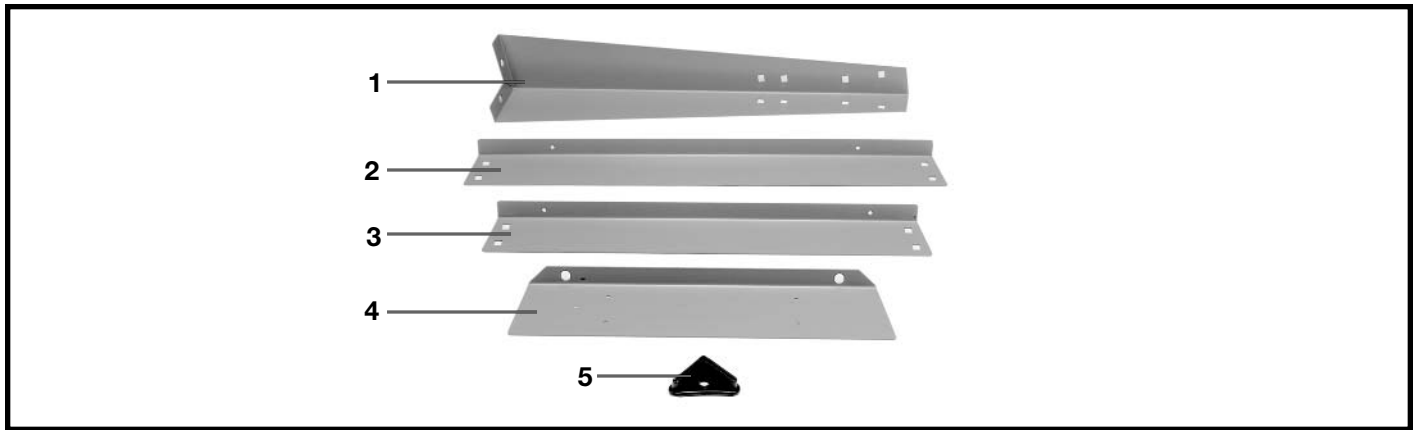

Fig. 4

1. Leg (4)
2. Bracket 24" Long (2)
3. Bracket 21" Long (2)
4. Top Bracket (1)
5. Plastic Foot (4)

HARDWARE

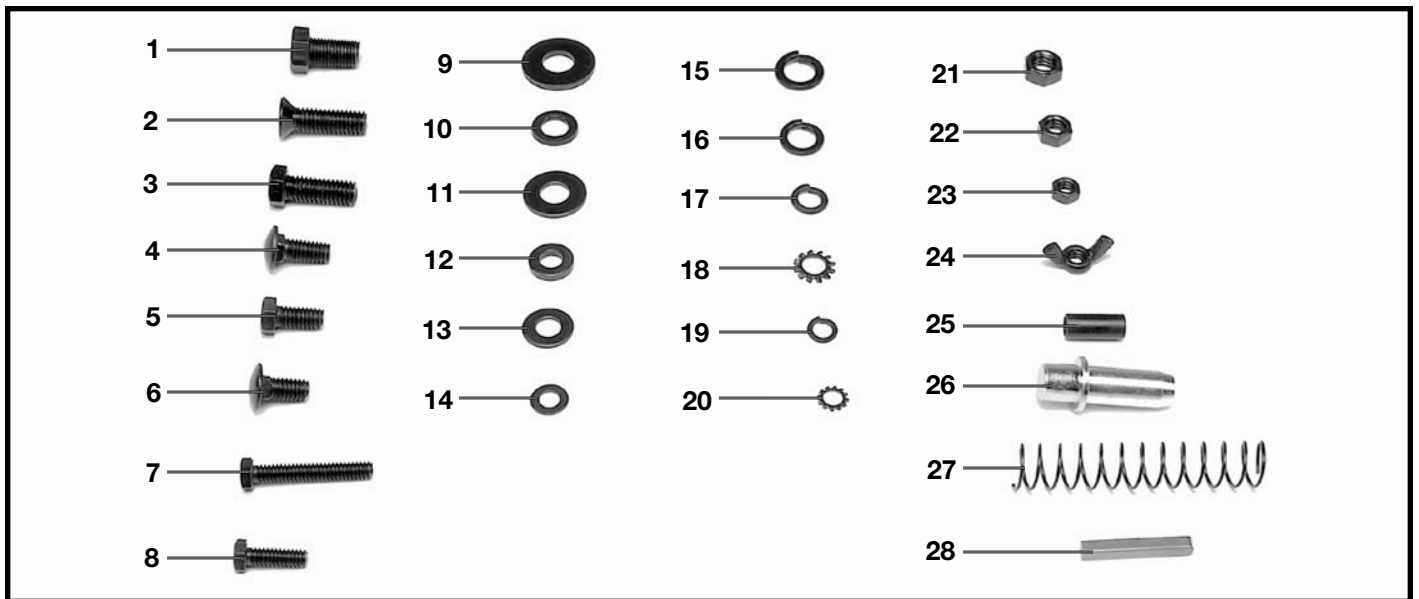

Fig. 5

- | | |
|--|---|
| 1. 7/16-20x3/4" Hex Head Screw (6) | 15. 7/16" Lockwasher (6) |
| 2. 3/8-16x1 1/2" Flat Head Screw (4) | 16. 3/8" Lockwasher (8) |
| 3. 3/8-16x1" Hex Head Screw (4) | 17. 5/16" Lockwasher (24) |
| 4. 5/16-18x3/4" Carriage Head Screw (4) | 18. 5/16" External Tooth Lockwasher (4) |
| 5. 5/16-18x5/8" Hex Head Screw (8) | 19. 1/4" Lockwasher (2) |
| 6. 5/16-18x5/8" Carriage Head Screw (17) | 20. 1/4" External Tooth Lockwasher (2) |
| 7. 1/4-20x1 1/2" Hex Head Screw (1) | 21. 3/8-16 Hex Nut (8) |
| 8. 1/4-20x3/4" Hex Head Screw (2) | 22. 5/16-18 Hex Nut (29) |
| 9. 7/16" Flat Washer (6) | 23. 1/4-20 Hex Nut (1) |
| 10. 10mm Flat Washer (2) | 24. 1/4-20 Wing Nut (1) |
| 11. 3/8" Flat Washer (8) | 25. Spacer (1) |
| 12. 21/64" Flat Washer (1) | 26. Pin (2) |
| 13. 5/16" Flat Washer (37) | 27. Spring (1) |
| 14. 1/4" Flat Washer (3) | 28. Motor Pulley Key (1) |

ASSEMBLY

⚠ WARNING FOR YOUR OWN SAFETY, DO NOT CONNECT THE MACHINE TO THE POWER SOURCE UNTIL THE MACHINE IS COMPLETELY ASSEMBLED AND YOU READ AND UNDERSTAND THE ENTIRE INSTRUCTION MANUAL.

STAND LEGS

1. Assemble the longer bottom bracket (A) Fig. 6, to the inside of two table legs (B) as shown. Align the holes in the longer bottom bracket (A) Fig. 6, with the holes in the table legs (B). Insert a 5/16-18x5/8" carriage head bolt through the hole in the table leg (B) and the hole in the longer bottom bracket (B), place a 5/16" flat washer onto the carriage head bolt, place a 5/16" lockwasher onto the carriage head bolt, thread a 5/16-18 hex nut onto the carriage head bolt. **NOTE:** Only snug-up stand mounting hardware at this time. Repeat this process for the three remaining holes in the larger bottom bracket.
2. Assemble the other stand bracket (A) Fig. 6, to the remaining two table legs (B) in the same manner.
3. Assemble the two shorter stand brackets (D) Fig. 7, to the leg assemblies (B) in the same manner as the longer bottom bracket was assembled.
4. Assemble a rubber foot (E) Fig. 7, to the bottom of each leg as shown.

STAND TO SAW

CAUTION TO PREVENT PERSONAL INJURY OR DAMAGE TO THE MACHINE, WE SUGGEST THAT THE STAND BE MOUNTED TO THE SAW AS FOLLOWS:

1. Place the saw upside down on a sturdy work bench or floor as shown in Fig. 8. **CAUTION** TO PROTECT THE TABLE TOP, PLACE SOMETHING BETWEEN THE TABLE TOP AND THE WORK BENCH OR FLOOR, SUCH AS A PIECE OF CARDBOARD, CARPET ETC. **NOTE:** Make certain the shorter stand brackets (D) Fig. 8, are at the front and rear of the saw as shown.
2. Align the eight holes in the bottom of the saw cabinet with the eight holes in stand legs. Place a 5/16" flat washer onto a 5/16-18x5/8" hex head screw. Insert the hex head screw through the hole in the saw cabinet and the hole in the stand leg. Place a 5/16" flat washer onto the hex head screw, place a 5/16" lockwasher onto the hex head screw, thread a 5/16-18 hex nut onto the hex head screw. **NOTE:** Only snug-up stand mounting hardware at this time. Repeat this process for the five remaining holes in the saw cabinet and the stand legs.
3. Assemble bracket (H) Fig. 9, to the inside of front leg assembly (D) as shown. Align holes in bracket (H) with holes in front leg assembly (D). Place a 5/16" flat washer onto a 5/16-18x5/8" hex head screw. Insert the hex head screw through the hole in the saw cabinet, stand leg, and bracket (H). Place a 5/16" flat washer onto the hex head screw, place a 5/16" lockwasher onto the hex head screw, thread a 5/16-18 hex nut onto the hex head screw. **NOTE:** Only snug-up stand mounting hardware at this time.

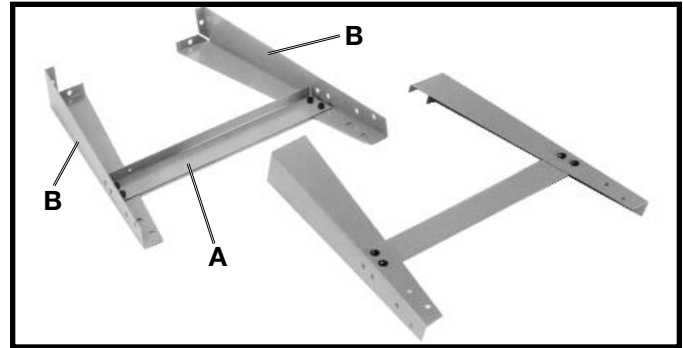

Fig. 6

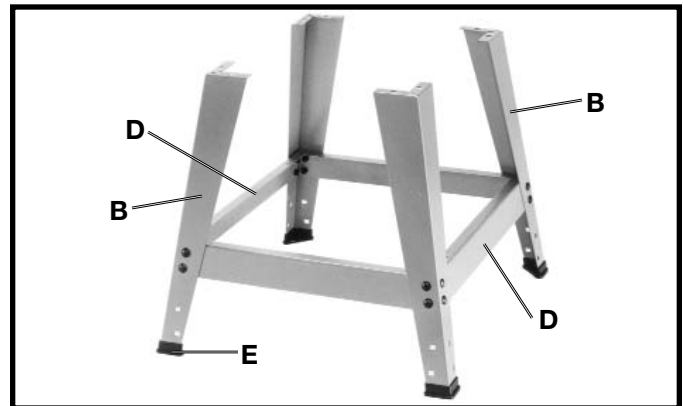

Fig. 7



Fig. 8

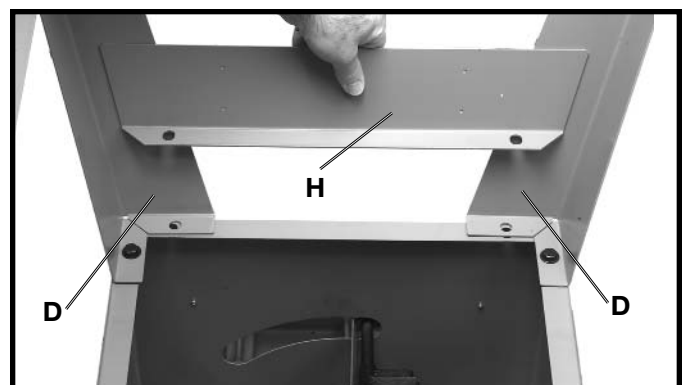

Fig. 9

4. **CAUTION** WITH A MINIMUM OF TWO PEOPLE, CAREFULLY TURN THE SAW AND STAND UPRIGHT AS SHOWN IN FIG. 10. Carefully push down on the top of the saw until the stand legs adapt to the floor surface and firmly tighten all stand mounting hardware.



Fig. 10

BLADE TILTING AND RAISING HANDWHEEL

1. Place blade tilting handwheel (A) Fig. 11, onto shaft (B). Make certain slot (C) in handwheel is engaged with roll pin (D) on the shaft. Place a 10mm flat washer onto shaft (B) Fig. 11. Thread locking knob (E) Fig. 12, onto shaft (B) Fig. 11.

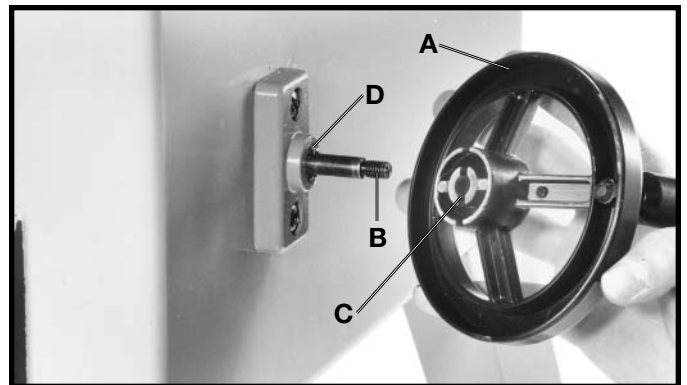

Fig. 11

2. Assemble the blade raising handwheel (A) Fig. 12, to the front of the saw in the same manner.

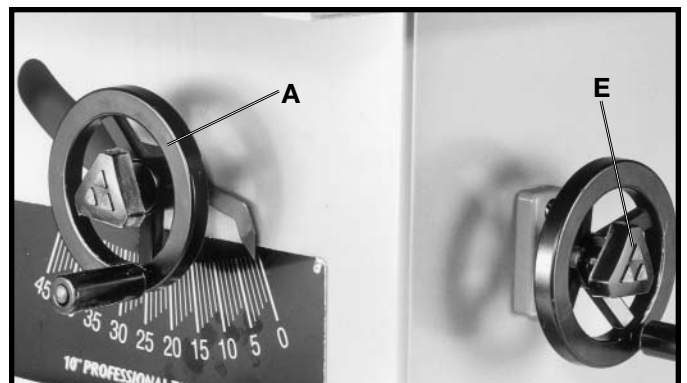

Fig. 12

INSTALLING SWITCH AND MOTOR CORD

1. Insert switch cord (A) Fig. 13, and motor cord (B) of the switch assembly into the opening (C) under saw table as shown, and into the inside of the saw cabinet Fig. 14.

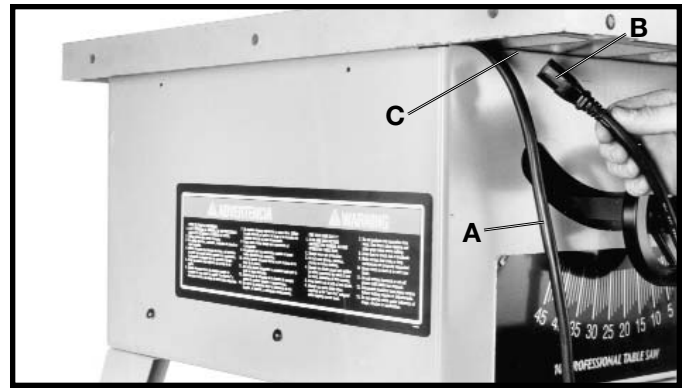

Fig. 13

2. Insert switch cord (A) Fig. 14, and motor cord (B) into clamps (D) and loosely fasten both cords (A) and (B) Fig. 15, to the saw cabinet by turning screws (E) Fig. 14, clockwise. **NOTE:** Cords will be adjusted later. Place switch on top of the saw table at this time.

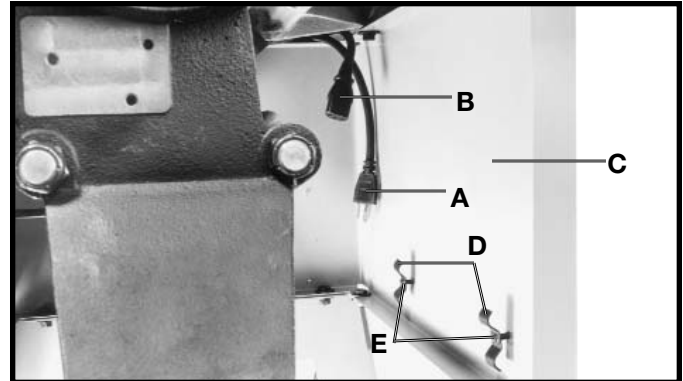

Fig. 14

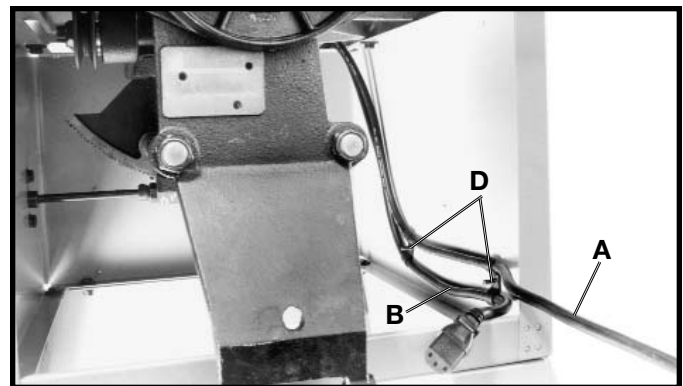

Fig. 15

RECOMMENDED MOTOR FOR YOUR SAW

The motor supplied with this machine has been specially selected to best supply power to your machine and the relative safety of the machine is enhanced by its use. We, therefore, strongly suggest that only this motor be used, as the use of other motors may be detrimental to the performance and safety of the saw.

MOTOR TO MOTOR MOUNTING PLATE

⚠ WARNING DISCONNECT MACHINE FROM POWER SOURCE.

Assemble motor (A) to motor mounting plate (B) as shown in Fig. 16. Align the four mounting holes in the motor with the four holes in the mounting plate. Insert a 5/16-18x3/4" carriage bolt (C), through the hole in motor and then through the hole in the motor mounting plate, place a 5/16" flat washer (D) onto the carriage head bolt, place a 5/16" external tooth washer (E) onto the carriage head bolt, thread a 5/16-18 hex nut (F) onto the carriage head bolt. Repeat this process for the three remaining holes in the motor and the motor mounting plate.

NOTE: Do not completely tighten the hex nuts at this time.

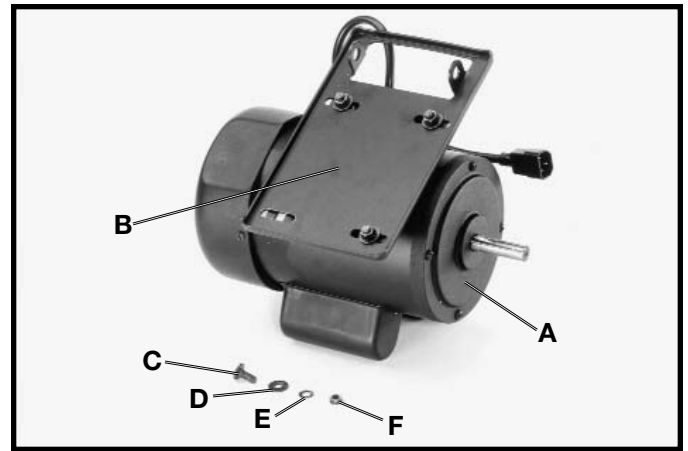

Fig. 16

MOTOR AND MOTOR MOUNTING PLATE TO SAW

⚠ WARNING DISCONNECT MACHINE FROM POWER SOURCE.

1. Insert a pin (X) Fig. 17, into the holes in each side of bracket (B). **NOTE: INSERT THE TAPERED END OF PIN (X) FIG. 17, THROUGH THE INSIDE HOLE OF BRACKET (B).**

2. Assemble spring (Y) Fig. 17, onto the non tapered end of each pin (X) as shown.

3. Position motor and motor mounting plate (A) Fig. 17, below bracket (B) to allow bracket arm to slide through large opening in motor mounting plate (A).

4. Depress pins (X) Fig. 18, on both sides of bracket (B) and rotate motor mounting plate (A) until pins (X) are engaged in holes (D) Fig. 17, of motor mounting plate (A).

5. Fig. 19, illustrates the motor and motor mounting plate assembled to the rear of the saw.

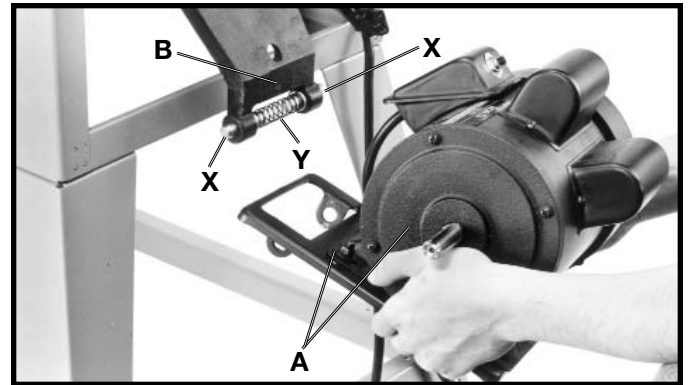

Fig. 17

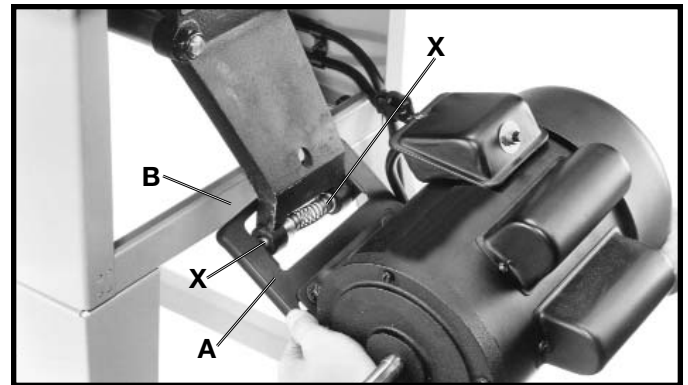

Fig. 18

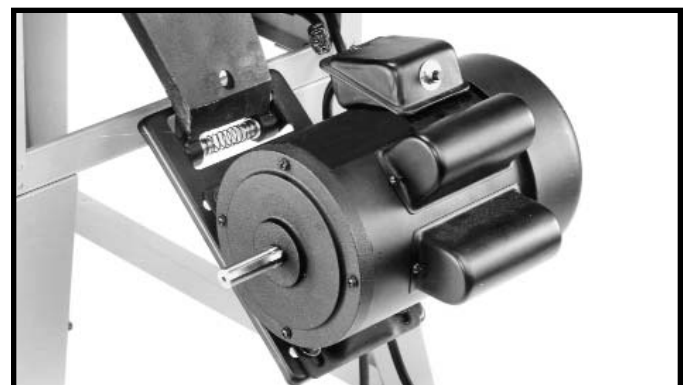

Fig. 19

MOTOR PULLEY, PULLEY GUARD, AND DRIVE BELT

⚠ WARNING DISCONNECT MACHINE FROM POWER SOURCE.

1. Remove the motor shaft key that is taped to the motor.
2. Insert key (A) Fig. 20, in the keyway on the motor shaft. Assemble motor pulley (B) on motor shaft as shown, with the hub of the pulley out. Tighten set screw (C) against key (A) in motor shaft.
3. Slide the belt and pulley guard bracket (G) Fig. 22, between the motor plate (A) and motor mounting plate (C), as shown.
4. Place a 1/4" external tooth lockwasher onto a 1/4-20x1-1/2" hex head screw. Insert the screw (D) Fig. 22, through the hole in the belt and pulley guard bracket (G) as shown in Fig. 22.

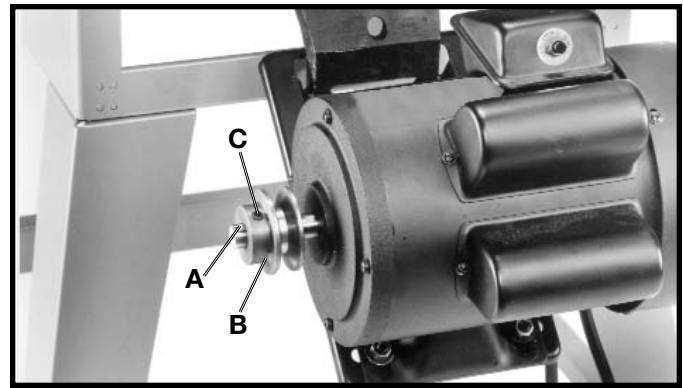

Fig. 20

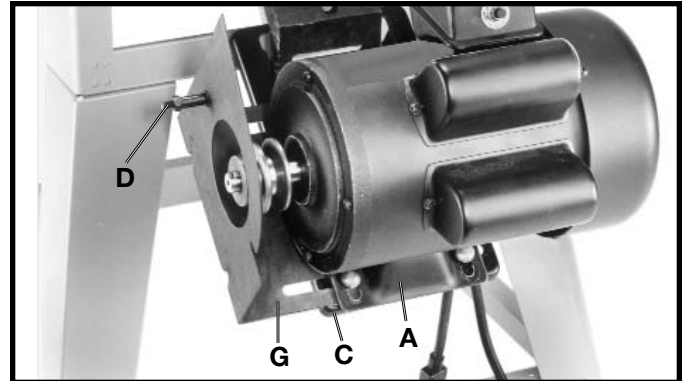

Fig. 22

5. Position belt and pulley guard bracket (G) Fig. 23, so the motor pulley (B) is centered and through the hole in the belt and pulley guard bracket (G), as shown in Fig. 24. Tighten the four hex nuts that fasten the motor to the motor mounting plate.
6. Using a straight edge, align the motor pulley with the arbor pulley. If necessary, adjust the motor pulley (B) Fig. 23, in or out on the motor shaft.
7. Lift up on the motor and assemble the drive belt (H) Fig. 24, to the arbor pulley and motor pulley (B). The weight of the motor will provide the correct belt tension.

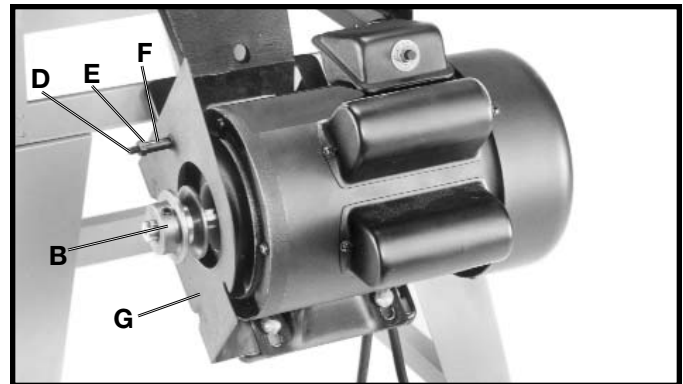

Fig. 23

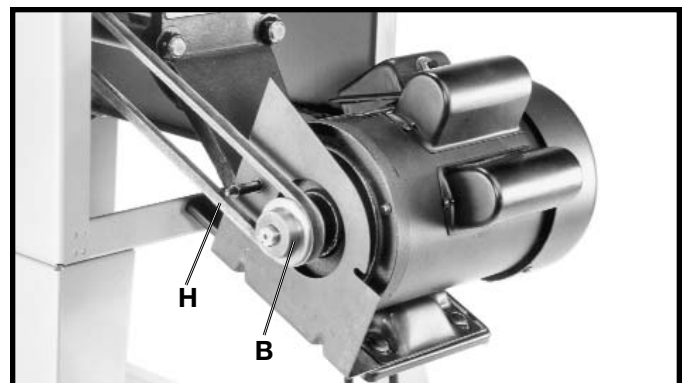

Fig. 24

8. **⚠ WARNING** IMMEDIATELY AFTER ASSEMBLING THE BELT, RAISE THE SAW BLADE TO ITS MAXIMUM HEIGHT AND TILT THE SAW BLADE TO 45 DEGREES. USING A STRAIGHT EDGE (L) FIG. 25, CHECK TO SEE IF THE MOTOR END (J) FIG. 25, IS BELOW THE TOP OF THE TABLE SURFACE (K). IF THE MOTOR END (J) IS ABOVE THE TOP OF THE TABLE SURFACE, THE MOTOR MUST BE MOVED TO THE LEFT UNTIL YOU ARE CERTAIN THE TOP (J) OF THE MOTOR IS BELOW THE TOP OF THE TABLE SURFACE. THEN RE-ALIGN THE MOTOR PULLEY TO THE ARBOR PULLEY.

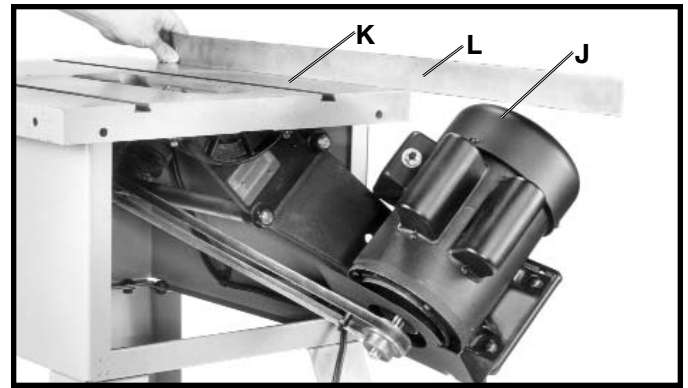

Fig. 25

9. Place a 1/4" flat washer onto the 1/4-20x1-1/2" hex head screw (D) Fig. 23. Place the spacer (F) Fig. 23, onto the 1/4-20x1-1/2" hex head screw (D) Fig. 23, and thread a 1/4-20 hex nut (E) Fig. 23, onto the hex head screw.

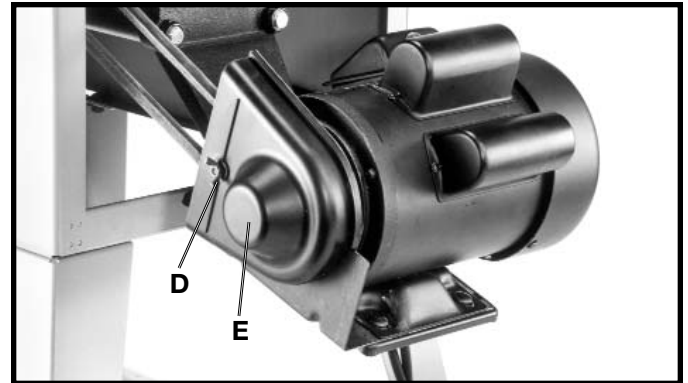

Fig. 26

10. Align the hole in the outer cover (D) Fig. 26, with the 1/4-20x1-1/2" hex head screw (D) Fig. 23. Place the outer cover (E) Fig. 23, onto the hex head screw. Place a 1/4" external tooth lockwasher onto the hex head screw, thread a 1/4-20 wing nut onto the hex head screw, and tighten securely. **CAUTION** Make certain the outer cover does not interfere with the drive belt and the motor pulley.

CONNECTING MOTOR CORD TO SWITCH ASSEMBLY

⚠ WARNING DISCONNECT MACHINE FROM POWER SOURCE.

1. Insert the pronged motor plug (A) Fig. 27, into the female receptacle (B) of switch-to-motor cord (C).



Fig. 27

2. Fig. 28, illustrates the motor cord connected to the switch assembly.



Fig. 28

BLADE GUARD AND SPLITTER ASSEMBLY

⚠ WARNING DISCONNECT MACHINE FROM POWER SOURCE.

1. Fasten the rear splitter mounting bracket (A) Fig. 29, to the rear trunnion. Align the two holes in the rear splitter mounting bracket with the two holes in the trunnion. Place a 1/4" lock washer onto a 1/4-20x3/4" hex head screw, place a 1/4" flat washer onto the hex head screw, insert the hex head screw through the hole in the rear splitter mounting bracket and thread the hex head screw into the rear trunnion. Repeat this process for the remaining hole. **Do not completely tighten the two screws (B) at this time.**

2. Raise saw arbor to its highest position.

3. Remove screw and large washer (C) Fig. 30, from the inside splitter mounting bracket.

4. Using a straight edge, check to see if the top and bottom of the inside splitter bracket (D) Fig. 31, is aligned with the inner arbor flange (E), as shown.

5. If alignment is necessary, loosen the two screws (F) Fig. 32, align bracket (D) with the arbor flange and tighten screws (F).

6. Loosely assemble large washer and screw (C) Fig. 32, to the inside splitter bracket. This screw and washer was removed in **STEP 3**.

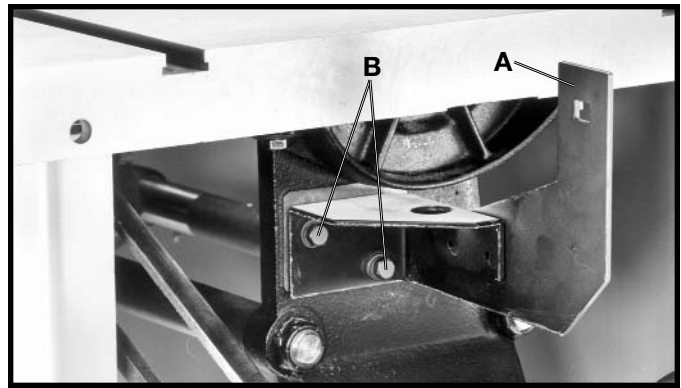

Fig. 29



Fig. 30

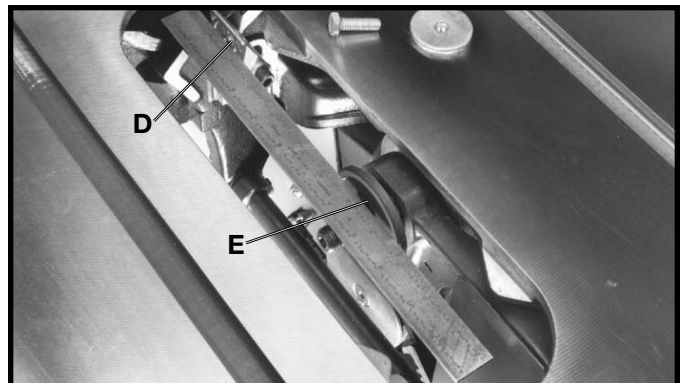

Fig. 31

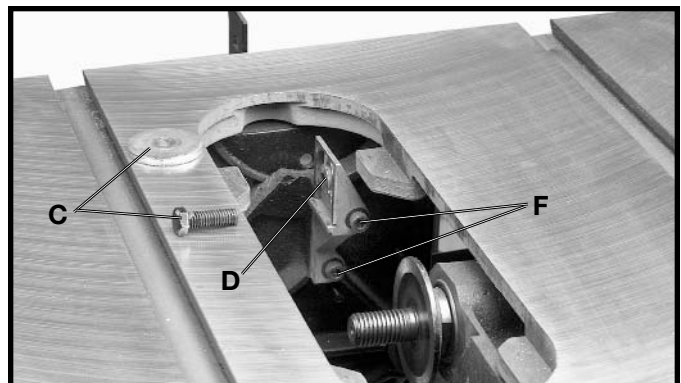

Fig. 32

7. Assemble the blade guard and splitter assembly (G) Fig. 33, between the large washer (C) and the splitter bracket and tighten screw (H) with wrench supplied.

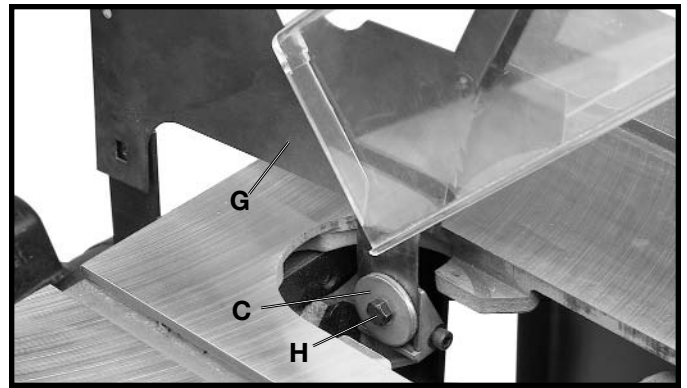

Fig. 33

8. Fasten the rear of the blade guard and splitter bracket assembly (G) Fig. 34, to the rear splitter mounting bracket. Align the hole in the blade guard and splitter bracket with the hole in the rear splitter mounting bracket. Insert a 5/16-18x5/8" carriage head screw through the hole (J) in the blade guard and splitter assembly and through the hole in the rear splitter mounting bracket, place a 5/16" flat washer onto the carriage head screw, thread a 5/16-18 hex nut onto the carriage head screw and tighten securely. **IMPORTANT:** The splitter (G) Fig. 34, has a notch (L) cut in the top edge as shown. This feature will enable the blade guard to stay in the raised position to make blade changing easier. Raise the front of blade guard (M) Fig. 35, until the rear edge of the blade guard slips into notch (L) of splitter (G); the blade guard will stay in this position.

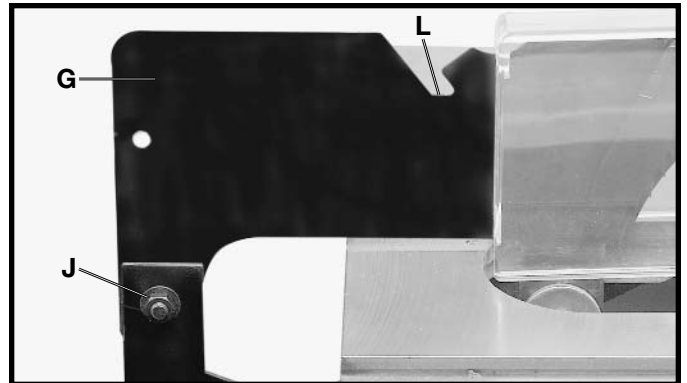

Fig. 34

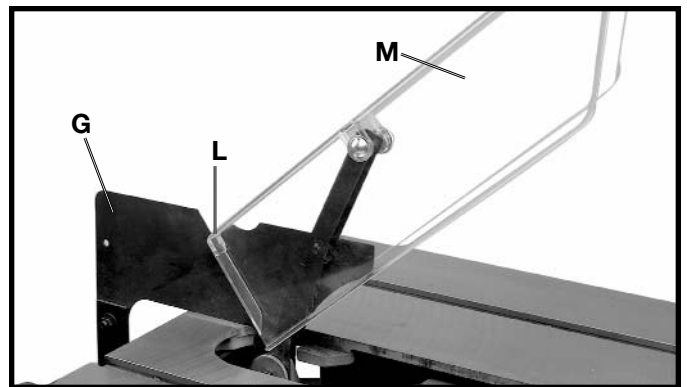

Fig. 35

9. With the blade guard (L) Fig. 36, in the raised position, assemble the saw blade (K) on the saw arbor with two arbor wrenches supplied.

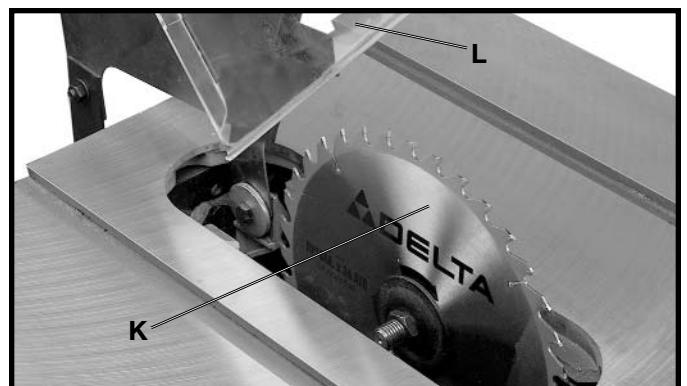

Fig. 36

10. Using a straight edge, check to see if the saw blade is aligned with the rear of the splitter (G), as shown in Fig. 37. If alignment is necessary, loosen the screws (A) Fig. 37, align splitter (G) with the saw blade, and tighten two screws (A).

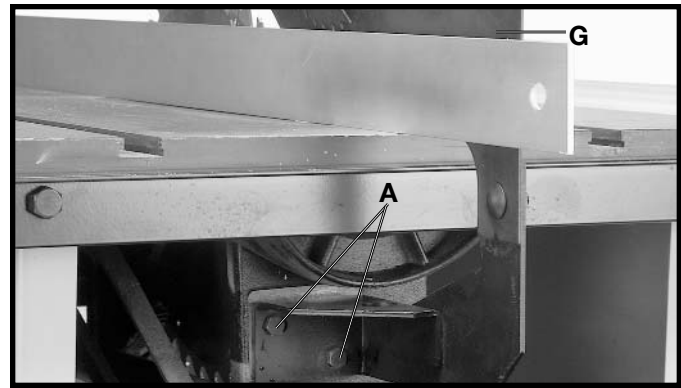

Fig. 37

11. Lower saw blade and install table insert (P) Fig. 38, in the saw table as shown. **CAUTION THE TABLE INSERT SHOULD BE LEVEL WITH THE TABLE SURFACE. IF AN ADJUSTMENT IS NECESSARY, SEE THE SECTION "ADJUSTING TABLE INSERT".**

CAUTION When installing the table insert, always make certain to hold on to the blade guard (L). The insert will automatically release the holding action on the splitter and lower the blade guard when it is installed in the table opening.



Fig. 38

EXTENSION WINGS

1. Assemble extension wing (A) Fig. 39, to the saw table. Align the three holes in the extension wing with the three holes in the side of the saw table. Place a 7/16" lockwasher (C) Fig. 39, onto a 7/16-20x3/4" hex head screw (B), place a 7/16" flat washer (D) onto the hex head screw. Insert the screw through the hole in the extension wing and thread the screw into the tapped hole in the side of the saw table. Repeat this process for the two remaining holes in the extension wing and the saw table.

2. With a straight edge (E) Fig. 39, make certain the extension wing (A) is level with the saw table before tightening three screws (B).

3. Assemble the other extension wing to the opposite end of the saw table in the same manner.

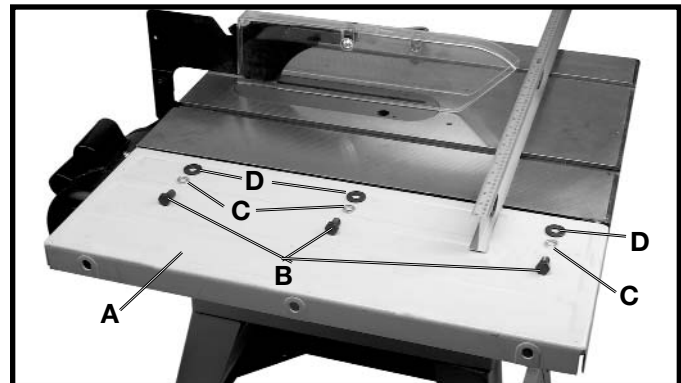

Fig. 39

GUIDE RAILS AND SWITCH ASSEMBLY

1. Loosely assemble front guide rail (A) Fig. 40, to the front of the saw table. Align the two holes (B) and (C) with the two holes in the saw table. Insert a 3/8-16x1-1/2" flat head screw (F) Fig. 40, through holes (B) and (C) in the front guide rail (A) and the holes in the front of the saw table. Place hole in switch bracket (E) Fig. 40, on screw (B) located behind the inner lip of the saw table. Place a 3/8" flat washer (G) and a 3/8 lockwasher (H), onto the flat head screw (F). Thread a 3/8-16 hex nut (J), onto the flat head screw (F). Repeat this process for the remaining hole (C) in the guide rail and the saw table.

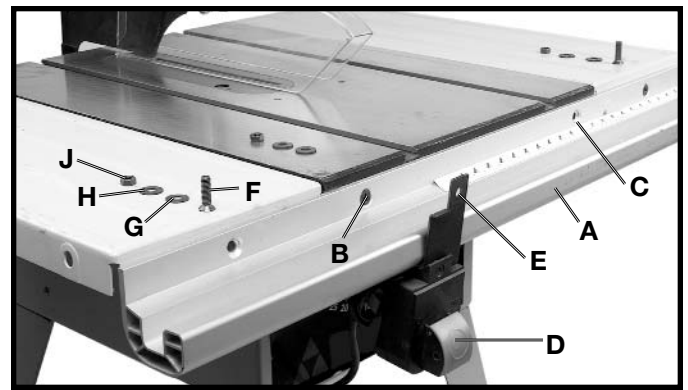

Fig. 40

2. Loosely fasten guide rail (A) Fig. 41, to the left and right extension wings. Align the hole (B) Fig. 41, in the left side of the guide rail with the hole on the left extension wing. Insert a 3/8-16x1-1/2" flat head screw through the hole (B) in the front guide rail (A) and the hole in the front of the left extension wing. Place a 3/8" flat washer and a 3/8 lockwasher onto the flat head screw. Thread a 3/8-16 hex nut onto the flat head screw. Repeat this process for the remaining hole in the guide rail and the right extension wing.

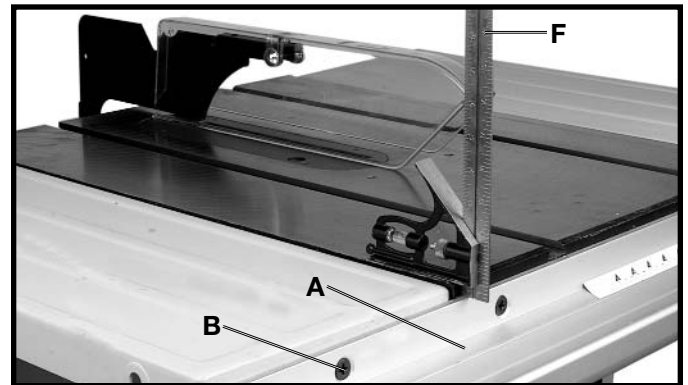

Fig. 41

3. Before tightening the hardware holding the guide rail to the saw table, proceed as follows: Beginning at the two sides of the saw table and using an adjustable square (F) Fig. 41, or a ruler, check to make certain the guide rail (A) is parallel with the saw table and extension wings. Tighten all guide rail mounting hardware.

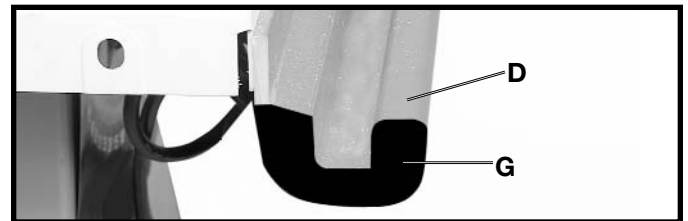

Fig. 42

4. Insert end cap (G) Fig. 42, onto each end of the guide rail (D) as shown. Using a block of wood and hammer, gently tap end caps until they are completely seated into each end of the guide rail. **NOTE:** Do not use a hammer directly against the end caps, this could cause damage to the aluminum rail.

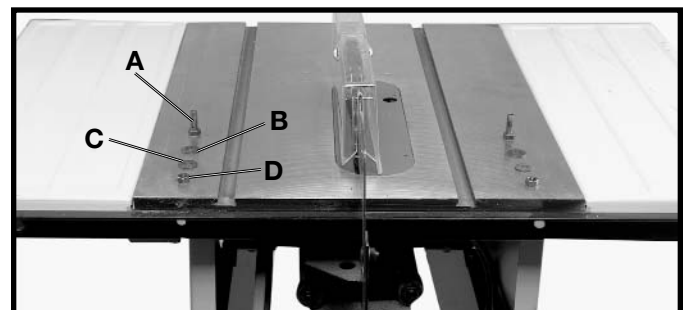

Fig. 43

5. Align holes in saw table and extension wings with four holes in rear guide rail (J) Fig. 43. **NOTE:** Flat edge of rear guide rail (J) will face upward. Insert a 3/8-16x1" hex head screw (A) Fig. 43, through hole in rear guide rail and hole in saw table. Place a 3/8" flat washer (B) Fig. 43, and a 3/8" lock washer (C), onto the hex head screw. Thread a 3/8-16 hex nut (D), onto the hex head screw. Repeat this process for the three remaining holes in the rear guide rail and the saw table and extension wings.

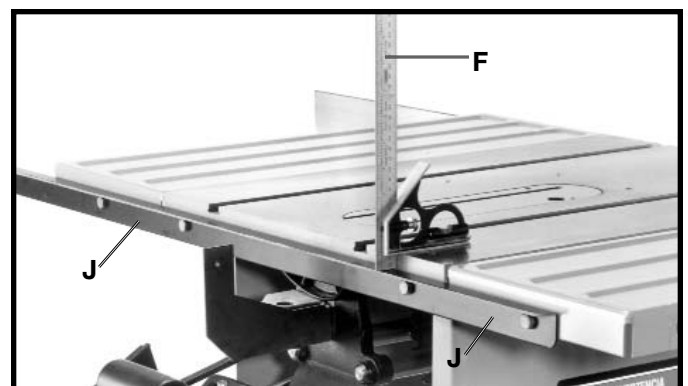

Fig. 44

6. Before tightening mounting hardware, using an adjustable square (F) Fig. 44, or a ruler, check to make certain the rear guide rail (J) is parallel with the saw table and extension tables.

RIP FENCE TO GUIDE RAILS

1. Insert end cap (A) Fig. 45, into back of rip fence (B).
2. With the fence handle (A) Fig. 46, in the raised position, place the rip fence (B) onto the rear guide rail (C) so the hooked end (D) Fig. 45, fits over the top ledge of the guide rail as shown.

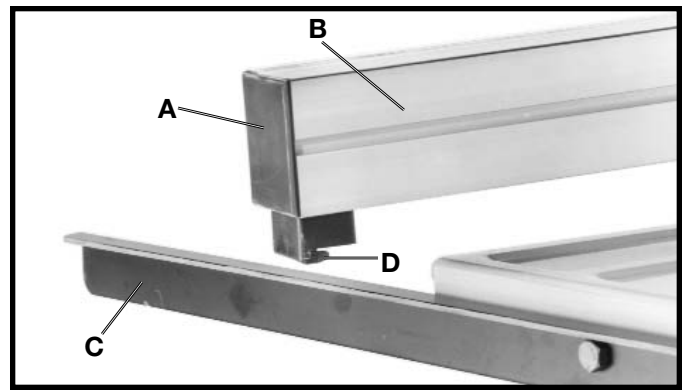

Fig. 45

3. Lower the front of rip fence (B) Fig. 46, onto the front guide rail (L).
4. Lock the rip fence (B) Fig. 46, on the guide rails by pushing down handle (A).

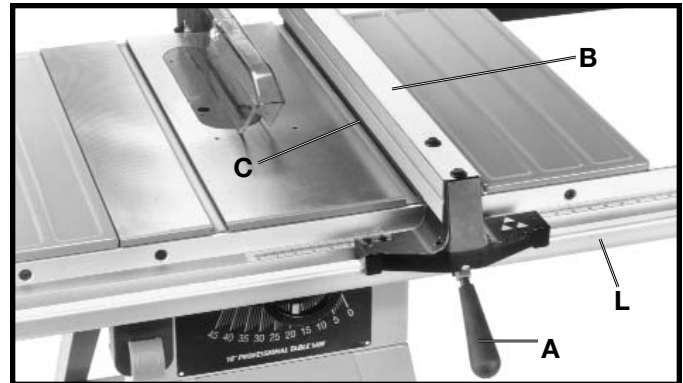

Fig. 46

5. Slide rip fence (B) Fig. 46, against one edge of the miter gage slot (C) as shown. Clamp the fence onto the guide rail by pushing down on lock handle (A). The edge of the fence (B) Fig. 46, should line up so it is parallel with the edge of the miter gage slot. If an adjustment is necessary, tighten or loosen either of two screws (D) Fig. 47, as necessary until rip fence (B) Fig. 46, lines up with the miter gage slot. **NOTE:** Cursor has been removed for clarity.

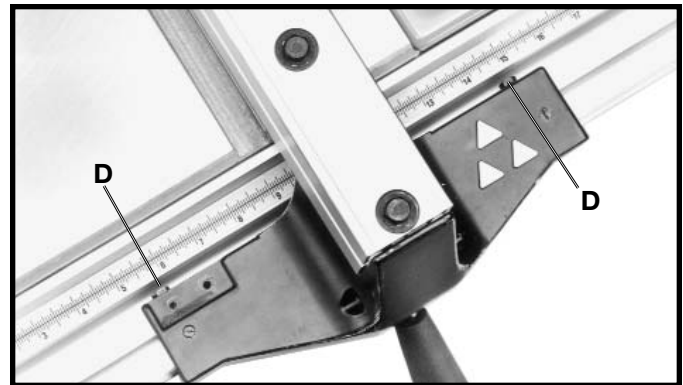

Fig. 47

6. Once the rip fence is aligned with the miter gage slot, raise the saw blade (E) Fig. 48, to its highest position, as shown. Slide rip fence (B) against the saw blade (E) and lock the fence in that position by pushing down on handle (A).

7. The cursor witness line (F) Fig. 49, should line up with the "zero" mark on scale (G). If the witness line does not line up with the "zero" line on the scale, loosen two screws (H) and adjust cursor (K).

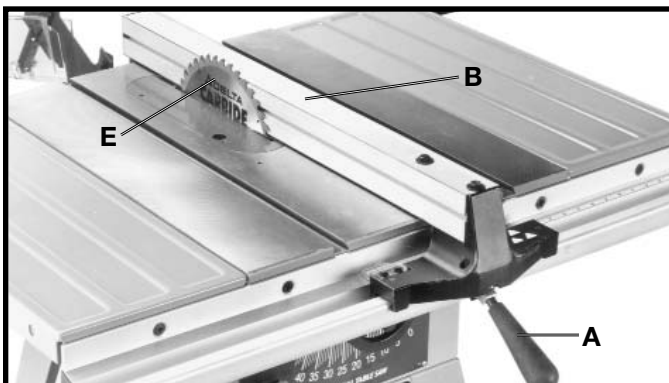

Fig. 48

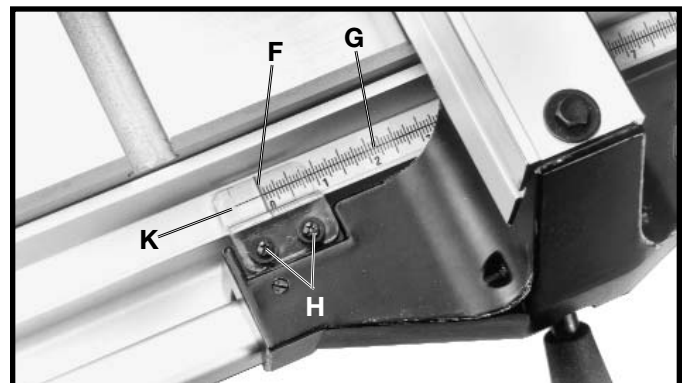

Fig. 49

OPERATING CONTROLS AND ADJUSTMENTS

STARTING AND STOPPING SAW

1. The on/off switch is located underneath the switch shield (A) Fig. 54. To turn the saw "ON," move switch trigger (B) to the up position.

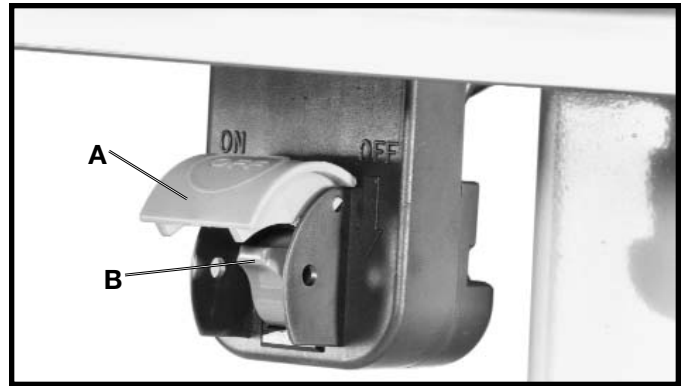

Fig. 54

2. To turn the saw "OFF," push down on switch shield (A) Fig. 55.

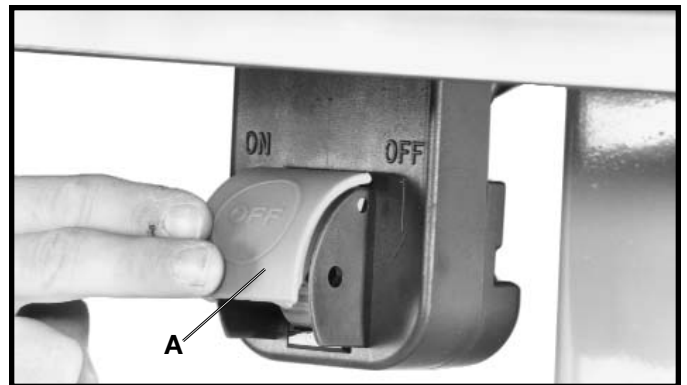

Fig. 55

LOCKING SWITCH IN THE "OFF" POSITION

IMPORTANT: When the tool is not in use, the switch (B) Fig.56, should be locked in the OFF position using a padlock (C), with a 3/16" diameter shackle to prevent unauthorized use.

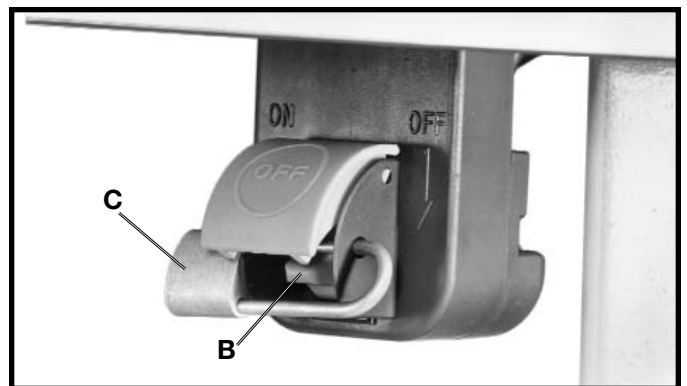

Fig. 56

RAISING AND LOWERING THE BLADE

To raise the saw blade, loosen lock knob (A) Fig. 58, and turn the blade raising handwheel (B) clockwise. When the blade is at the desired height, tighten lock knob (A).

To lower the blade, loosen lock knob (A) Fig. 58, and turn the handwheel (B) counterclockwise. **NOTE:** One full turn of the handwheel will change blade height approximately 1/4".

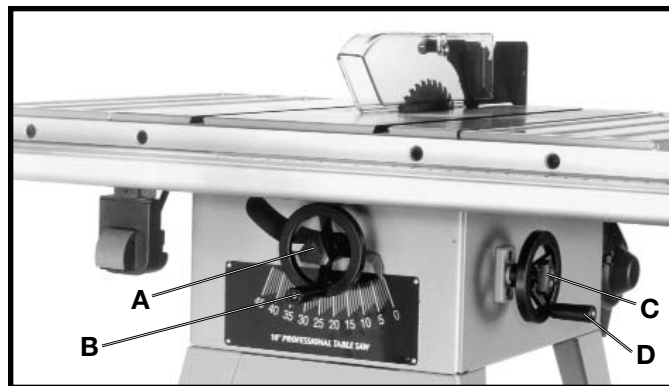

Fig. 58

TILTING THE BLADE

To tilt the saw blade for bevel cutting, loosen lock knob (C) Fig. 58, and turn the tilting handwheel (D). When the desired blade angle is obtained, tighten lock knob (C).

ADJUSTING 90 DEGREE AND 45 DEGREE POSITIVE STOPS

Your saw is equipped with positive stops that will quickly and accurately position the saw blade at 90 degrees and 45 degrees to the table. To check and adjust the positive stops, proceed as follows:

⚠ WARNING DISCONNECT MACHINE FROM POWER SOURCE.

1. Raise the saw blade to its highest position.
2. Set the blade at 90 degrees to the table by turning the blade tilting handwheel counterclockwise as far as it will go.
3. Using a combination square (A) Fig. 59, check to see if the blade is at 90 degrees to the table surface as shown.
4. If the blade is not at 90 degrees to the table, loosen set screw (B) Fig. 59 with supplied wrench (C), and turn the blade tilting handwheel until you are certain the blade is at 90 degrees to the table. Turn set screw (B) clockwise until it bottoms.
5. Adjust the pointer (D) Fig. 60, to point to the zero degree mark on the scale by loosening screw (E), adjusting pointer (D), and tightening screw (E).
6. Turn the blade tilting handwheel clockwise as far as it will go and using a combination square, check to see if the blade is at 45 degrees to the table.
7. If the blade is not at 45 degrees to the table, loosen set screw (F) Fig. 59, and turn blade tilting handwheel until you are certain the blade is 45 degrees to the table. Turn set screw (F) clockwise until it bottoms.

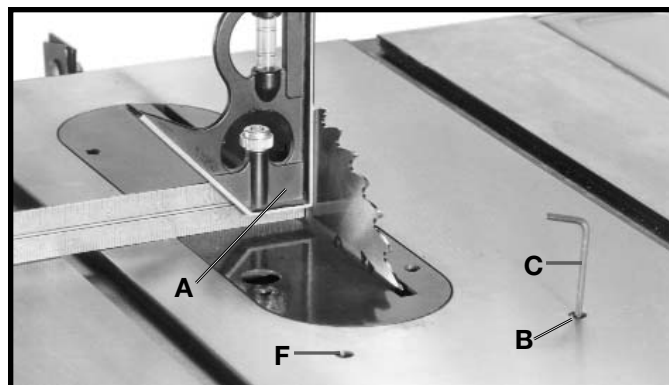

Fig. 59

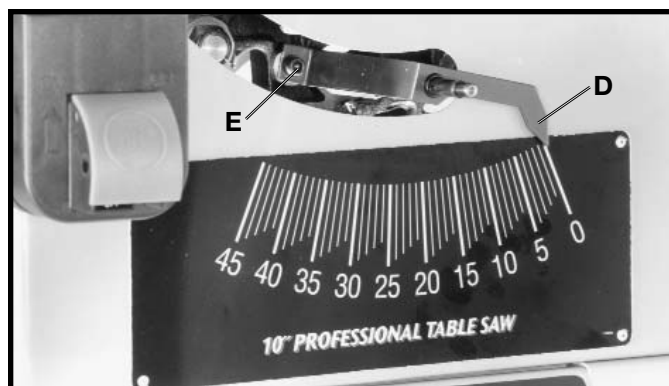

Fig. 60

BACKLASH ADJUSTMENTS FOR BLADE RAISING AND BLADE TILTING MECHANISMS

If any play is detected in the blade raising or blade tilting mechanisms, the following adjustments should be made.

⚠ WARNING DISCONNECT MACHINE FROM POWER SOURCE.

1. **NOTE:** The machine has been turned upside down and the blade removed for clarity and safety.
2. **Adjusting blade raising mechanism** - Loosen locknut (A) Fig. 61, and turn eccentric sleeve (B) until all play is removed in mechanism, then tighten locknut (A).
3. **Adjusting blade tilting mechanism** - Loosen locknut (C) Fig. 61, and turn eccentric (D) until all play is removed in mechanism, then tighten locknut (C).

RIP FENCE OPERATION AND ADJUSTMENTS

The rip fence can be used on either side of the saw blade. The most common location is on the right side and is guided by means of guide rails which are fastened to the front and rear of the table.

1. To move the rip fence, raise the lock handle (A) Fig. 62, as far as it will go and move the fence to the desired position on the table. When the lock handle (A) Fig. 62, is pushed down, clamping action on the rip fence (B) should be adequate. However, if the clamping action is too loose or too tight, an adjustment can be made by equally tightening or loosening two screws (C) as necessary. **NOTE:** It will be necessary to remove the cursor (D) Fig. 64, to make this adjustment

⚠ WARNING THE BLADE FLANGE IS SET PARALLEL TO THE MITER GAGE SLOT AT THE FACTORY AND THE RIP FENCE MUST BE PROPERLY ALIGNED TO THE MITER GAGE SLOT IN ORDER TO PREVENT "KICKBACK" WHEN RIPPING.

2. Position the fence (B) Fig. 62, along one edge of the miter gage slot (F) as shown and lock the fence in that position. The edge of the fence (B) Fig. 62, should be parallel to the miter gage slot (F). If an adjustment is necessary, proceed as follows:
3. Tighten or loosen either of two screws (C) Fig. 62, as necessary, until the fence (B) is parallel to the miter gage slot. **NOTE:** It will be necessary to remove the cursor (D) Fig. 64, to make this adjustment. Readjust the clamping action on the fence; if necessary, refer to **STEP 1**. Re-assemble the cursor.

⚠ CAUTION THE RIP FENCE MUST BE PERPENDICULAR TO AND LEVEL WITH THE SAW TABLE.

4. Using a square (G) Fig. 63, check to see if the rip fence (B) is perpendicular to the saw table and that the rip fence body is level with the saw table. If an adjustment is necessary, tighten or loosen either of two screws (K), until the fence is perpendicular and level with the saw table.

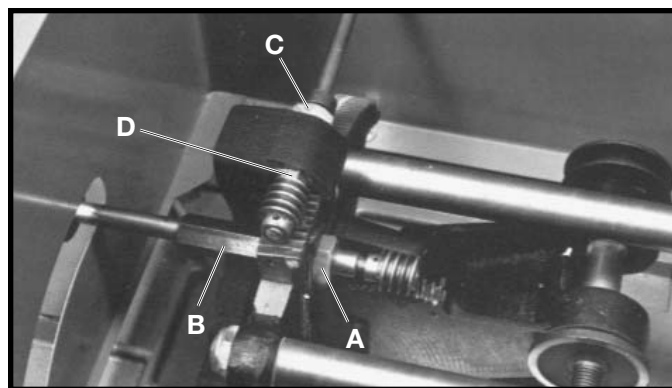

Fig. 61

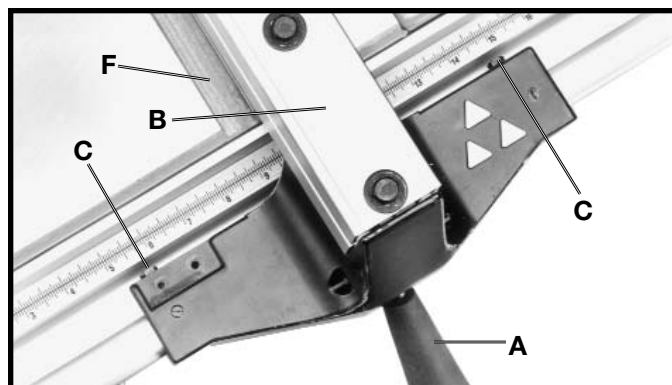

Fig. 62

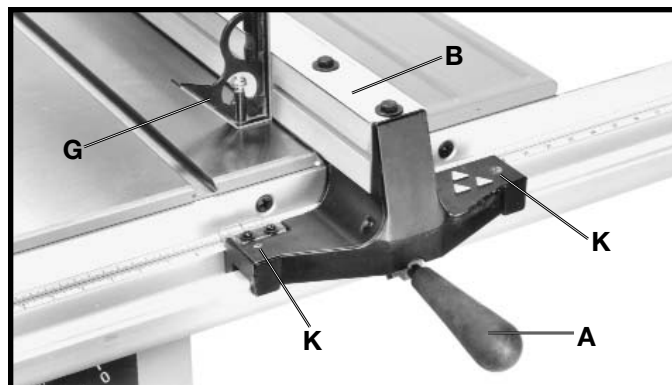

Fig. 63

5. Depending on the type of saw blade being used, the cursor (D) Fig. 64, may need adjustment to compensate for the blade thickness. To adjust the cursor, make a test cut on a piece of lumber and measure the finished cut, or you can place the rip fence against the blade as shown earlier in the manual. If a minor adjustment is necessary, loosen two screws (E) Fig. 64, and move the cursor (D) as necessary.

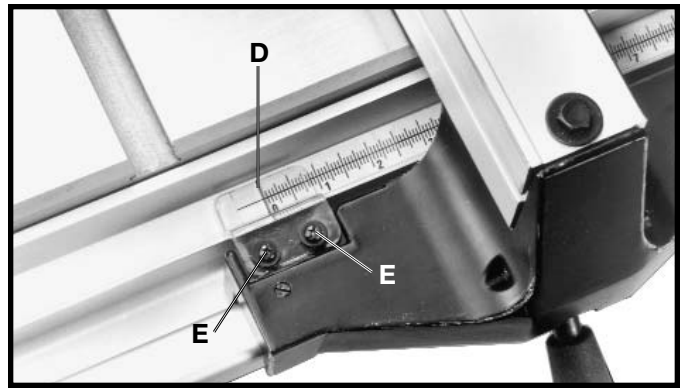

Fig. 64

MITER GAGE OPERATION AND ADJUSTMENT

Insert the miter gage bar (B) Fig. 65, into the miter gage slot. Insert the metal stud on the bottom of the miter gage body (C) Fig. 65, into the non tapped hole in the miter gage bar. Place a $2\frac{1}{64}$ " flat washer (D) Fig. 65, onto the miter gage handle (A). Insert the threaded end of the miter gage handle (A) Fig. 65 through the slot (E) on the miter gage body and thread the handle into the miter gage bar (B).

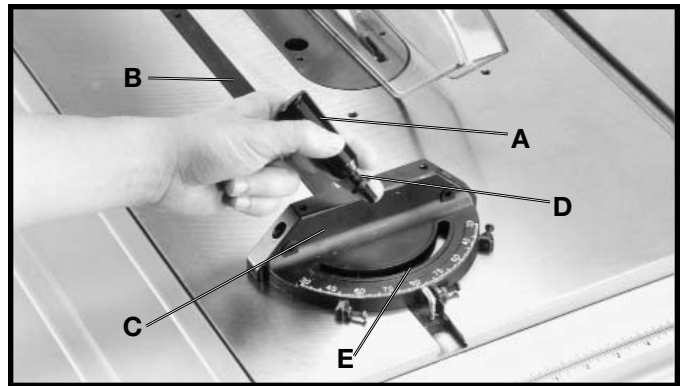

Fig. 65

The miter gage is equipped with adjustable index stops at 90 degrees and 45 degrees right and left. The index stops can be adjusted by tightening or loosening the three adjusting screws (B) Fig. 66.

To rotate the miter gage, loosen lock knob (A) Fig. 66, and move the body of the miter gage (C) to the desired angle.

The miter gage body will stop at 90 degrees and 45 degrees both right and left. To rotate the miter gage body past these points, lift the stop link (D) Fig. 66, up and out of the way.

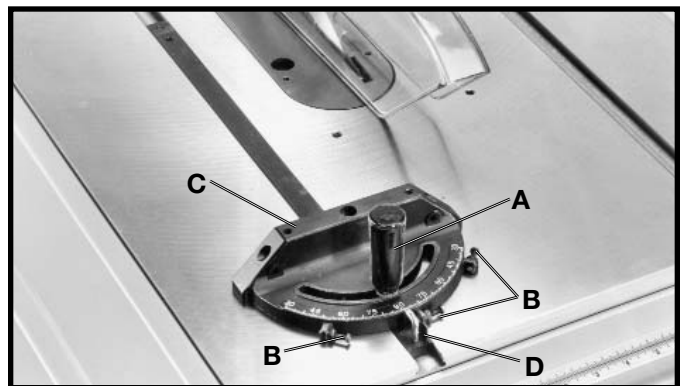

Fig. 66

The miter gage is equipped with a special washer (E) Fig. 67, and flat head screw (F), which are to be assembled to the end of the miter gage bar.

The head of the miter gage pivots on a special tapered screw (G) that fastens the head to the miter gage bar. If the miter gage head does not pivot freely, or pivots too freely, it can be adjusted by loosening set screw (H) Fig. 67, and turning the screw (G), in or out. Be certain to tighten screw (H) after adjustment is made.

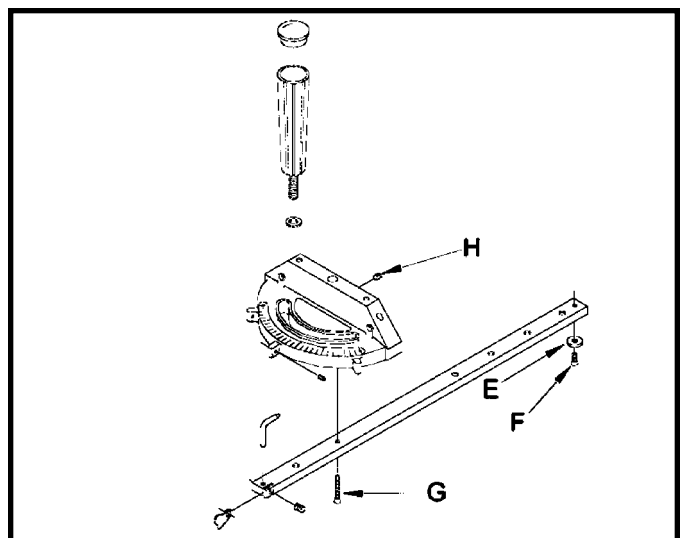

Fig. 67

ADJUSTING TABLE INSERT

⚠ WARNING DISCONNECT MACHINE FROM POWER SOURCE.

Place a straight edge across the table at both ends of the table insert as shown in Fig. 68. The table insert (A) should always be level with the table. If an adjustment is necessary, turn the adjusting screws (B), as needed. Four adjusting screws (B) are supplied in the table insert. The table insert is equipped with a finger hole (C) for easy removal.

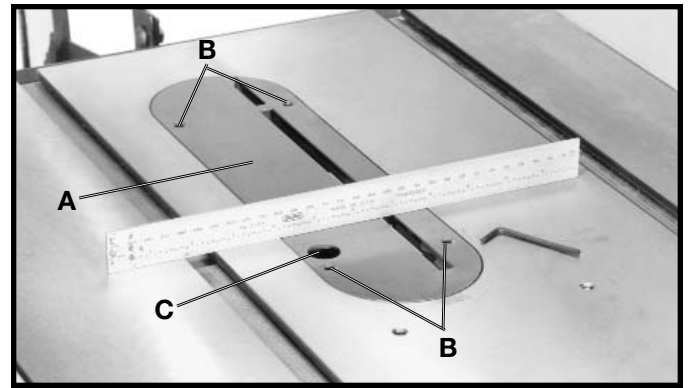

Fig. 68

MAINTENANCE

CHANGING THE SAW BLADE

⚠ WARNING USE ONLY 10" DIAMETER BLADES WITH 5/8" ARBOR HOLES, RATED AT 3450 RPM OR HIGHER.

⚠ WARNING DISCONNECT MACHINE FROM POWER SOURCE.

1. **NOTE:** Two 7/8" wrenches are supplied with the saw for changing the saw blade: a box end wrench (A) Fig. 69, and open end wrench (B).
2. Remove table insert (C) Fig. 69, and raise saw blade to its maximum height.
3. Place the open end wrench (B) Fig. 70, on the flats of the saw arbor to keep the arbor from turning, and using wrench (A), turn the arbor nut toward the front of the saw. Remove arbor nut, blade flange, and saw blade.
4. Assemble the new blade, making certain the teeth point down at the front of the saw table, and assemble outside blade flange and arbor nut. With wrench (B) Fig. 70, on the flats of the arbor to keep it from turning, tighten arbor nut by turning wrench (A) counterclockwise.
5. Replace table insert.

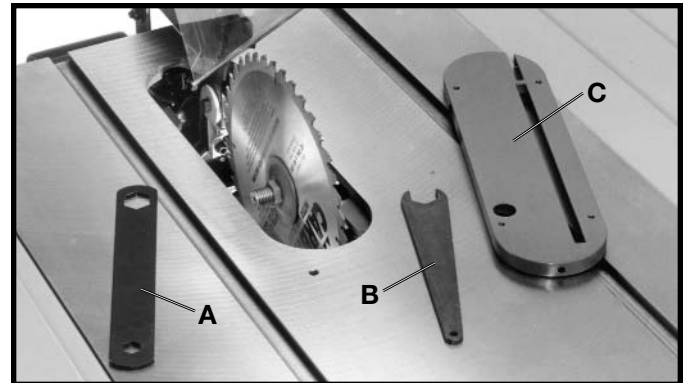

Fig. 69



Fig. 70

OVERLOAD PROTECTION

The motor recommended for use with your saw is equipped with a resettable overload relay (A) Fig. 71. If the motor shuts off or fails to start due to overloading (cutting stock too fast, using a dull blade, using the saw beyond its capacity, etc.), or low voltage, turn the switch to the "OFF" position, let the motor cool three to five minutes and push the reset button (A), which will reset the overload device. The motor can then be turned on again in the usual manner.



Fig. 71

OPERATIONS

Common sawing operations include ripping and crosscutting plus a few other standard operations of a fundamental nature. As with all power tools, there is a certain amount of hazard involved with the operation and use of the machine. Using the machine with the respect and caution demanded as far as safety precautions are concerned, will considerably lessen the possibility of personal injury. However, if normal safety precautions are overlooked or completely ignored, personal injury to the operator can result. The following information describes the safe and proper method for performing the most common sawing operations.

⚠ WARNING THE USE OF ATTACHMENTS AND ACCESSORIES NOT RECOMMENDED BY DELTA MAY RESULT IN THE RISK OF INJURY TO PERSONS.

CROSS-CUTTING

Cross-cutting requires the use of the miter gage to position and guide the work. Place the work against the miter gage and advance both the gage and work toward the saw blade, as shown in Fig. 79. The miter gage may be used in either table slot. When bevel cutting (blade tilted), use the left miter gage slot so that the blade tilts away from the miter gage and your hands.

Start the cut slowly and hold the work firmly against the miter gage and the table. One of the rules in running a saw is that you never hang onto or touch a free piece of work. Hold the supported piece, not the free piece that is cut off. The feed in cross-cutting continues until the work is cut in two, and the miter gage and work are pulled back to the starting point. Before pulling the work back, it is good practice to give the work a little sideways shift to move the work slightly away from the saw blade. Never pick up any short length of free work from the table while the saw is running. A smart operator never touches a cut-off piece unless it is at least a foot long.

For added safety and convenience the miter gage can be fitted with an auxiliary wood-facing (C), as shown in Fig. 80, that should be at least 1 inch higher than the maximum depth of cut, and should extend out 12 inches or more to one side or the other depending on which miter gage slot is being used. This auxiliary wood-facing (C) can be fastened to the front of the miter gage by using two wood screws (A) through the holes provided in the miter gage body and into the wood-facing.

⚠ CAUTION When using the block (B) Fig. 81, as a cut-off gage, it is very important that the rear end of the block be positioned so the work piece is clear of the block before it enters the blade.

⚠ WARNING NEVER USE THE FENCE AS A CUT-OFF GAGE WHEN CROSS-CUTTING.

When cross-cutting a number of pieces to the same length, a block of wood (B), can be clamped to the fence and used as a cut-off gage as shown in Fig. 81. It is important that this block of wood always be positioned in front of the saw blade as shown. Once the cut-off length is determined, secure the fence and use the miter gage to feed the work into the cut.

This block of wood allows the cut-off piece to move freely along the table surface without binding between the fence and the saw blade, thereby lessening the possibility of kickback and injury to the operator.



Fig. 79

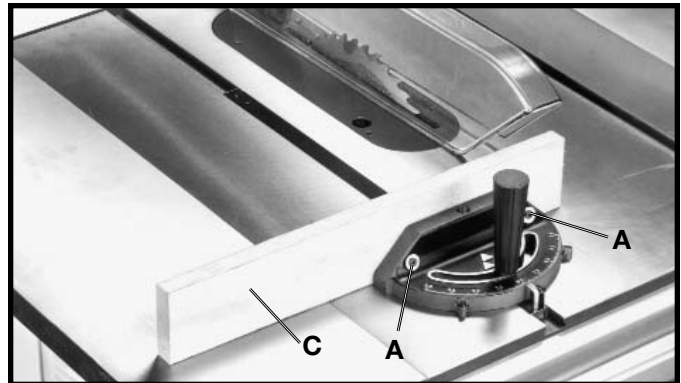

Fig. 80

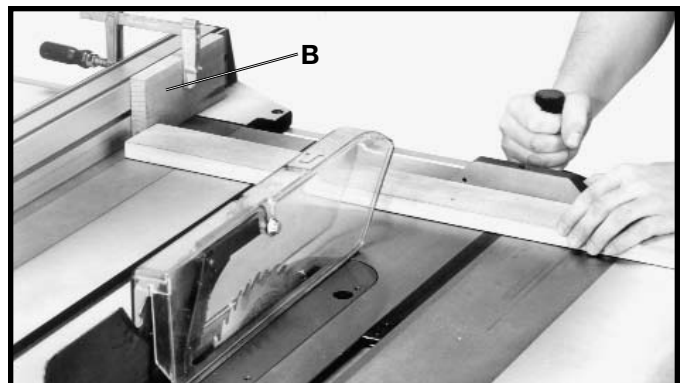

Fig. 81

RIPPING

Ripping is the operation of making a lengthwise cut through a board, as shown in Fig. 82, and the rip fence (A) is used to position and guide the work. One edge of the work rides against the rip fence while the flat side of the board rests on the table. Since the work is pushed along the fence, it must have a straight edge and make solid contact with the table. The saw guard must be used. The guard has anti-kickback fingers to prevent wood kickback, and a splitter to prevent the wood kerf from closing and binding the blade.

Start the motor and advance the work holding it down and against the fence. Never stand in the line of the saw cut when ripping. Hold the work and push it along the fence and into the saw blade as shown in Fig. 82. The work can then be fed through the saw blade with one or two hands. After the work is beyond the saw blade and anti-kickback fingers, the hand is removed from the work. When this is done the work will either stay on the table, tilt up slightly and be caught by the rear end of the guard or slide off the table to the floor. Alternately, the feed can continue to the end of the table, after which the work is lifted and brought back along the outside edge of the fence. The cut-off stock remains on the table and is not touched with the hands until the saw blade is stopped, unless it is a large piece allowing safe removal. When ripping boards longer than three feet, it is recommended that a work support be used at the rear of the saw to keep the workpiece from falling off the saw table.

CAUTION If the ripped work is less than 4 inches wide, a push stick should always be used to complete the feed, as shown in Fig. 83. The push stick can easily be made from scrap material as explained in the section "CONSTRUCTING A PUSH STICK."

When ripping material under 2 inches in width, a flat pushboard is a valuable accessory since ordinary type sticks may interfere with the blade guard. That flat pushboard can be made as shown in Fig. 83A.



Fig. 82



Fig. 83

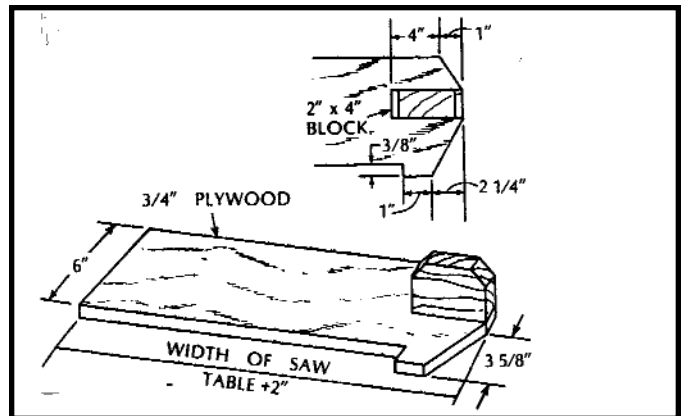

Fig. 83A

USING ACCESSORY MOULDING CUTTERHEAD

Moulding is cutting a shape on the edge or face of the work. Cutting mouldings with a moulding cutterhead in the circular saw is a fast, safe and clean operation. The many different knife shapes available make it possible for the operator to produce almost any kind of mouldings, such as various styles of corner moulds, picture frames, table edges, etc.

The moulding head consists of a cutterhead in which can be mounted various shapes of steel knives, as shown in Fig. 84. Each of the three knives in a set is fitted into a groove in the cutterhead and securely clamped with a screw. The knife grooves should be kept free of sawdust, which would prevent the cutter from seating properly.

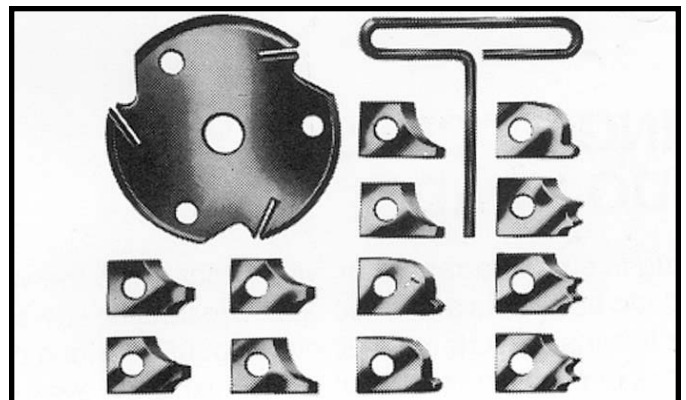

Fig. 84

⚠ WARNING For certain cutting operations such as dadoing and moulding where you are not cutting completely through the workpiece, the blade guard and splitter assembly cannot be used. Loosen screws (G) and (H) Fig. 85. Lift up and swing blade guard and splitter assembly (W) Fig. 86, to the rear of the saw, and then tighten screws (G) and (H).

⚠ WARNING Always return and fasten the blade guard and splitter assembly to its proper operating position for normal thru-sawing operations.

The moulding cutterhead (A) Fig. 87, is assembled to the saw arbor as shown.

⚠ WARNING THE OUTSIDE ARBOR FLANGE CAN NOT BE USED WITH THE MOULDING CUTTERHEAD, TIGHTEN THE ARBOR NUT AGAINST THE CUTTERHEAD BODY. DO NOT LOOSE THE OUTSIDE ARBOR FLANGE, FOR IT WILL BE NEEDED WHEN REATTACHING A BLADE TO THE SAW ARBOR. ALSO, THE ACCESSORY MOULDING CUTTERHEAD TABLE INSERT (B), MUST BE USED IN PLACE OF THE STANDARD TABLE INSERT.

CAUTION It is necessary when using the moulding cutterhead to add wood-facing (C) to the face of the rip fence, as shown in Fig. 88. The wood-facing is attached to the fence with fasteners, as shown. 3/4 inch stock is suitable for most work although an occasional job may require 1 inch facing.

Position the wood-facing over the cutterhead with the cutterhead below the surface of the table. Turn the saw on and raise the cutterhead. The cutterhead will cut its own groove in the wood-facing. Fig. 88, shows a typical moulding operation.

⚠ WARNING NEVER USE MOULDING CUTTER-HEAD IN A BEVEL POSITION.

⚠ WARNING NEVER RUN THE STOCK BETWEEN THE FENCE AND THE MOULDING CUTTERHEAD AS IRREGULAR SHAPED WOOD WILL CAUSE KICKBACK.

CAUTION When moulding end grain, the miter gage is used. The feed should be slowed up at the end of the cut to prevent splintering.

CAUTION In all cuts, attention should be given the grain, making the cut in the same direction as the grain whenever possible.

⚠ WARNING ALWAYS INSTALL BLADE GUARD AFTER OPERATION IS COMPLETE.

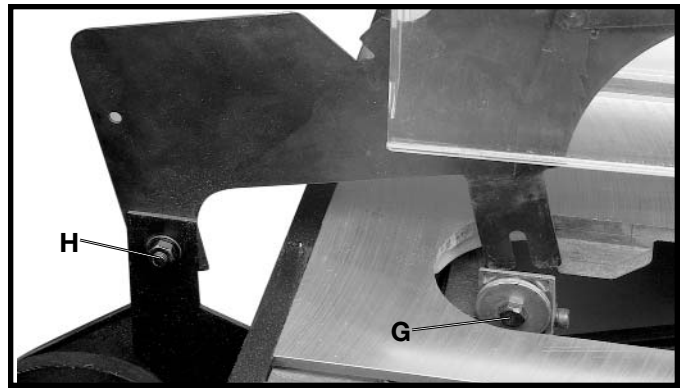

Fig. 85



Fig. 86

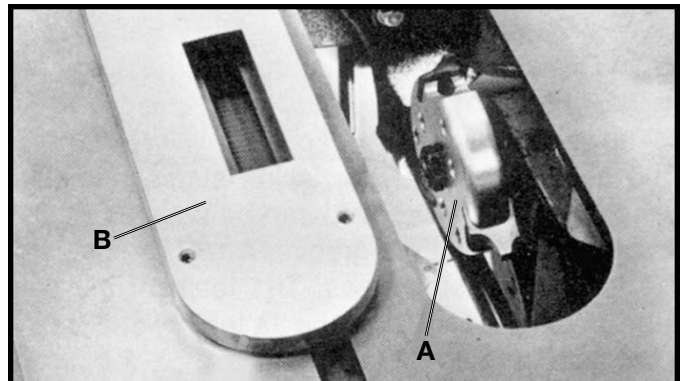

Fig. 87

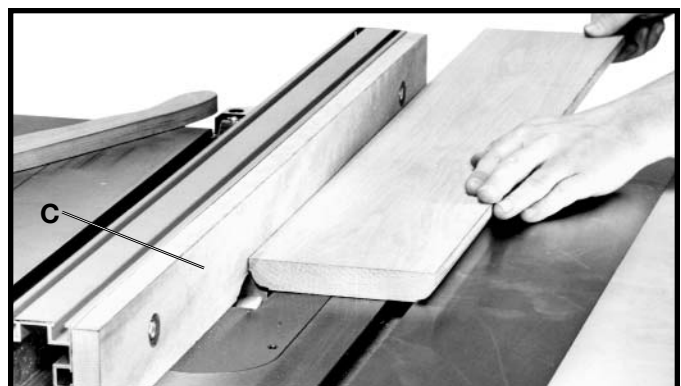

Fig. 88

USING ACCESSORY DADO HEAD

⚠ WARNING THE BLADE GUARD AND SPLITTER ASSEMBLY CANNOT BE USED WHEN DADOING OR MOULDING AND MUST BE REMOVED OR SWUNG TO THE REAR OF THE SAW.

Dadoing is cutting a rabbet or wide groove into the work. Most dado head sets are made up of two outside saws and four or five inside cutters, as shown in Fig. 89. Various combinations of saws and cutters are used to cut grooves from 1/8" to 13/16" for use in shelving, making joints, tenoning, grooving, etc. The cutters are heavily swaged and must be arranged so that this heavy portion falls in the gullets of the outside saws, as shown in Fig. 90. The saw and cutter overlap is shown in Fig. 91, (A) being the outside saw, (B) an inside cutter, and (C) a paper washer or washers which can be used as needed to control the exact width of groove. A 1/4" groove is cut by using the two outside saws. The teeth of the saws should be positioned so that the raker on one saw is beside the cutting teeth on the other saw.

The dado head set (D) Fig. 92, is assembled to the saw arbor as shown.

⚠ WARNING THE OUTSIDE ARBOR FLANGE CAN NOT BE USED WITH THE DADO HEAD SET, TIGHTEN THE ARBOR NUT AGAINST THE DADO HEAD SET BODY. DO NOT LOOSE THE OUTSIDE ARBOR FLANGE, FOR IT WILL BE NEEDED WHEN REATTACHING A BLADE TO THE SAW ARBOR. ALSO, THE ACCESSORY DADO HEAD SET TABLE INSERT (E) FIG. 92, MUST BE USED IN PLACE OF THE STANDARD TABLE INSERT.

⚠ WARNING THE BLADE GUARD AND SPLITTER ASSEMBLY CANNOT BE USED WHEN DADOING AND MUST BE REMOVED OR SWUNG TO THE REAR OF THE SAW AS EXPLAINED PREVIOUSLY IN THIS MANUAL. AUXILIARY JIGS, FIXTURES, PUSH STICKS AND FEATHER BOARDS SHOULD ALSO BE USED.

Fig. 93, shows a typical dado operation using the miter gage as a guide.

⚠ WARNING NEVER USE THE DADO HEAD IN A BEVEL POSITION.

⚠ WARNING ALWAYS INSTALL BLADE GUARD AFTER OPERATION IS COMPLETED.

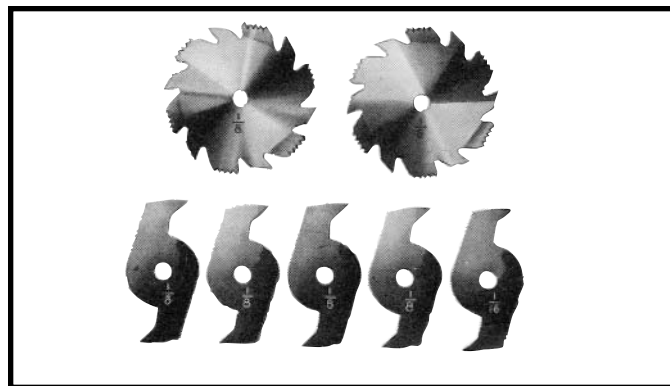

Fig. 89

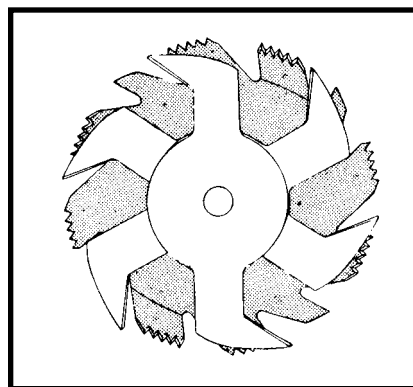

Fig. 90

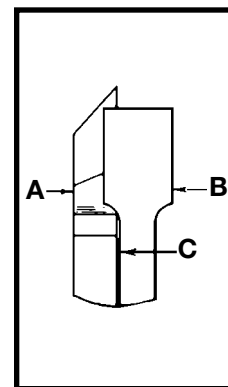

Fig. 91

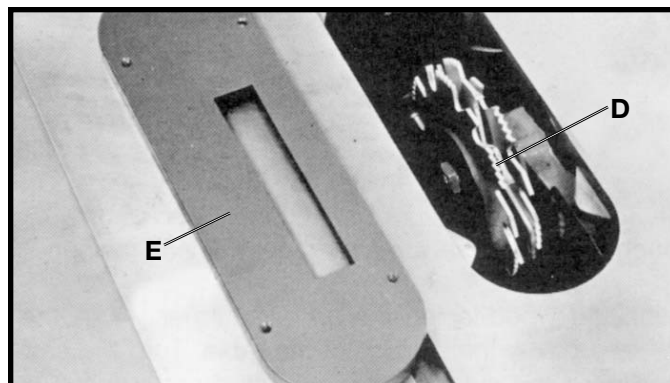

Fig. 92

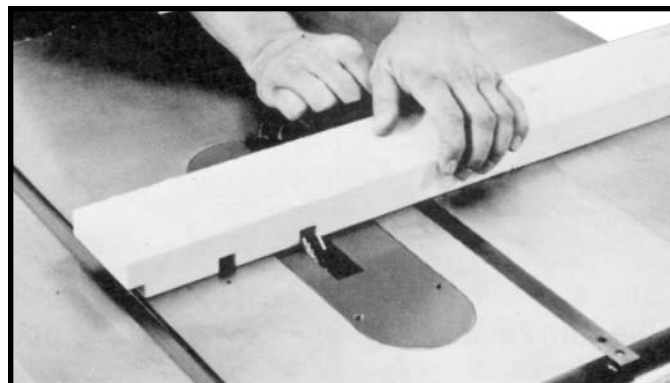

Fig. 93

USING AUXILIARY WOOD FACING ON RIP FENCE

CAUTION It is necessary when performing special operations such as moulding to add wood facing (A) Fig. 94, to one or both sides of the rip fence, as shown. The wood facing is attached to the fence with wood screws (B), countersunk and assembled through the holes provided in the fence. 3/4 inch stock is suitable for most work although an occasional job may require 1 inch facing.

CAUTION A wood facing should be used when ripping thin material such as paneling to prevent the material from catching between the bottom of the rip fence and the saw table surface.

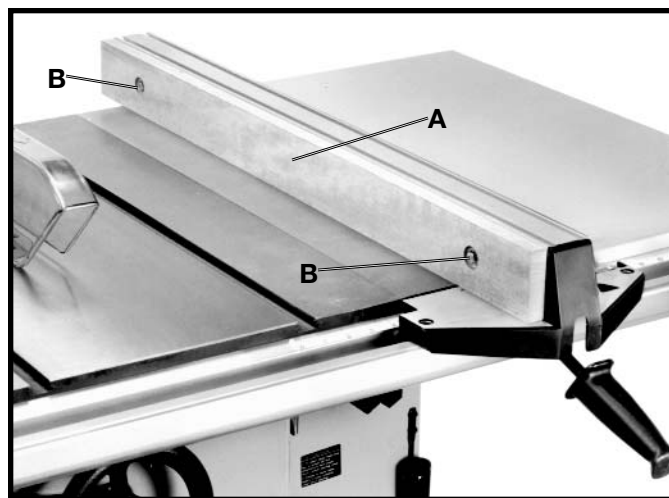

Fig. 94

CONSTRUCTING A FEATHERBOARD

Fig. 95, illustrates dimensions for making a typical featherboard. The material which the featherboard is constructed of, should be a straight piece of wood that is free of knots and cracks. Featherboards are used to keep the work in contact with the fence and table and help prevent kickbacks. Clamp the featherboards to the fence and table so that the leading edge of the featherboards will support the workpiece until the cut is completed.

WARNING Use featherboards for all non "thru-sawing" operations where the guard and spreader assembly must be removed (see Fig. 96). Always replace the guard and spreader assembly when the non thru-sawing operation is completed.

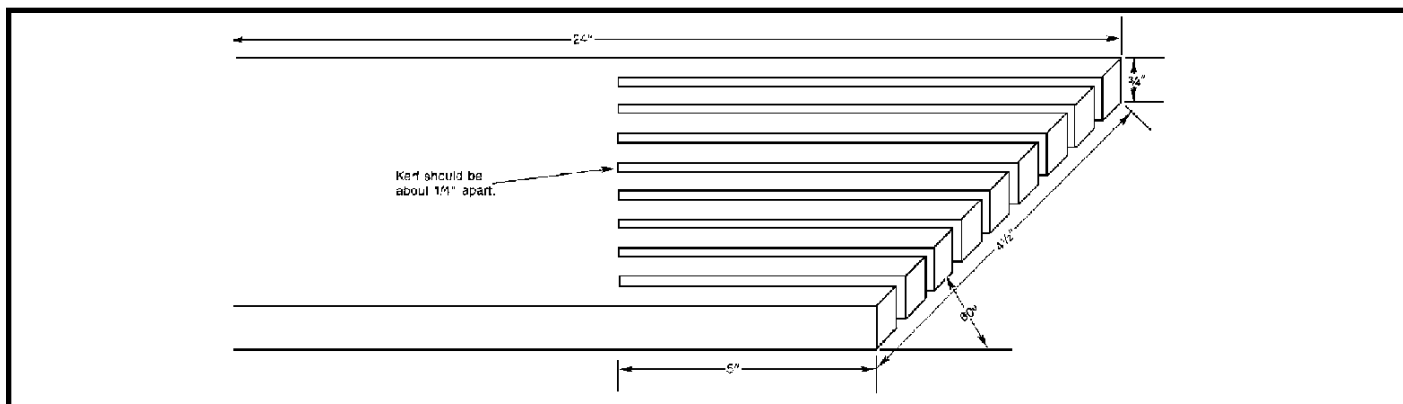

Fig. 95

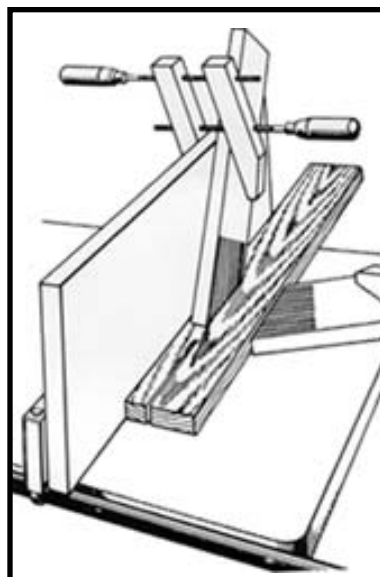
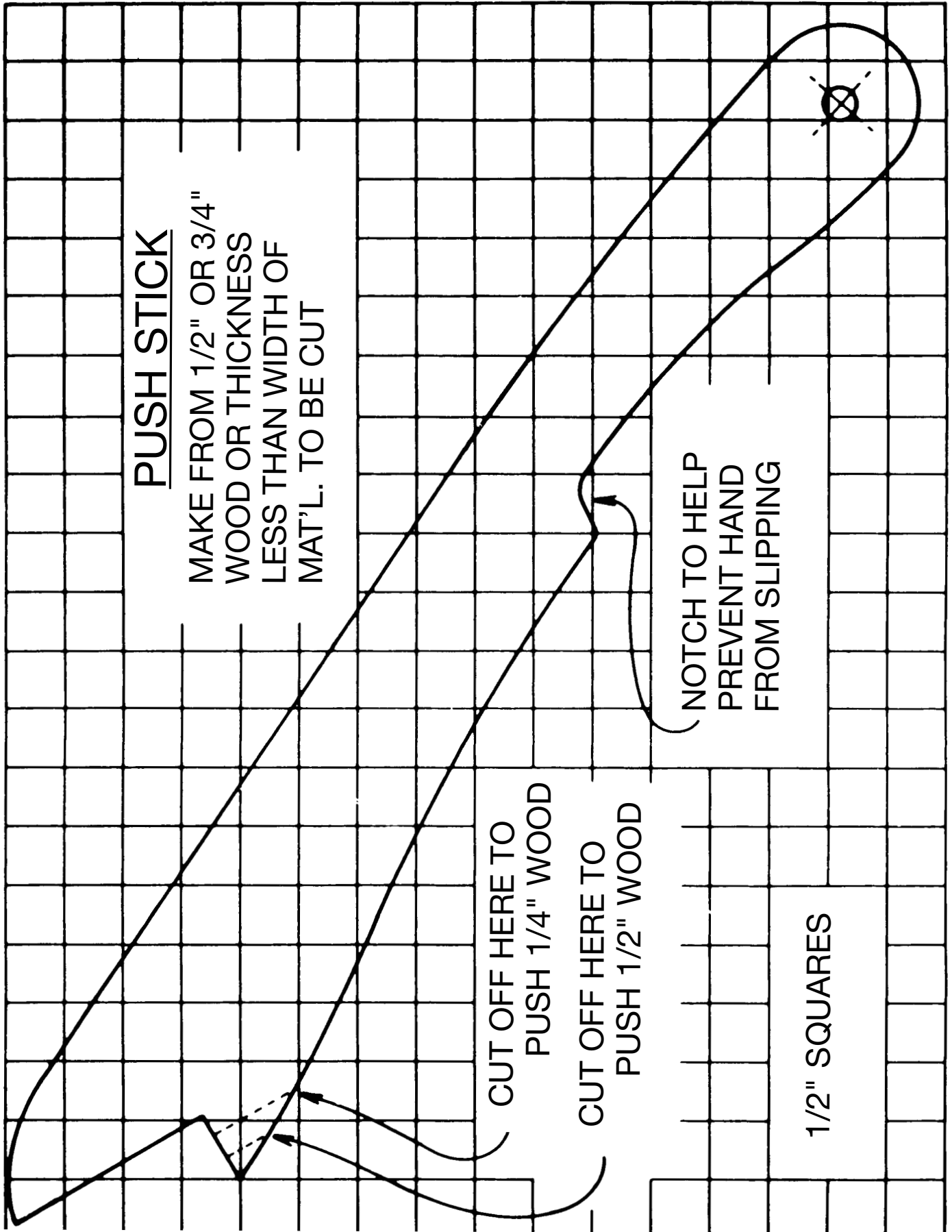

Fig. 96

CONSTRUCTING A PUSH STICK

⚠ WARNING When ripping work less than 4 inches wide, a push stick should be used to complete the feed and could easily be made from scrap material by following the pattern shown.



ACCESSORIES

A complete line of accessories is available from your Delta Supplier, Porter-Cable • Delta Factory Service Centers, and Delta Authorized Service Stations. Please visit our Web Site www.deltamachinery.com for a catalog or for the name of your nearest supplier.

▲WARNING Since accessories other than those offered by Delta have not been tested with this product, use of such accessories could be hazardous. For safest operation, only Delta recommended accessories should be used with this product.



PARTS, SERVICE OR WARRANTY ASSISTANCE

All Delta Machines and accessories are manufactured to high quality standards and are serviced by a network of Porter-Cable • Delta Factory Service Centers and Delta Authorized Service Stations. To obtain additional information regarding your Delta quality product or to obtain parts, service, warranty assistance, or the location of the nearest service outlet, please call 1-800-223-7278 (In Canada call 1-800-463-3582).



Two Year Limited Warranty

Delta will repair or replace, at its expense and at its option, any Delta machine, machine part, or machine accessory which in normal use has proven to be defective in workmanship or material, provided that the customer returns the product prepaid to a Delta factory service center or authorized service station with proof of purchase of the product within two years and provides Delta with reasonable opportunity to verify the alleged defect by inspection. Delta may require that electric motors be returned prepaid to a motor manufacturer's authorized station for inspection and repair or replacement. Delta will not be responsible for any asserted defect which has resulted from normal wear, misuse, abuse or repair or alteration made or specifically authorized by anyone other than an authorized Delta service facility or representative. Under no circumstances will Delta be liable for incidental or consequential damages resulting from defective products. This warranty is Delta's sole warranty and sets forth the customer's exclusive remedy, with respect to defective products; all other warranties, express or implied, whether of merchantability, fitness for purpose, or otherwise, are expressly disclaimed by Delta.

NOTES

PORTER-CABLE • DELTA SERVICE CENTERS (CENTROS DE SERVICIO DE PORTER-CABLE • DELTA)

Parts and Repair Service for Porter-Cable • Delta Machinery are Available at These Locations
(Obtenga Refaccion de Partes o Servicio para su Herramienta en los Siguietes Centros de Porter-Cable • Delta)

ARIZONA

Tempe 85282 (Phoenix)
2400 West Southern Avenue
Suite 105
Phone: (602) 437-1200
Fax: (602) 437-2200

CALIFORNIA

Ontario 91761 (Los Angeles)
3949A East Guasti Road
Phone: (909) 390-5555
Fax: (909) 390-5554

San Leandro 94577 (Oakland)
3039 Teagarden Street
Phone: (510) 357-9762
Fax: (510) 357-7939

COLORADO

Arvada 80003 (Denver)
8175 Sheridan Blvd., Unit S
Phone: (303) 487-1809
Fax: (303) 487-1868

FLORIDA

Davie 33314 (Miami)
4343 South State Rd. 7 (441)
Unit #107
Phone: (954) 321-6635
Fax: (954) 321-6638

Tampa 33609

4538 W. Kennedy Boulevard
Phone: (813) 877-9585
Fax: (813) 289-7948

GEORGIA

Forest Park 30297 (Atlanta)
5442 Frontage Road,
Suite 112
Phone: (404) 608-0006
Fax: (404) 608-1123

ILLINOIS

Addison 60101 (Chicago)
400 South Rohlwing Rd.
Phone: (630) 424-8805
Fax: (630) 424-8895

Woodridge 60517 (Chicago)

2033 West 75th Street
Phone: (630) 910-9200
Fax: (630) 910-0360

MARYLAND

Elkridge 21075 (Baltimore)
7397-102 Washington Blvd.
Phone: (410) 799-9394
Fax: (410) 799-9398

MASSACHUSETTS

Braintree 02185 (Boston)
719 Granite Street
Phone: (781) 848-9810
Fax: (781) 848-6759

Franklin 02038 (Boston)

Franklin Industrial Park
101E Constitution Blvd.
Phone: (508) 520-8802
Fax: (508) 528-8089

MICHIGAN

Madison Heights 48071 (Detroit)
30475 Stephenson Highway
Phone: (248) 597-5000
Fax: (248) 597-5004

MINNESOTA

Minneapolis 55429
5522 Lakeland Avenue North
Phone: (763) 561-9080
Fax: (763) 561-0653

MISSOURI

North Kansas City 64116
1141 Swift Avenue
Phone: (816) 221-2070
Fax: (816) 221-2897

St. Louis 63119

7574 Watson Road
Phone: (314) 968-8950
Fax: (314) 968-2790

NEW YORK

Flushing 11365-1595 (N.Y.C.)
175-25 Horace Harding Expwy.
Phone: (718) 225-2040
Fax: (718) 423-9619

NORTH CAROLINA

Charlotte 28270
9129 Monroe Road, Suite 115
Phone: (704) 841-1176
Fax: (704) 708-4625

OHIO

Columbus 43214
4560 Indianola Avenue
Phone: (614) 263-0929
Fax: (614) 263-1238

Cleveland 44125
8001 Sweet Valley Drive
Unit #19
Phone: (216) 447-9030
Fax: (216) 447-3097

OREGON

Portland 97230
4916 NE 122 nd Ave.
Phone: (503) 252-0107
Fax: (503) 252-2123

PENNSYLVANIA

Willow Grove 19090
520 North York Road
Phone: (215) 658-1430
Fax: (215) 658-1433

TEXAS

Carrollton 75006 (Dallas)
1300 Interstate 35 N, Suite 112
Phone: (972) 446-2996
Fax: (972) 446-8157

Houston 77055

West 10 Business Center
1008 Wirt Road, Suite 120
Phone: (713) 682-0334
Fax: (713) 682-4867

WASHINGTON

Auburn 98001 (Seattle)
3320 West Valley HWY, North
Building D, Suite 111
Phone: (253) 333-8353
Fax: (253) 333-9613

Authorized Service Stations are located in many large cities. Telephone **800-438-2486** or **731-541-6042** for assistance locating one. Parts and accessories for Porter-Cable-Delta products should be obtained by contacting any Porter-Cable-Delta Distributor, Authorized Service Center, or Porter-Cable-Delta Factory Service Center. If you do not have access to any of these, call **800-223-7278** and you will be directed to the nearest Porter-Cable-Delta Factory Service Center. Las Estaciones de Servicio Autorizadas están ubicadas en muchas grandes ciudades. Llame al **800-438-2486** ó al **731-541-6042** para obtener asistencia a fin de localizar una. Las piezas y los accesorios para los productos Porter-Cable-Delta deben obtenerse poniéndose en contacto con cualquier distribuidor Porter-Cable-Delta, Centro de Servicio Autorizado o Centro de Servicio de Fábrica Porter-Cable-Delta. Si no tiene acceso a ninguna de estas opciones, llame al **800-223-7278** y le dirigirán al Centro de Servicio de Fábrica Porter-Cable-Delta más cercano.

CANADIAN PORTER-CABLE • DELTA SERVICE CENTERS

ALBERTA

Bay 6, 2520-23rd St. N.E.
Calgary, Alberta
T2E 8L2
Phone: (403) 735-6166
Fax: (403) 735-6144

BRITISH COLUMBIA

8520 Baxter Place
Burnaby, B.C.
V5A 4T8
Phone: (604) 420-0102
Fax: (604) 420-3522

MANITOBA

1699 Dublin Avenue
Winnipeg, Manitoba
R3H 0H2
Phone: (204) 633-9259
Fax: (204) 632-1976

ONTARIO

505 Southgate Drive
Guelph, Ontario
N1H 6M7
Phone: (519) 836-2840
Fax: (519) 767-4131

QUÉBEC

1515 ave.
St-Jean Baptiste,
Québec, Québec
G2E 5E2
Phone: (418) 877-7112
Fax: (418) 877-7123

1447, Begin
St-Laurent, (Montréal),
Québec
H4R 1V8
Phone: (514) 336-8772
Fax: (514) 336-3505

The following are trademarks of PORTER-CABLE-DELTA (Las siguientes son marcas registradas de PORTER-CABLE S.A.): Auto-Set®, BAMMER®, B.O.S.S.®, Builder's Saw®, Contractor's Saw®, Contractor's Saw II™, Delta®, DELTACRAFT®, DELTAGRAM™, Delta Series 2000™, DURATRONIC™, Emc2™, FLEX®, Flying Chips™, FRAME SAW®, Homecraft®, INNOVATION THAT WORKS®, Jet-Lock®, JETSTREAM®, 'kickstand®, LASERLOC®, MICRO-SET®, Micro-Set®, MIDI LATHE®, MORTEN™, NETWORK™, OMNIJIG®, POCKET CUTTER®, PORTA-BAND®, PORTA-PLANE®, PORTER-CABLE®(design), PORTER-CABLE®PROFESSIONAL POWER TOOLS, Posi-Matic®, Q-3®(design), QUICKSAND®(design), QUICKSET™, QUICKSET II®, QUICKSET PLUS™, RIPTIDE™(design), SAFE GUARD II®, SAFE-LOC®, Sanding Center®, SANDTRAP®(design), SAW BOSS®, Sawbuck™, Sidekick®, SPEED-BLOC®, SPEEDMATIC®, SPEEDTRONIC®, STAIR EASE®, The American Woodshop®(design), The Lumber Company®(design), THE PROFESSIONAL EDGE®, THE PROFESSIONAL SELECT®, THIN-LINE™, TIGER®, TIGER CUB®, TIGER SAW®, TORQBUSTER®, TORQ-BUSTER®, TRU-MATCH™, TWIN-LITE®, UNIGUARD®, Unifence®, UNIFEEDER™, Unihead®, Uniplane™, Unirip®, Unisaw®, Univise®, Versa-Feeder®, VERSA-PLANE®, WHISPER SERIES®, WOODWORKER'S CHOICE™.

Trademarks noted with ™ and ® are registered in the United States Patent and Trademark Office and may also be registered in other countries. Las Marcas Registradas con el signo de ™ y ® son registradas por la Oficina de Registros y Patentes de los Estados Unidos y también pueden estar registradas en otros países.

Printed in U.S.A.

Free Manuals Download Website

<http://myh66.com>

<http://usermanuals.us>

<http://www.somanuals.com>

<http://www.4manuals.cc>

<http://www.manual-lib.com>

<http://www.404manual.com>

<http://www.luxmanual.com>

<http://aubethermostatmanual.com>

Golf course search by state

<http://golfingnear.com>

Email search by domain

<http://emailbydomain.com>

Auto manuals search

<http://auto.somanuals.com>

TV manuals search

<http://tv.somanuals.com>