

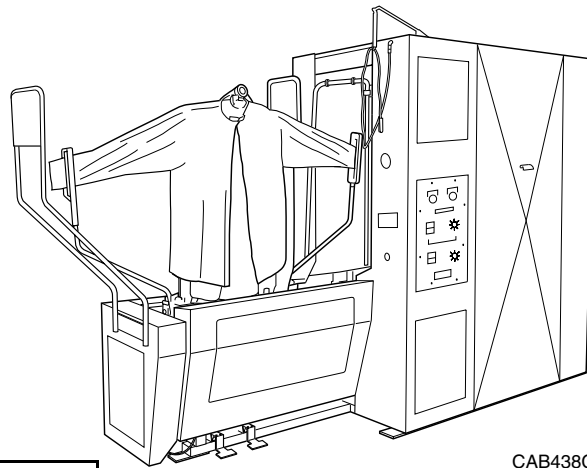

# Combination Sleever, Bosom, Body and Yoke Press

CSBBYMV



CAB438C

	<b>WARNING</b>
<b>Read and understand these instructions before operating or servicing these machines.</b>	

**Keep These Instructions for Future Reference.**

(If this machine changes ownership, this manual must accompany machine.)



An LSG Company  
831 South First Street, P.O. Box 32270  
Louisville, KY 40232-2270  
Phone: (502) 587-1292  
Sales Fax: (502) 585-3625  
Service/Parts Fax: (502) 681-1275

[www.cissellmfg.com](http://www.cissellmfg.com)

Part No. AJ0975  
March 2004



# Table of Contents

<b>Safety Information</b> .....	3
Explanation of Safety Messages.....	3
Important Safety Instructions .....	3
<b>Operation</b> .....	5
Front View of CSBBYMV .....	5
Rear View of CSBBYMV .....	6
Operating Controls and Indicators.....	7
Operating Controls and Indicators .....	8
Resetting Air Circuit.....	10
Pressing Short Sleeve Shirts .....	10
Operating Instructions .....	11
Pre-Operating Services .....	11
Post-Operating Services.....	12
Cleaning Press Heads.....	12
CSBBYMV Operation Sequence.....	13
Buck Dressing Instructions .....	14
Operating Tips .....	18
Shirt Quality.....	18
Padding .....	19
Quality Troubleshooting.....	20
<b>Maintenance</b> .....	23
General.....	23
Periodic Inspections.....	23
Periodic Inspections .....	24
Cleaning Air Filter .....	25
Cleaning Steam Strainer .....	25
Cleaning Customer-Furnished Steam Traps .....	25
Lubrication.....	26
Monthly Lubrication.....	28
Adjusting Air Line Lubricator Flow Rate.....	28
Filling Air Line Lubricator .....	29

© Copyright 2004, Alliance Laundry Systems LLC

All rights reserved. No part of the contents of this book may be reproduced or transmitted in any form or by any means without the expressed written consent of the publisher.





# Safety Information

## Explanation of Safety Messages

Precautionary statements (“DANGER,” “WARNING,” and “CAUTION”), followed by specific instructions, are found in this manual and on machine decals. These precautions are intended for the personal safety of the operator, user, servicer, and those maintaining the machine.

	<b>DANGER</b>
Indicates an imminently hazardous situation that, if not avoided, will cause severe personal injury or death.	

	<b>WARNING</b>
Indicates a hazardous situation that, if not avoided, could cause severe personal injury or death.	

	<b>CAUTION</b>
Indicates a hazardous situation that, if not avoided, may cause minor or moderate personal injury or property damage.	

Additional precautionary statements (“IMPORTANT” and “NOTE”) are followed by specific instructions.

**IMPORTANT:** The word “IMPORTANT” is used to inform the reader of specific procedures where minor machine damage will occur if the procedure is not followed.

**NOTE:** The word “NOTE” is used to communicate installation, operation, maintenance or servicing information that is important but not hazard related.

## Important Safety Instructions

Save These Instructions

	<b>WARNING</b>
<b>Failure to install, maintain, and/or operate this machine according to manufacturer’s instructions may result in conditions which can produce serious injury, death and/or property damage.</b>	

**NOTE:** The WARNING and IMPORTANT instructions appearing in this manual are not meant to cover all possible conditions and situations that may occur. It must be understood that common sense, caution, and carefulness are factors which CANNOT be built into this press. These factors MUST BE supplied by the person(s) installing, maintaining or operating the ironer.

Always contact your dealer, distributor, service agent, or the manufacturer on any problems or conditions you do not understand.

Always contact your dealer, distributor, service agent, or the manufacturer on any problems or conditions you do not understand.

1. Read all instructions before using the press.
2. Refer to the GROUNDING INSTRUCTIONS in the INSTALLATION manual for the proper grounding of the press.
3. Do not allow children to play on or in the press.
4. Do not reach into the press while the press is in operation.
5. Do not install or store the press where it will be exposed to water and/or weather.
6. Do not tamper with the controls.
7. Do not repair or replace any part of the press, or attempt any servicing unless specifically recommended in the user-maintenance instructions or in published user-repair instructions that the user understands and has the skills to carry out.
8. To reduce the risk of an electric shock or fire, DO NOT use an extension cord or an adapter to connect the press to the electrical power source.

## Safety Information

9. Use press only for its intended purpose, finishing garments.
10. ALWAYS disconnect the press from electrical supply before attempting any service. Disconnect the power cord by grasping the plug, not the cord.
11. Install the press according to the INSTALLATION INSTRUCTIONS. All connections for steam, electrical power and grounding must comply with local codes and be made by licensed personnel when required.
12. Replace worn power cords and/or loose plugs.
13. Never operate the press with any guards and/or panels removed.
14. DO NOT operate the press with missing or broken parts.
15. DO NOT bypass any safety devices.
16. Failure to install, maintain, and/or operate this press according to the manufacturer's instructions may result in conditions which can produce bodily injury and/or property damage.

**NOTE: The WARNINGS and IMPORTANT SAFETY INSTRUCTIONS appearing in this manual are not meant to cover all possible conditions and situations that may occur. Common sense, caution and care must be exercised when installing, maintaining, or operating the press.**

Any problems or conditions not understood should be reported to the dealer, distributor, service agent or the manufacturer.

# Operation

## Front View of CSBBYMV

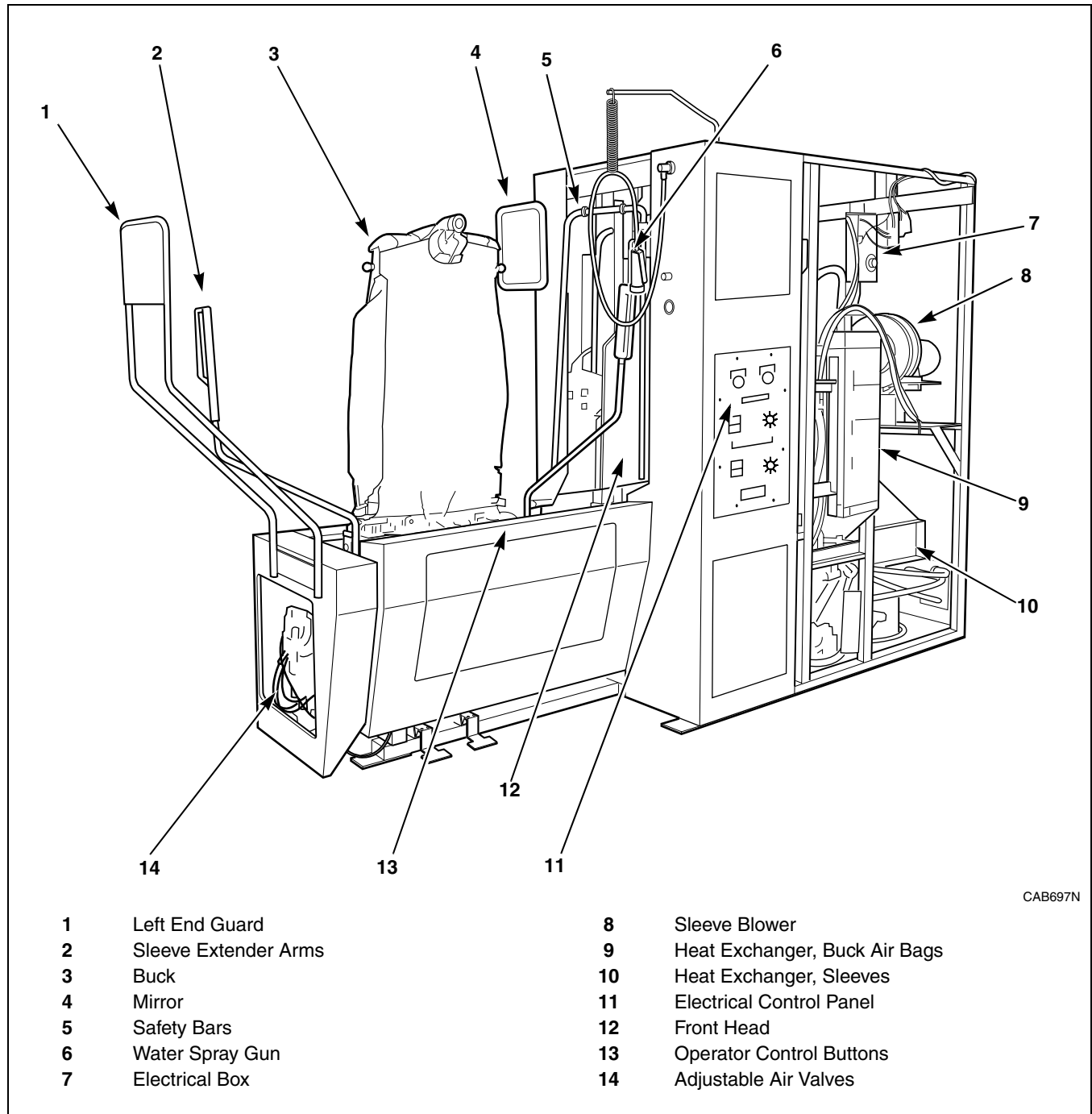

Figure 1

## Rear View of CSBBYMV

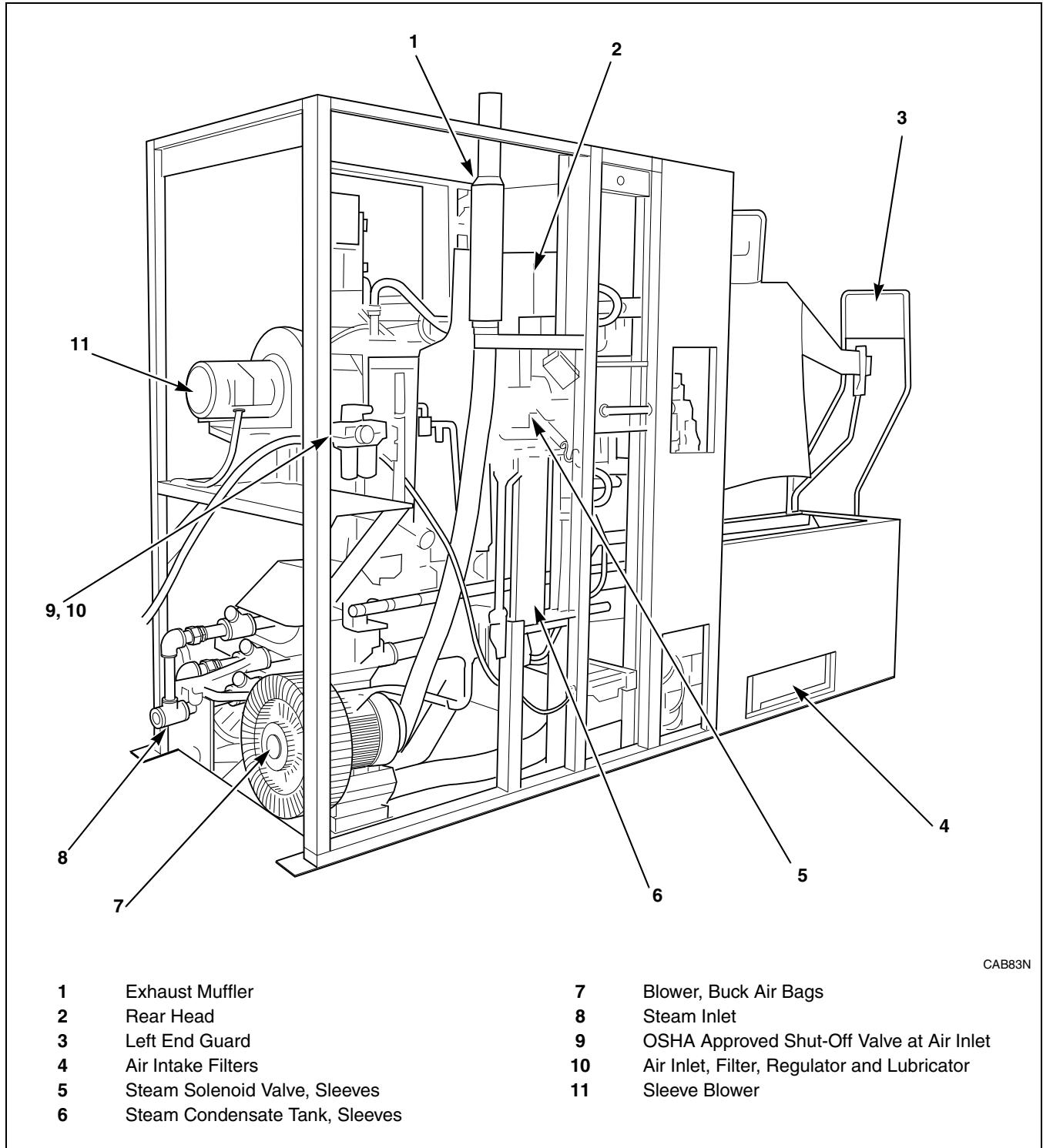

Figure 2



# Operating Controls and Indicators

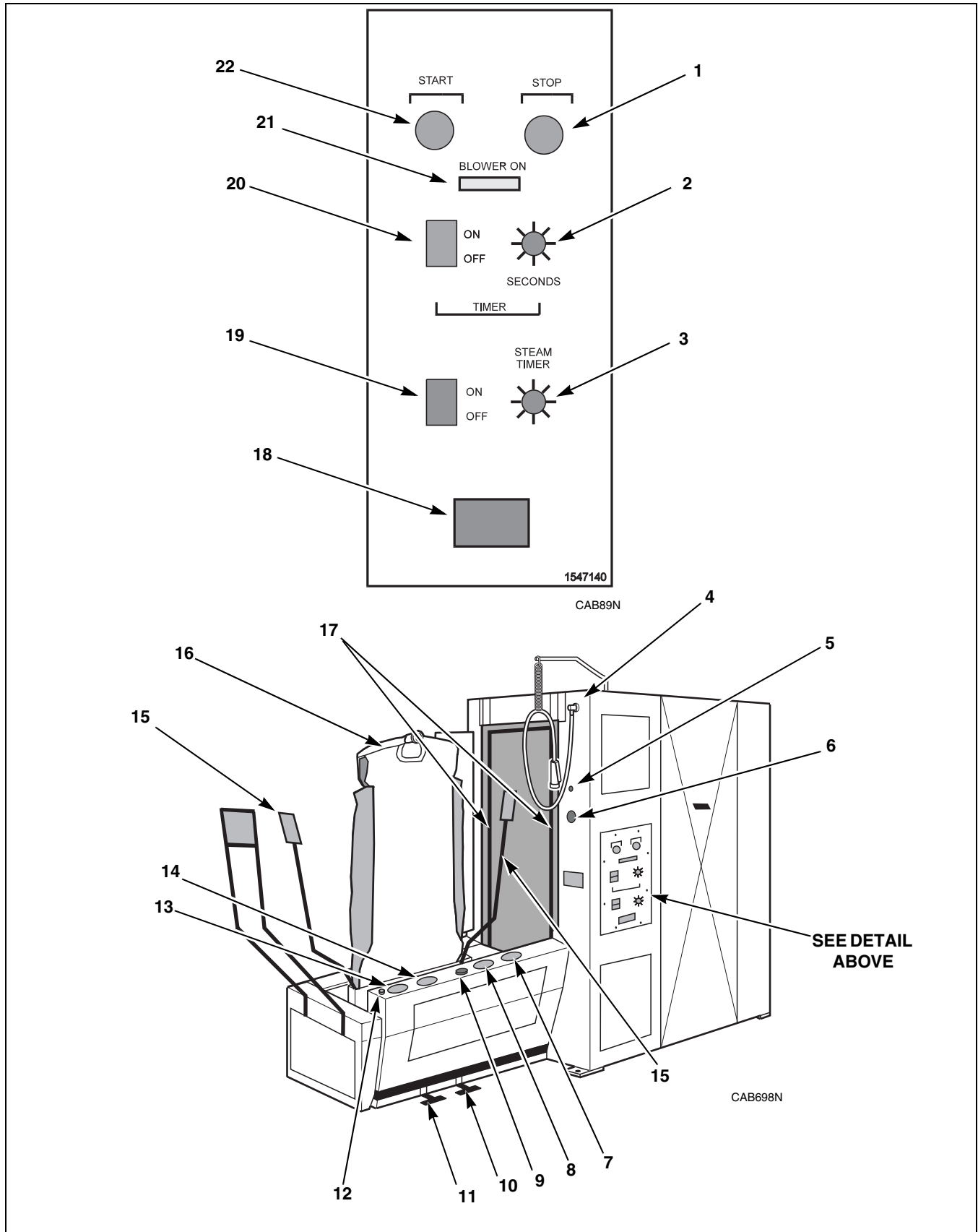

Figure 3

## Operation

### Operating Controls and Indicators

Refer to *Figure 3*.

Controls or Indicators	Function	Position or Indication
1. Red stop button	Stops electrical service to blowers, timers, and heat exchanger.	Press to actuate.
2. Cycle timer control knob	Determines pressing cycle time.	Rotate knob to desired setting.
3. Steam timer control knob	Determines the length of sleeve steaming time. Normally set at 5 seconds.	Rotate knob to desired setting.
4. Water gun needle valve	Turns water on and off to water spray gun.	Turn clockwise to turn water off. Turn counterclockwise to turn water on.
5. Reset button	Energizes the air power control circuit. Press must be reset if press gauge (item 6) registers 0 psi.	With buck in the out position, press reset button.
6. Gauge, reset system	Indicates that air power is on or off to press.	When gauge shows line pressure, air is reset to press. When gauge shows zero pressure, air must be reset for press to operate.
7. Right gray buck in button	When pressed simultaneously with the left gray buck in button (item 13), moves buck from dressing position to pressing position inside cabinet.	Press simultaneously with left gray buck in button (item 13) to actuate.
8. Black vacuum release button	Turns vacuum off to buck.	Press to actuate.
9. Emergency Stop button	Exhausts entire air system except for air to collar clamp air cylinder. Stops buck travel and opens press heads or keeps press heads from closing. Press will not operate until air circuit is reset. (Applies to machines produced after 1997.)	Press to actuate. Turn in direction of arrow on button to reset. Button will pop up after approximately 1/8 turn.
10. Collar clamp foot pedal	Opens clamping arm on collar clamp (item 16).	Depress foot pedal to open collar clamp. Release foot pedal to close collar clamp.
11. Sleeve extender/vacuum foot pedal	Moves the sleeve extenders out and turns vacuum on to buck.	Depress foot pedal to actuate.
12. Sleeve extender release button	Retracts sleeve extenders, which brings them in toward the buck. Should be actuated before dressing shirt on buck.	Press to actuate.
13. Left gray buck in button	When pressed simultaneously with the right gray buck in button (item 7), moves buck from dressing position to pressing position inside cabinet.	Press simultaneously with right gray buck in button (item 7) to actuate.
14. Red head release button	Opens the press heads. Buck will automatically return to the dressing position when heads open.	Press to actuate.

Table 1 (Continued)

Table 1 (Continued)

Controls or Indicators	Function	Position or Indication
15. Sleeve extender rods	Clamp cuffs and extend sleeves outward for high quality finish.	Extend shirt sleeves via foot pedal (item 11). Retract sleeve extender arms via sleeve extender button (item 12).
16. Collar clamp	Holds shirt collar in place on buck (refer to item 10).	Open and close clamp with foot pedal (item 10).
17. Safety bars	Exhausts entire air system except air to collar clamp air cylinder. Stops buck travel, and opens press heads or keeps press heads from closing. Press will not operate until air circuit is reset.	Press to actuate.
18. Counter	Registers number of garments pressed.	Works only when timer is on.
19. Steam timer selector switch	Turns steam timer on and off.	Push to on or off position.
20. Cycle timer selector switch	Turns cycle timer on and off.	Push to on or off position.
21. Indicator lamp	Indicates electrical service is on or off to blowers, timers, and heat exchanger.	Illuminates to indicate electrical power is present.
22. Black start button	If air is reset to press, applies electrical service to blower and timers. If air is not reset to press, start button will not operate.	Press to actuate.

## Operation

### Resetting Air Circuit

The air circuit must be reset before press can be used. Resetting is required if:

- Press has been shut down.
- Any safety bar or red emergency stop button has been activated.
- Gauge indicates 0 air pressure.

To reset air to press:

Move buck to dressing position by hand.

Turn red emergency stop button in direction of arrows until it pops up.

Press reset button. Air should reset and line pressure (approximately 65 psi [4.48 bar]) should register on gauge.

**NOTE: If press does not reset, call a qualified service technician.**

### Pressing Short Sleeve Shirts

Sleeve extender arms are not used when a short sleeve shirt is dressed on the buck. The operator should turn the steam timer selector switch to the off position to stop live steam and sleeve blower air through sleeve armhole.

	<b>CAUTION</b>
<p><b>To avoid possible injury:</b></p> <ul style="list-style-type: none"><li>• <b>ALWAYS</b> turn <b>STEAM</b> Timer Selector switch <b>OFF</b> when pressing short sleeve shirts.</li><li>• <b>ALWAYS</b> stand clear of live steam when sending buck into pressing cabinet.</li></ul>	
<small>W441</small>	

## Operating Instructions

These instructions will provide the best shirt pressing quality and prolong padding life.

### Pre-Operating Services

Perform the following services daily before using the press:

1. Check condition of buck padding and air bags.  
Replace if:
  - Cover is scorched or torn.
  - Air bags have holes.
  - Flannel is hard or brittle (not springy).
2. While steam and air are off and heads are cool, remove debris that may have fallen inside press. Remove all lint.
3. Open shut-off valves in steam supply and return lines. Allow 15 to 20 minutes for press to heat.

**NOTE: Open shut-off valves slowly to prevent water hammer.**

4. Open valve(s) in air supply line and reset press.

	<b>CAUTION</b>
<b>To avoid possibly serious injury, ALWAYS turn STEAM Timer Selector switch to OFF position during pre-operating services.</b>	
<small>W442</small>	

5. Turn off steam to buck steam sleeve openings by pressing the steam timer selector switch to the off position.
6. Simultaneously press and release both gray buck in buttons. As buck travels into cabinet, press safety bar located near the operator. Buck should stop; press heads should remain open; and air should exhaust from system. Pressure gauge should read 0.

**NOTE: It is necessary to pull buck back to dressing position before resetting the press.**

7. Reset air to press. Simultaneously press and release both gray buck in buttons. Allow buck to travel into cabinet and heads to close. Press other safety bar. Press heads should open; buck should remain stationary gauge should read 0.

**NOTE: It is necessary to pull buck back to dressing position before resetting the press.**

	<b>WARNING</b>
<b>To avoid possible serious injury NEVER use press unless BOTH safety bars are working properly.</b>	
<small>W375</small>	

8. Reset air to press. Send buck into cabinet. Allow buck to travel into cabinet and heads to close. Press emergency stop button. Press heads should open; buck should remain stationary. Pressure GAUGE should read 0.

**NOTE: It is necessary to pull buck back to dressing position before resetting the press.**

9. Reset air to press.

**NOTE: Emergency stop button must be reset after it is actuated. Turn in the direction as indicated by the button. Continue turning until button pops up.**

10. Preheat buck prior to starting production.

**IMPORTANT: Preheating the buck will prevent water build-up in sleeve blower system, as well as provide the best shirt production. Without preheating, water can discharge from buck on nearby garments.**

11. Mist air bags with water and send unloaded buck into pressing cabinet. Repeat 3 or 4 times to preheat bucks and prolong life of air bags.

**NOTE: Repeat step 10 if buck has not been in operation for more than 30 minutes.**

12. Close customer-furnished electrical disconnect switch or set circuit breaker(s).
13. Start blower by pressing black start button. Allow blower to run for 5 minutes.

## Operation

### Post-Operating Services

Perform the following services after the final operation of the day or anytime press will be idle for an extended period of time:

1. Turn off steam to buck sleeve openings by pressing the steam Timer Selector switch to the off position.
2. Mist air bags with water and send unloaded buck into pressing cabinet (this will prolong the life of the air bag and eliminate formation of wrinkles in air bags). Repeat 4 times.
3. Press one safety bar to relieve air pressure and stop blower.
4. Open customer-furnished electrical disconnect switch or trip the circuit breaker.
5. Close steam shut-off valve.
6. Close shut-off valve at air inlet.
7. Clean buck padding with a damp cloth. Check condition of buck padding and air bags. Replace padding if:
  - Cover is scorched or torn.
  - Bags have holes.
  - Flannel is hard or brittle (not springy).
8. Clean press heads if required.

### Cleaning Press Heads

Press heads require cleaning if:

- Discoloration transfers from head to shirts.
- Shirts stick to heads as the heads open.

Once precautions listed in these WARNINGS have been met, follow directions provided with surface cleaner to clean press heads.

	<b>WARNING</b>
<b>To avoid possible serious injury, heads should be cleaned <u>ONLY</u> by properly trained personnel.</b>	
W376	

	<b>WARNING</b>
<b>To avoid possible serious injury, ALWAYS shut off services to press <u>BEFORE</u> removing guards and covers to clean press heads.</b>	
<ul style="list-style-type: none"><li>● Shut off AND lock out ALL electrical power to press.</li><li>● Shut off AND lock out ALL air pressure to press using the relieving shut-off valve at air supply inlet.</li><li>● Reduce steam pressure to 0 AND lock out steam supply to press.</li><li>● Let heated surfaces cool.</li></ul>	
W377	

	<b>WARNING</b>
<b>If using a surface cleaner which requires heat to the press, use an industry approved heat protective mitt or other heat protective device as press heads are cooling down.</b>	
W378	

## CSBBYMV Operation Sequence

### Single Operator. Refer to *Figure 4*.

A typical single operator shirt station consists of:

- One CSBBYMV sleeve, bosom, body and yoke press
- One collar and cuff press (CUCC)
- One collar post
- One damp box

To increase operator productivity (with less fatigue) position the items listed above as shown in *Figure 4*.

Set timers as follows:

- Steam timer – 5 seconds
- Cycle timer – 35 seconds (100% cotton)
- Cycle timer – 25 seconds (Blends)

**NOTE: Pressing and steam times may vary based on:**

- **Steam pressure at the press. Ideally, steam pressure at press should be 105-115 psi (7.24-7.93 bar).**
- **Shirt fabric (100% cotton, blends, etc.).**
- **Fabric thickness and weight.**
- **Moisture retention in shirts should be 40% to 50%.**

The sequence begins by removing a shirt from the damp box and dressing it on the collar and cuff press. As this shirt progresses COUNTERCLOCKWISE through the station, other shirts will also be introduced until there is a shirt at the collar post, the CSBBYMV and the CUCC. The operator will then move in a CLOCKWISE direction to keep shirts in all three operations simultaneously.

The operation sequence for the CSBBYMV is:

1. Load shirt 1 from damp box onto CUCC.
2. Unload CUCC. Hang shirt 1 on garment hook.
3. Load shirt 2 from damp box onto CUCC.
4. Load shirt 1 from garment hook onto buck.

5. Unload CUCC. Hang shirt 2 on garment hook.
6. Load shirt 3 from damp box onto CUCC.
7. Remove shirt 1 from buck. Place on collar post. Form collar and button. Leave shirt on collar post to cure.
8. Load shirt 2 from garment hook onto buck.
9. Unload CUCC. Hang shirt 3 on garment hook.
10. Load shirt 4 from damp box onto CUCC.
11. Hang shirt 1 from collar post on finished rack.
12. Unload shirt 2 from buck. Place on collar post.

Repeat steps 7 through 12.

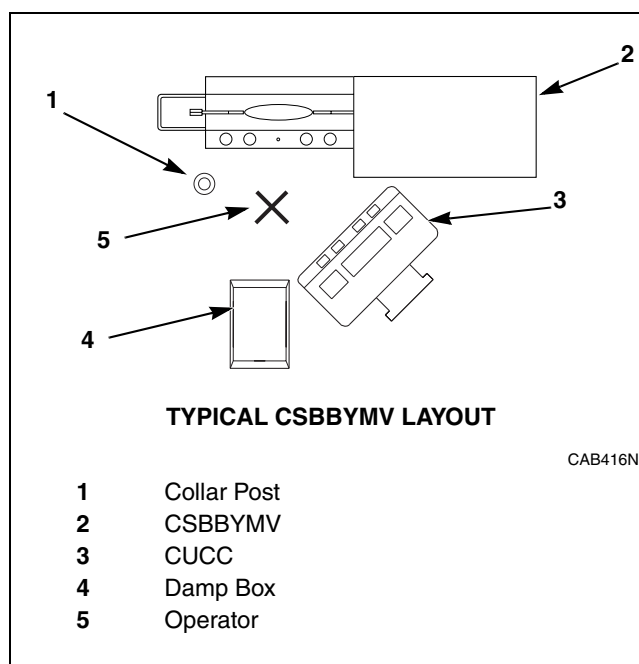

Figure 4

## Operation

### Buck Dressing Instructions

The steps listed below outline the procedure for dressing a shirt on the buck.

1. Grasp shirt by neck band with label side facing you. Turn to buck and swing the right arm of shirt over the buck (at the same time you are guiding the left side so the buck fills shirt armhole). Refer to *Figure 5*.

**NOTE: This action should be as natural as putting on your own shirt. Never lift the shirt over the buck (this would result in unnecessary fatigue).**

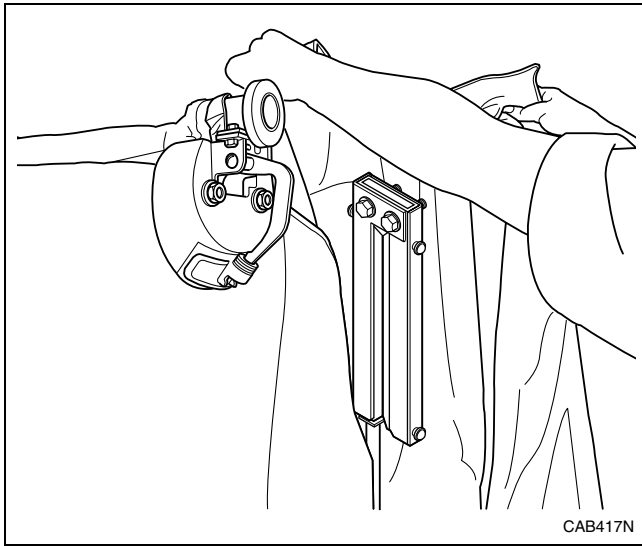

Figure 5

2. Using your right hand, bring the shirt around the buck and let it rest in position. Grasp extreme ends of shirt yoke with both hands. Stretch yoke and center shirt on the buck. Refer to *Figure 6*.
3. Front seam of yoke should form a straight line across the buck when properly dressed.

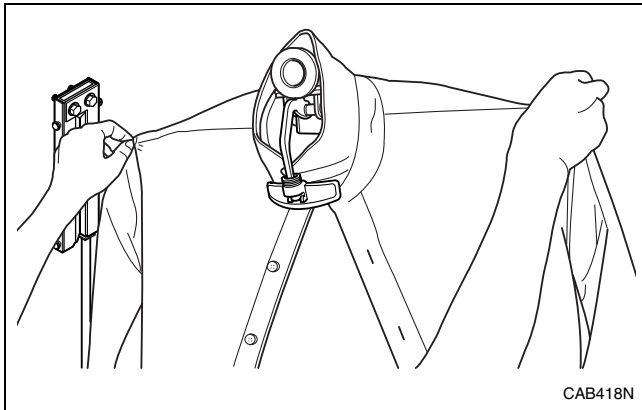

Figure 6

4. Depress collar clamp foot pedal to open collar clamp. Slide index finger of each hand along neck band from the top down to the points of the collar. Guide left collar point under right point. Butt neck band ends together. Do NOT overlap band ends except for large size shirts. Refer to *Figure 7*.
5. Hold neck band ends up in place with two fingers placed just below button and buttonhole of neck band. Release collar clamp foot pedal to close clamp against shirt collar. Buttonhole must be under clamp so that button strip will not distort it when pulled. Refer to *Figure 8*.

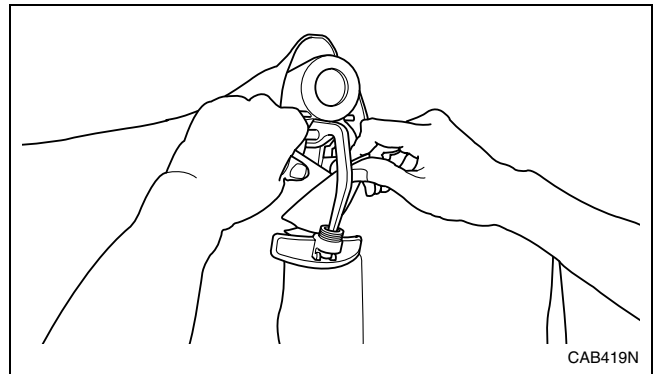

Figure 7

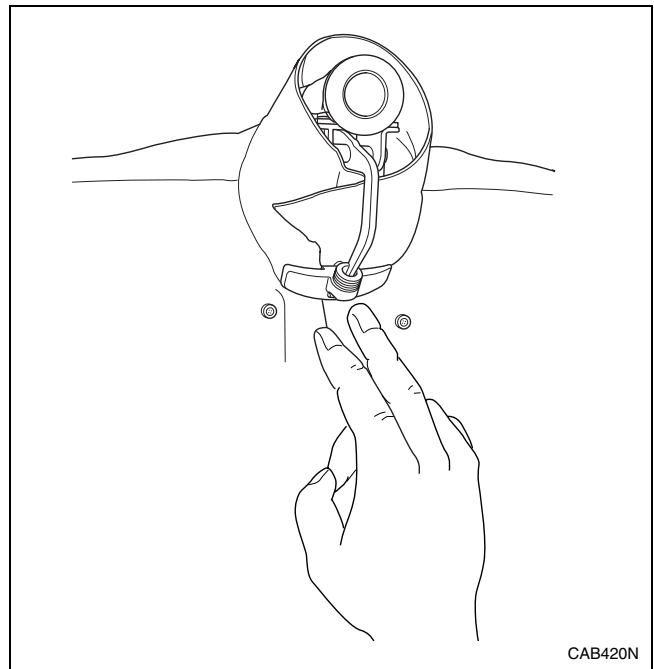

Figure 8



- Grasp one sleeve with gusset facing you. Overlap gusset of cuff as if you are going to button cuff so that air does not escape gusset. The sleeve end is now closed (do not button). Refer to *Figure 9*.

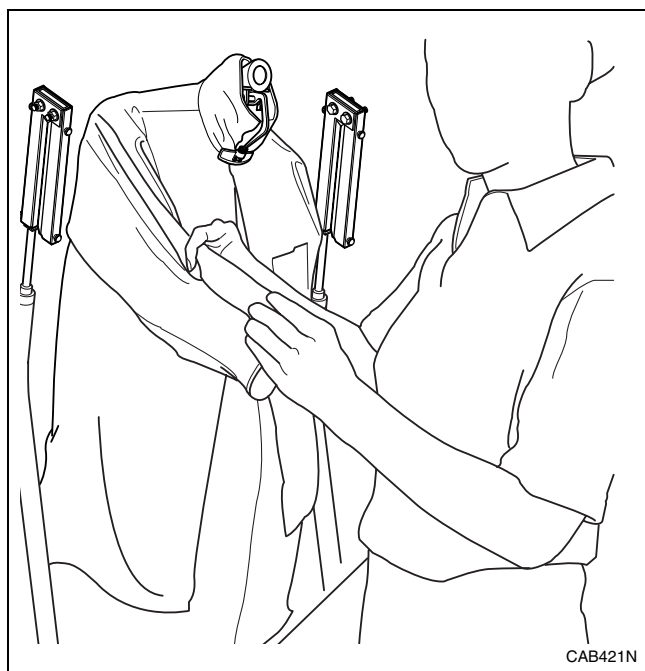

Figure 9

- Turn cuff so gusset is facing away from you. Slide closed sleeve upward in the sleeve extender just above cuff seam. Sleeve should not be twisted between shoulder and cuff. Pleat closest to gusset should ride top edge of sleeve. Repeat with other sleeve. Refer to *NOTE*.

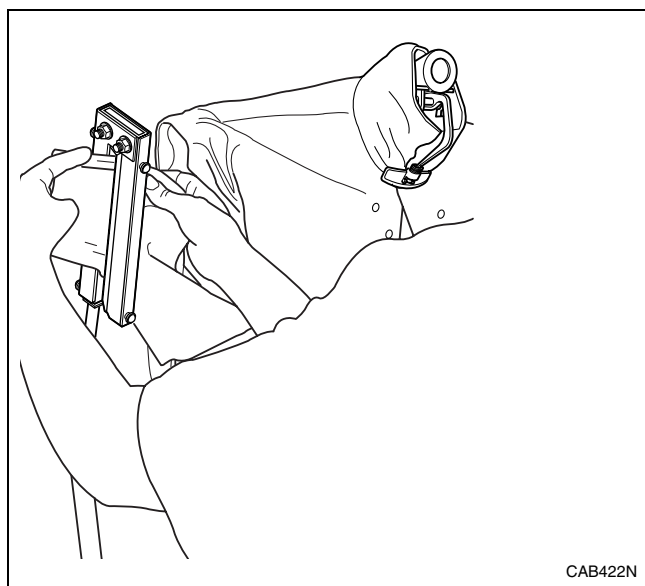

Figure 10

**NOTE: Dress sleeve into clamp at CUFF SEAM. Do NOT place cuff in clamp. Loading cuff into clamp will pinch or crease the cuff. A guide on each clamp will cause you to meet resistance if cuff is accidentally loaded. Refer to *Figure 11*.**

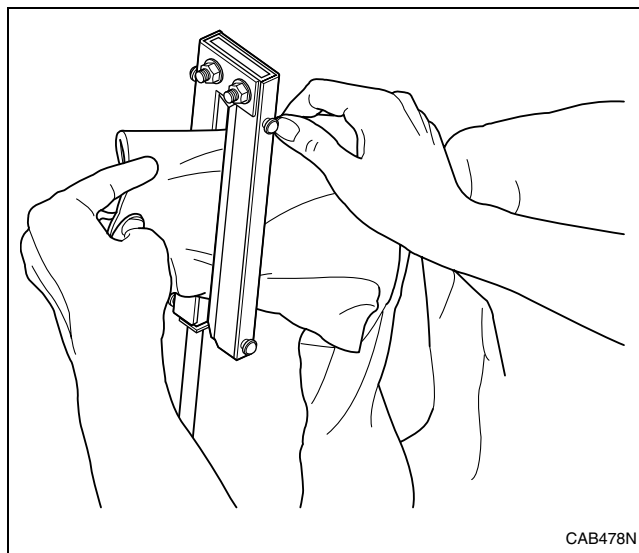

Figure 11

**NOTE: Do NOT leave gap between cuff and clamp when loading sleeve. The area of the sleeve below clamp will NOT finish properly. Refer to *Figure 12*.**

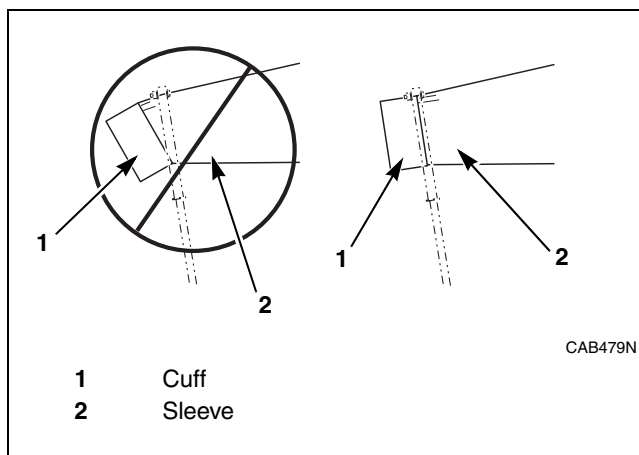

Figure 12

**NOTE: Do NOT clamp short sleeve shirts. Instead, turn STEAM Timer Selector switch to the OFF position when pressing short sleeve shirts. Return STEAM Timer Selector switch to the ON position for long sleeves.**

## Operation

- Press the left foot pedal to extend the sleeves and turn the buck vacuum on.
- Notice a natural "A" at shirt's placket. The gap at the bottom is related to shirt size. The larger shirts will have a smaller gap. Refer to *Figure 13*.

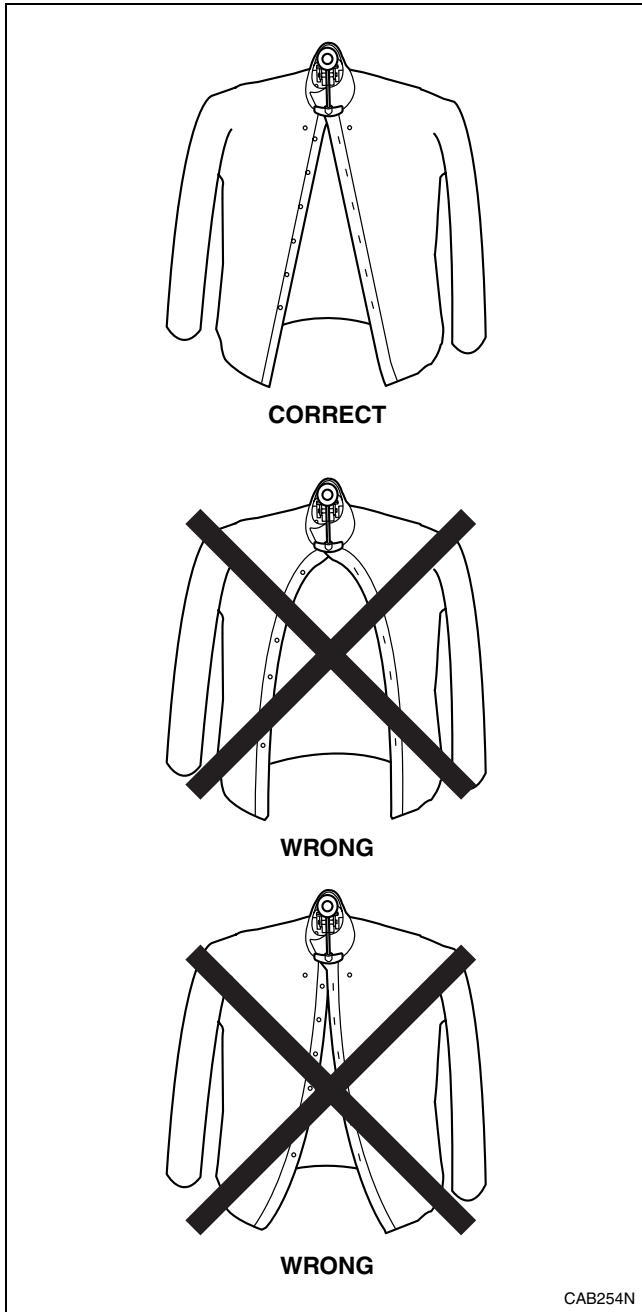

Figure 13

- Using the thumb and first finger of both hands, grasp bottom of placket and side seam on right side of shirt. Gently pull downward. Pull placket downward in the direction of the "A." Refer to *Figure 13*.

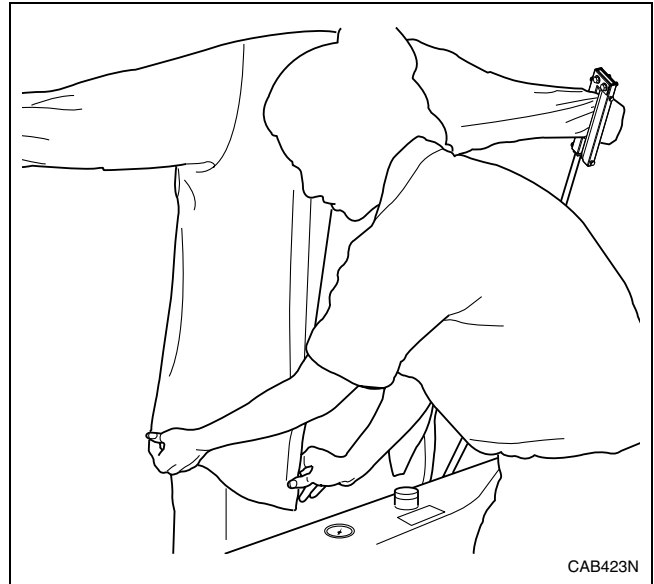

Figure 14

- With thumb and first finger of both hands, grasp the bottom of the placket and side seam at the left side of the shirt. Gently pull downward. Pull the placket downward in the direction of the natural "A." This action has straightened the front and back of the shirt.

**IMPORTANT: Do NOT attempt to fit the shirt to the buck or placket bowing will occur. The side seams of the shirt should roll toward back of buck. Remember, dress the shirt LOOSELY. The air bags will expand to fit the shirt.**

- Look in mirror to check shirt back for horizontal or angled wrinkles from the middle of yoke outward toward the sides. If necessary, gently pull shirt downward in center to remove these wrinkles. Air bags will remove vertical wrinkles when forming shirt.

**NOTE: The front and back of shirt should now be straight.**

13. Spray with water gun if necessary. Refer to *Figure 15*.

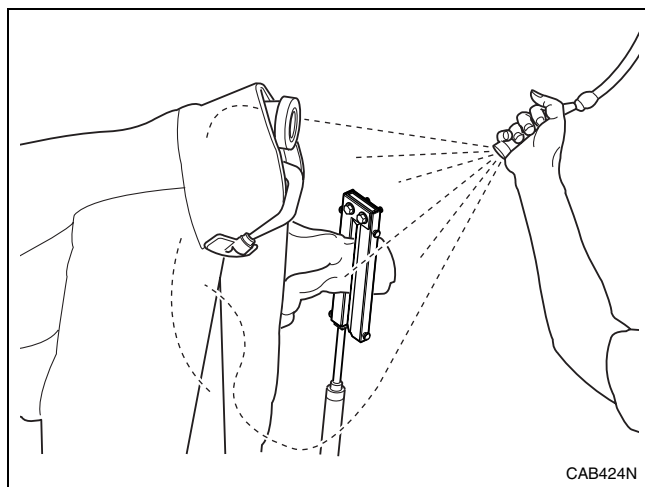

Figure 15

14. If necessary, move your hand in an upward direction over the pocket to remove any air trapped inside. Refer to *Figure 16*.

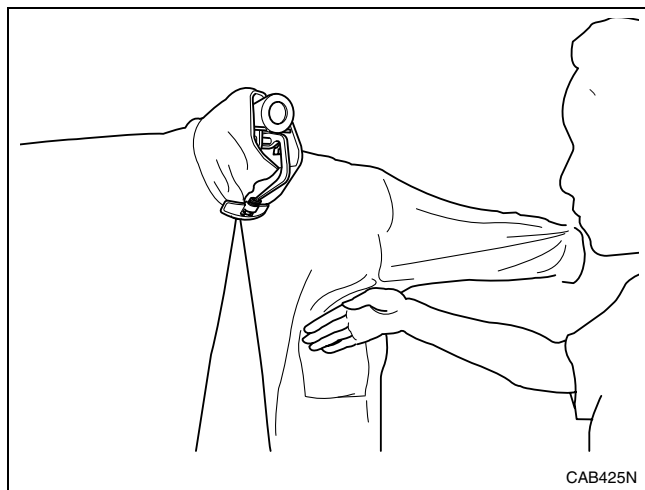

Figure 16

**NOTE: Only excessive wrinkles must be removed by operator.**

15. Press both BUCK IN buttons at the same time to start pressing cycle.

**NOTE: Stay clear as buck enters cabinet.**

16. When press cycle is finished and buck has traveled out of cabinet, unclamp sleeves by pulling both of them down at the same time. Refer to *Figure 17*.



Figure 17

17. Press right foot pedal to release collar clamp. Lift right side of shirt. Move right shoulder clear of buck with a slight upward then backward motion of your hand. Do not swing your right arm over the buck (that would be unnecessary motion). Refer to *Figure 18*.

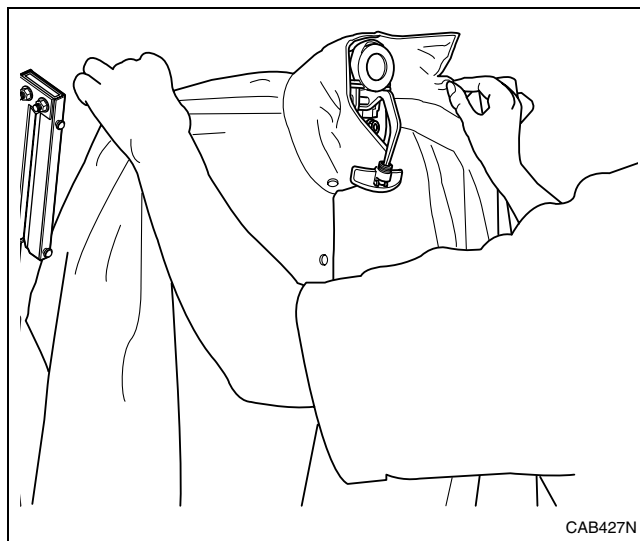

Figure 18

## Operation

- Using your left hand, grasp the left sleeve just next to the yoke. Pull the shirt to your left and off the buck. As the right side of shirt clears the buck, position the fingers of your right hand so they catch the left side of shirt and slide to the right of the yoke. This opens the shirt and supports it so it can easily drape over collar form. Refer to *Figure 19*.



Figure 19

- Grasp center of collar with thumb and finger of both hands just above neck band. Run hands along collar slightly turning the collar back. When fingers reach the end of neck band, hold neck band straight out and completely fold collar over. Continue holding folded collar and polish inside of neck band on collar form. Run the collar from right to left while applying light tension.
- Pull collar toward you. Place collar against collar former and press collar firmly down against heated collar post. Allow collar to cure on post.
- Push sleeve extender release button to bring sleeve rods toward buck for loading next shirt.

## Operating Tips

### Shirt Quality

The CSBBYMV gives a high volume professional finish to sleeves, bosom, body, sides and yoke of shirts. To achieve best shirt quality and volume:

- Extract shirts to obtain 40% to 50% moisture retention.
- Keep press padding in good condition.

Too *much* moisture in shirts will increase pressing cycle time, reduce shirt production and padding life. Too *little* moisture will cause poor shirt finish.

### Checking Moisture Retention in Shirts

Moisture retention is the percentage increase in weight of a load of shirts *after* they are washed and extracted.

To check moisture retention:

- Weigh a load of dry shirts.
- Wash and extract shirts and then weigh them again.

The percentage increase in weight is the moisture retention for that load.

**Example:** A load of shirts weighs 50 pounds (22.68 kg) dry. After being washed and extracted, that same load weighs 70 to 75 pounds (31.75 to 34.02 kg). The difference in weight is 20 to 25 pounds (9.07 to 11.34 kg). The percentage of added weight is the difference over the dry weight or 20/50 and 25/50 which is 40%/50%.

Extract times required for optimum moisture retention will vary by washer. Always test several loads of shirts when determining extract and conditioning times. Shirt fabric also affects moisture retention. One hundred percent (100%) cotton shirts will hold more moisture than cotton/poly blended shirts.

**NOTE: Do NOT judge moisture by touch. Warm shirts feel dryer than cold shirts.**

### Shirt Quality Troubleshooting

Most quality related problems are due to:

- Worn base pads, padding, and air bags.
- Incorrect dressing techniques (refer to *Operating Instructions*).
- Incorrect moisture retention.
- Improper steam pressure.

Refer to *Table 2* for problems and recommended solutions.

## Padding

Padding is very important to garment quality. Air bags which are worn or made from improper material cannot give good results. Bag and cover assemblies purchased from different suppliers can affect shirt quality.

Thirty ounce (30 oz.) flannel padding (manufactured from reprocessed nylon) is originally provided with the press. It is considered to be the best, most economical padding available. In most cases, this material will give quality performance for a period of 3 to 5 weeks, depending on production, type of garment pressed, moisture retention, and chemical residue in shirts.

**NOTE: Replace worn flannel with thirty ounce (30 oz.) flannel. Fifty ounce (50 oz.) flannel is NOT recommended for vacuum units.**

To increase the life cycle, build up padding that has developed low areas and is producing pin wrinkles or rough dry spots on finished shirts by:

- Cutting pieces of cotton flannel to exact size of depression in padding.
- Feathering edges of the flannel.
- Fitting those pieces under padding in the depressions.

The life cycle of nylon air bags can be extended if sprayed with water and pressed between heads (without a shirt on the buck) three times at every break.

Dressing techniques used by the operator can also produce rapid local wear or permanent distortion of air bags.

**NOTE: An operator that “saws” the collar in dressing a buck will often wear out the yoke bag on each side of collar clamp. If wear of this kind occurs, spraying these local areas with silicone spray is recommended. Silicone spray is available in aerosol cans from most hardware stores.**

## Quality Troubleshooting

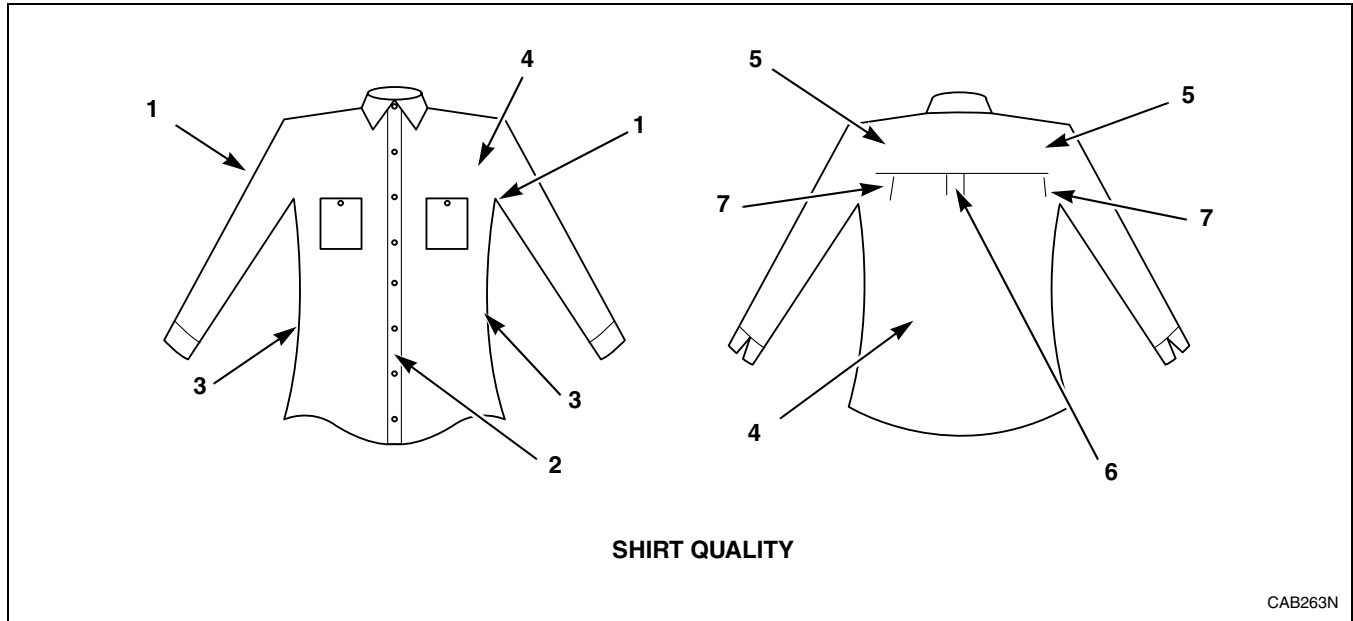

Figure 20

Refer to *Figure 20*.

Trouble	Probable Cause	Solution
Damp patches on sleeve (item 1)	1. Cycle time too short.	Increase Timer.
	2. Boiler pressure too low.	Adjust pressure.
	3. Faulty trap or check valve in steam return line from condensate tank.	Clean, repair or replace faulty trap or check valve.
	4. Steam supply coming from bottom of header, no riser.	Correct inlet piping. Refer to Installation Manual.
Placket bowing at the button strips (item 2)	1. Operator pulling shirt too tightly on buck.	Dress shirt so it hangs in natural "A." Refer to <b><i>Buck Dressing Instructions</i></b> .
	2. Shirt not held in place by vacuum.	Fan or draft in plant blows shirt during transfer. Redirect fan. Close window or door which causes draft. Check for hole or collapsed hoses. Flannel padding is too thick. Install thirty ounce (30 oz.) flannel padding.
	3. Air remains in side air bags at end of pressing cycle and distorts shirts.	Damper to heat exchanger is not closing off or is not closing off soon enough. Adjust as necessary.
	4. Air to side air bags distorts shirt before heads begin to press.	Adjust high pressure air to buck air bags.

Table 2 (Continued)

Table 2 (Continued)

<b>Trouble</b>	<b>Probable Cause</b>	<b>Solution</b>
Rough dry damp patches on sides (item 3)	1. Pressing cycle too short.	Increase pressing time.
	2. Shirt moisture retention is over 50%.	Reduce moisture retention by increasing extract time or speed or by increasing water temperature of final rinse.
	3. Shirt moisture retention is under 40%.	Increase moisture retention by decreasing extract time or speed or by decreasing water temperature.
	4. Improper air bags installed on buck.	Check air pressure gauge on discharge tube when buck is in pressing position and blower is on. If air pressure gauge does not read between .7 and 1 psi, replace air bag using the recommended vendor list in your Preventative Maintenance Guide.
	5. Operator is over-spraying garment.	Instruct operator to use less water spray.
	6. Insufficient temperature at heat exchanger.	Either heat exchanger trap or check valve is faulty and needs repair or replacement; or steam pressure to press is lower than 115 psi (7.92 bar).
	7. Collapsed hoses in blower air system.	Check ALL hoses in blower air system. Check for collapsed inner wall by removing hose from machine. Straighten hose and look through hose from one end to the other.
	8. Air leak at discharge tube.	Align discharge tube to meet up with receiving tube.
	9. Holes in side air bags.	Replace air bags.
Damp patches on front or back of garment, OR pin wrinkles or rough dry spots around front button strip (items 2 and 4)	1. Pressing cycle too short.	Increase pressing time.
	2. Shirt moisture retention is over 50%.	Reduce moisture retention by increasing extract time or speed or by increasing water temperature of final rinse.
	3. Shirt moisture retention is under 40%.	Increase moisture retention by decreasing extract time or speed or by decreasing water temperature.
	4. Operator is over-spraying garment.	Instruct operator to lessen water spray.
	5. Insufficient temperature at either front or rear press head.	Check traps and check valves in steam return for proper operation. Clean, repair or replace as required. Steam pressure to press should be 115 psi (7.92 bar).
	6. Air pressure is low.	Provide 65 psi (4.48 bar) air inlet pressure.
	7. Padding has sunken areas or is worn and must be replaced.	Replace flannel and/or steel padding.
Rough, dry in yoke area (item 5)	1. Same as Probable Causes 1 through 6 on item 3.	Take corrective action.
	2. Electric thermostat is set below 350°F (178°C).	Set thermostat at 350°F (178°C).
	3. Electric heater element or thermostat is malfunctioning.	Refer to <i>Service Manual</i> or contact a qualified service technician.

Table 2 (Continued)

## Operation

Table 2 (Continued)

Trouble	Probable Cause	Solution
Middle pleat is too long (extends down entire back of shirt) (item 6)	1. Holes in air bag do not allow air bags to fill out shirt.	Replace bag and cover assembly on buck.
	2. Collapsed hoses in blower system restrict airflow to air bags.	Check ALL hoses in blower air system. Check for collapsed inner wall by removing hose from machine. Straighten hose and look through hose from one end to another.
	3. Improper air bags installed on buck.	Check air pressure gauge on discharge tube when buck is in pressing position and blower is on. If air pressure gauge does not read between .7 and 1 psi, replace air bag using the recommended vendor list in your Preventative Maintenance Guide.
Shirt side pleat is distorted or crease is pressed into shirt (item 7)	1. Yoke bag is not providing proper lift.	Check where yoke bag is sewn into cover. It should extend 1/2 in. (12.7 mm) beyond cover on either side.
	2. Operator is pulling a twist into back of shirt.	Have operator use mirror and make one slight tug in middle of shirt toward the bottom area.



# Maintenance

## General

This section contains information and instructions required to perform periodic inspections and lubricate the press.

Shutdowns due to unscheduled maintenance can be avoided or minimized by:

- performing periodic inspections as described and
- performing lubrication services at the time intervals specified in these instructions.

The following are recommended precautions that service personnel must understand and apply when performing general periodic maintenance tasks.

	<b>WARNING</b>
<p><b>To avoid possible serious injury:</b></p> <ul style="list-style-type: none"><li>• <b>ALWAYS</b> shut off services to press <b>BEFORE</b> removing guards and covers to do <b>ANY</b> maintenance, service, set-up, adjustments or repair tasks.</li><li>• Shut off <b>AND</b> lock out <b>ALL</b> electric power to press.</li><li>• Shut off <b>AND</b> lock out <b>ALL</b> air service to press.</li><li>• Shut off <b>AND</b> lock out <b>ALL</b> steam service to press.</li><li>• Let heated surfaces cool.</li><li>• Be sure moving parts are at a standstill.</li><li>• <b>ALWAYS</b> be careful to <b>AVOID</b> spring loaded components when working inside press.</li><li>• <b>NEVER</b> adjust, clean or dress buck while indexing press.</li><li>• <b>ALL</b> maintenance, services, etc., <b>MUST</b> be performed <b>ONLY</b> by qualified service personnel.</li></ul>	
W379	

	<b>WARNING</b>
<p><b>To avoid possible serious injury ALWAYS close air supply line shut-off valve AND lock out air service BEFORE:</b></p> <ul style="list-style-type: none"><li>• opening filter drain cock</li><li>• removing filter bowl</li><li>• filling oil bowl</li></ul>	
W380	

## Periodic Inspections

The frequency at which inspections should be performed, the inspection procedures to be followed, and the corrective actions to take are listed in *Table 3*. If complete details for the inspections and/or corrective actions are not listed in *Table 3*, refer to the referenced paragraphs for detailed instructions.

## Maintenance

### Periodic Inspections

Timer Intervals	Operation or Inspection	Corrective Action
Daily or as required	Visually inspect the air intake filters.	Replace when dirty. They are throwaway-type filters but can be cleaned once before discarding.
	Visually inspect intake air screen.	Remove lint from screen.
	<b>NOTE: Do not operate blowers unless air filters are installed.</b>	
	Visually inspect the sight glass in the air line filter at the inlet.	If moisture and oil are collecting in the bowl, the auto-drain is not working. Clean, repair or replace air filter.
	Visually check the discharge tube gasket.	Replace worn or missing gasket.
	<b>NOTE: DO NOT operate press if discharge tube gasket is missing.</b>	
Weekly	Inspect air line filter for sediment.	Clean as necessary.
	Inspect all safety labels. See Parts Manual for location and description of labels.	Replace labels which are damaged, missing or unreadable.
	Inspect buck stop adjustments. Shock absorber should not bottom out.	Adjust shock or bumper as required.
Every 2 weeks	Inspect steam strainers in steam inlet and outlet lines and in traps.	Clean strainers and traps.
	Inspect each blower motor intake for lint build-up.	Remove lint from motor.
	Inspect customer-furnished steam traps per instructions provided with traps.	Clean as necessary.
Monthly	Check all steam and air connections for visual signs of leakage.	Tighten any loose connections. Replace lines where necessary.
	Check condition of the flexible steam hoses.	Steam hoses with broken braids must be replaced.
	Attempt to rock buck at operator station back and forth; check rollers against rails.	If buck carriage rollers are loose against rails, tighten as required. Rollers should be snug, but not too tight.
Every 6 months	Remove all covers and check cap screws, fittings and cylinders for security of attachments.	Tighten as required.

Table 3

## Cleaning Air Filter

Air filters remove foreign matter and condensate from supply air as it passes through filter. The frequency at which the filter baffle plate and filter element should be cleaned depends upon the amount of condensate and foreign matter in the supply air. The condensate level should not raise above the baffle. That is a sign of a faulty auto-drain which would need to be cleaned, replaced or repaired.

Erratic regulator operations or loss of regulation is almost always due to dirt.

The following steps outline the procedure for cleaning the air filter.

	<b>WARNING</b>
<p><b>To avoid possible serious injury ALWAYS close air supply line shut-off valve AND lock out air service BEFORE:</b></p> <ul style="list-style-type: none"> <li>• opening filter drain cock</li> <li>• removing filter bowl</li> <li>• filling oil bowl</li> </ul> <p style="text-align: right;">W380</p>	

1. Close and lock air service shut-off valve.
2. Remove filter bowl. Use a strap wrench if required. Disassemble regulator, making notes as a guide for reassembly.
3. Clean parts with household soap and blow out body with compressed air.

**IMPORTANT: DO NOT use cleansing agents such as acetone, benzene, carbon tetrachloride, gasoline, toluene, etc., which are damaging to the plastic sight glass.**

4. Reassemble per your notes. Make sure o-ring is in position on the filter bowl. Tighten bowl to filter body. Tighten slightly more than hand tight.
5. Open air service shut-off valve.

Maintenance kits available. Refer to parts manual for numbers.

## Cleaning Steam Strainer

Strainer removes foreign matter from steam. The frequency at which the strainer must be cleaned is dependent upon the amount of foreign matter suspended in the steam. It is recommended that the strainer screen be removed and checked for cleanliness after 2 weeks or 80 hours of operation. If little or no foreign matter has collected on the screen, time between inspections can be increased accordingly.

	<b>WARNING</b>
<p><b>To avoid possible serious injury when cleaning or repairing traps or strainers:</b></p> <ul style="list-style-type: none"> <li>• Shut off AND lock out ALL steam service to press.</li> <li>• Let heated surfaces cool.</li> </ul> <p style="text-align: right;">W381</p>	

## Cleaning Customer-Furnished Steam Traps

Some steam traps are provided with internal steam strainers. These strainers should be cleaned.

All repairable traps should be opened at least once a year to visually check operating mechanisms.

Remove sediment and dirt from trap body. The mechanism may require cleaning by immersing in appropriate cleaning fluid.

**NOTE: Check instructions provided with trap or with trap manufacturer for appropriate cleaning fluids.**

Lubrication

	<b>WARNING</b>
<p>To avoid possible serious injury:</p> <ul style="list-style-type: none"> <li>• <b>ALWAYS</b> close air supply line shut-off valve <b>AND</b> lock-out air service <b>BEFORE</b> performing lubrication services.</li> </ul>	
W437	

Monthly Lubrication

Refer to *Figure 21*, *Figure 22* and *Table 4* for lubrication points.

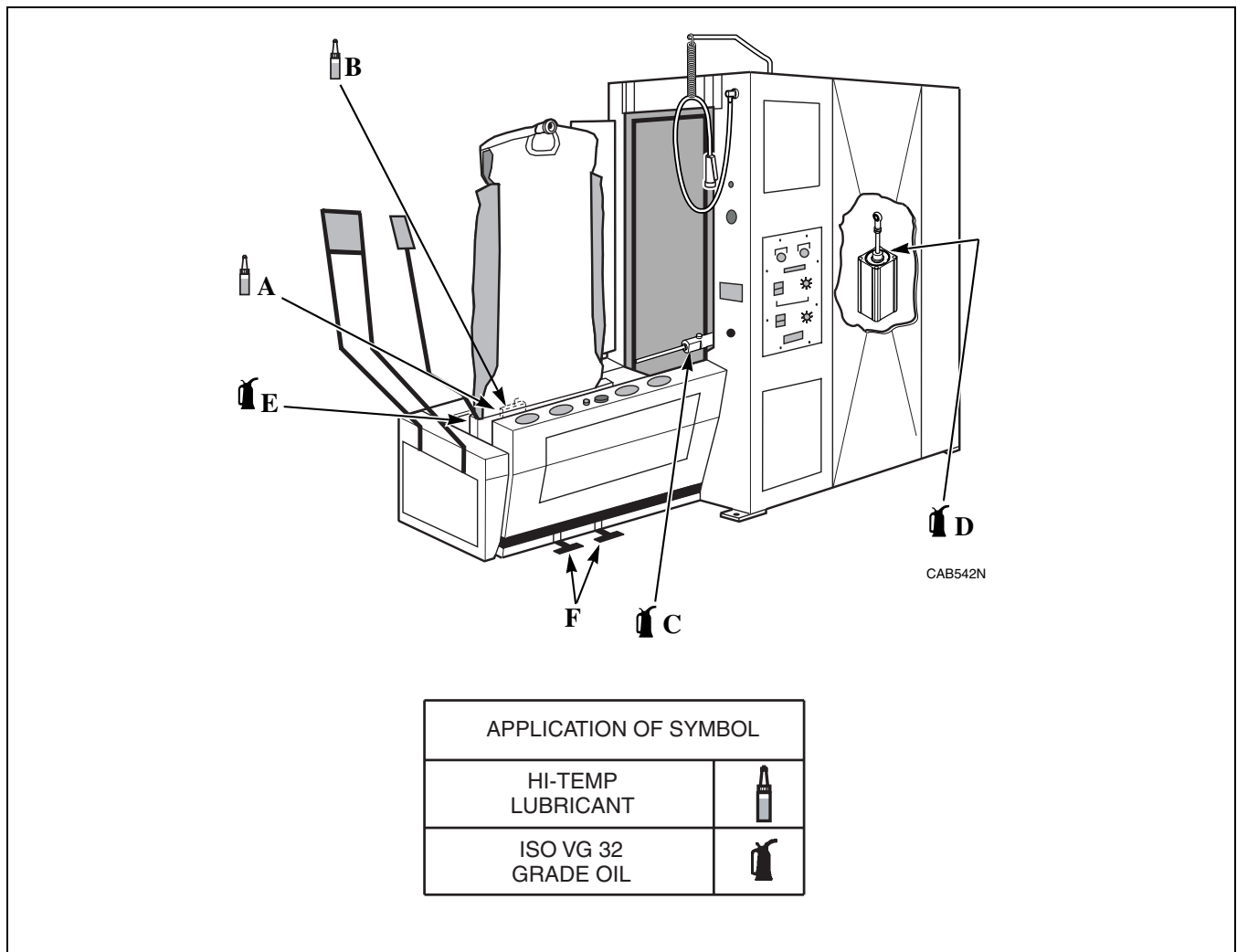

Figure 21

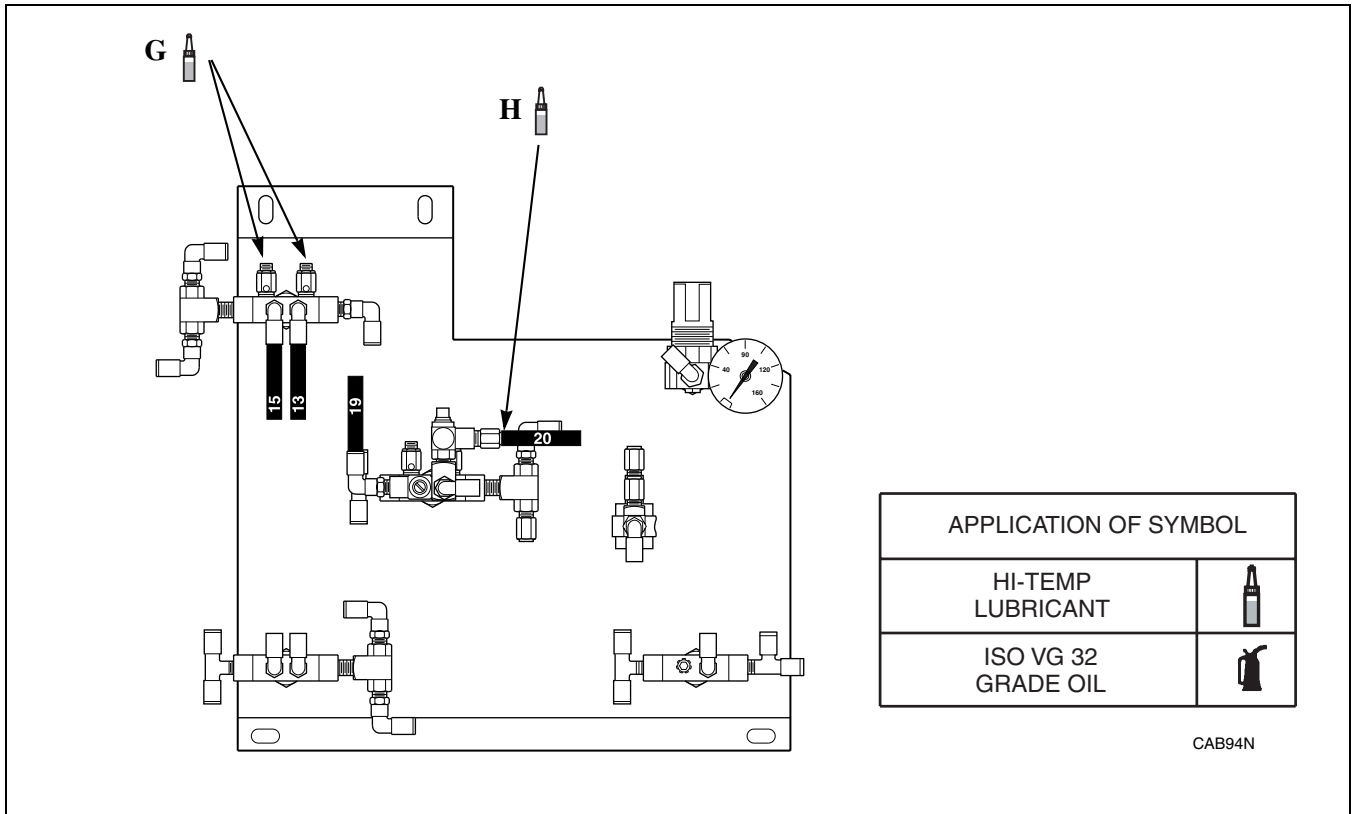

Figure 22

## Maintenance

### Monthly Lubrication

Refer to *Figure 21* and *Figure 22*.

Lubrication Point	Type of Lubricant	Lubrication Service
(A) Sleeve expander rod cylinders	ISO VG 32 grade oil	Disconnect air line from cylinder. Dispense 4 drops of oil into air line. Reconnect air line and actuate cylinder to get oil inside cylinder.
(B) Collar block	Ajax hi-temp lubricant	Disconnect air line from collar block at base of buck. Dispense 4 drops of oil into air line. Reconnect air line and actuate collar block to get oil inside cylinder.
(C) Buck indexing cylinder	ISO VG 32 grade oil	With buck in dressing position, remove air line from shaft end of cylinder and dispense 6 to 8 drops of oil into air line. Reconnect air line and push buck into pressing position. With buck in pressing position, remove air line from tail end of cylinder and dispense 6 to 8 drops of oil into air line. Reconnect air line and pull buck back to dressing position.
(D) Front head closing cylinder	ISO VG 32 grade oil	With blower and timer turned off, and heads open, remove line from bottom (end opposite shaft) of cylinder. Dispense 4 to 6 drops of oil into air line and reconnect air line. Index buck into cabinet and allow heads to close. With heads closed, repeat procedure for air line at shaft end of cylinder. After air line is reconnected, press button to allow heads to open.
(E) Sleeve extender pivot point	ISO VG 32 grade oil	Dispense 4 drops to ensure proper working order.
(F) Foot Pedals	ISO VG 32 grade oil	Oil foot pedal at pivot point.
(G) Buck indexing Valve	ISO VG 32 grade oil	Disconnect air line at the valve. Dispense 6-8 drops of oil into air line. Reconnect air lines.
(H) front head closing valve	ISO VG 32 grade oil	Disconnect air line at the valve. Dispense several drops of oil into air line. Reconnect air line.
<p><b>NOTE: Buna-N seals are used extensively throughout the valves and cylinders in the air circuit downstream from the inline oiler. Oils containing graphite fillers, detergent, etc., and fire-resistant and synthetic oils are not compatible with Buna-N seals. Seal swelling and valve malfunctioning will result with use of improper oils.</b></p>		

Table 4

### Adjusting Air Line Lubricator Flow Rate

The air system oil lubricator should be adjusted so approximately one drop of oil every ten machine cycles is metered into the air system. The following steps outline the procedure for adjusting the air system oil lubricator:

1. To initially adjust flow rate, turn on air and cycle press. Set knob to obtain desired flow rate. After system reaches normal operating temperature, check drip rate again and adjust as required.
2. To increase flow rate, use a screwdriver to turn the adjusting screw no more than a 1/8 turn in the counterclockwise direction. Likewise, turn clockwise to decrease oil flow. Refer to item 1, *Figure 23*.

### Filling Air Line Lubricator

**IMPORTANT:** To avoid o-ring leaks at the top of the bowl, do not remove bowl. Fill through the oil fill hole. Refer to item 2, *Figure 23*.

When oil level falls below 1/4 full, refill the bowl to 3/4 full (oil level approximately 1/2 inch [12.7 mm] from top) with SAE 10 weight non detergent oil (refer to ).

	<b>WARNING</b>
<p>To avoid possible serious injury, ALWAYS close air supply line shut-off valve AND lock out air service BEFORE filling oil bowl.</p>	
W383	

**IMPORTANT:** Do not overfill bowl. Damage to filter, regulator, valves and cylinders will result and void warranty.

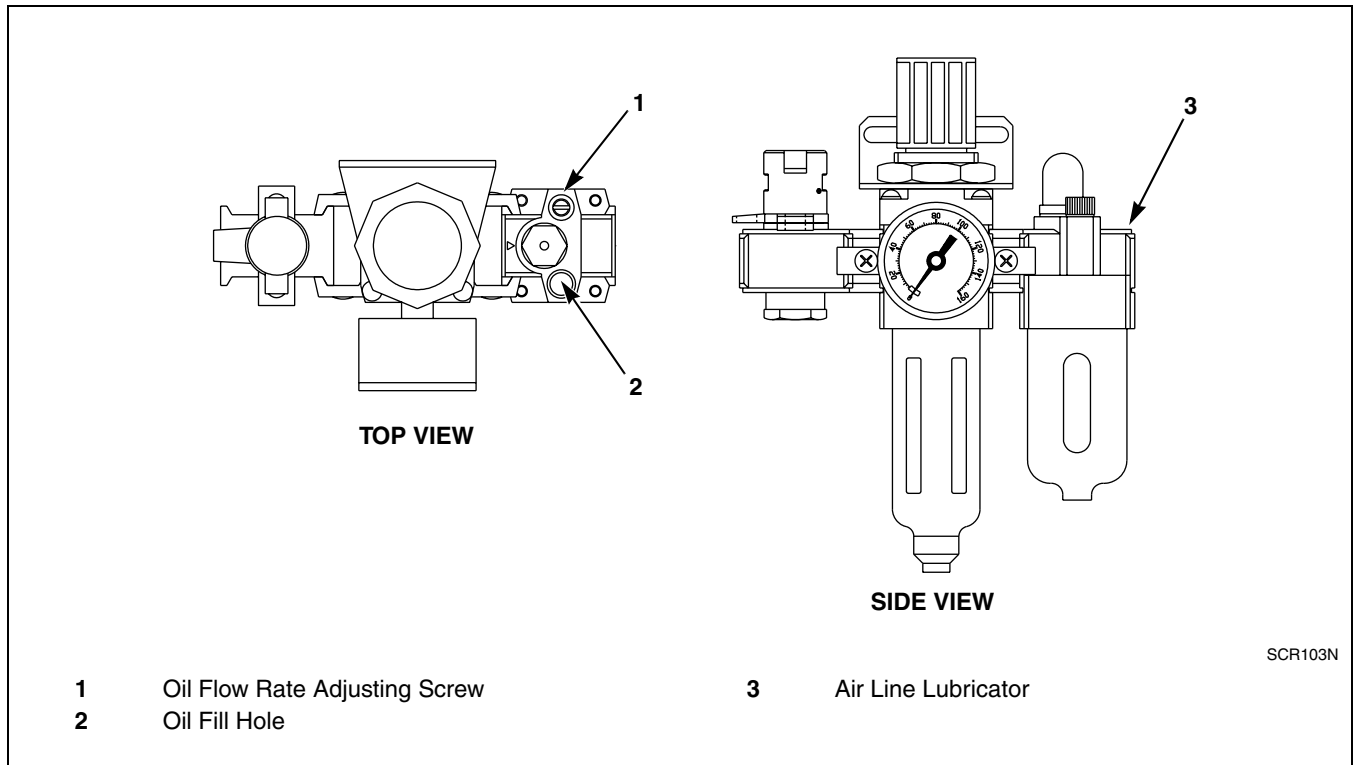

Figure 23





## Free Manuals Download Website

<http://myh66.com>

<http://usermanuals.us>

<http://www.somanuals.com>

<http://www.4manuals.cc>

<http://www.manual-lib.com>

<http://www.404manual.com>

<http://www.luxmanual.com>

<http://aubethermostatmanual.com>

Golf course search by state

<http://golfingnear.com>

Email search by domain

<http://emailbydomain.com>

Auto manuals search

<http://auto.somanuals.com>

TV manuals search

<http://tv.somanuals.com>