

# ***BROADway***

## *INSTALLATION MANUAL*

---



Part Number: 770-0125-AB  
Product Release: 4.00  
March 2004

---

Copyright© 2004 Carrier Access Corporation. All rights reserved.

The information presented in this manual is subject to change without notice and does not represent a commitment on the part of Carrier Access Corporation. The hardware and software described herein are furnished under a license or non-disclosure agreement. The hardware, software, and manual may be used or copied only in accordance with the terms of this agreement. It is against the law to reproduce, transmit, transcribe, store in a retrieval system, or translate into any medium - electronic, mechanical, magnetic, optical, chemical, manual, or otherwise - any part of this manual or software supplied with **BROAD**way for any purpose other than the purchaser's personal use without the express written permission of Carrier Access Corporation.

**BROAD**way, *solve for x*, and the Carrier Access Logo are registered trademarks of Carrier Access Corporation. All other brand or product names are trademarks or registration trademarks of their respective companies or organizations.

Contact Information:

Carrier Access Corporation  
5395 Pearl Parkway  
Boulder, CO 80301-2490  
Corporate Phone: (800) 495-5455  
Fax: (303) 443-5908  
[www.carrieraccess.com](http://www.carrieraccess.com)

Customer Support Direct: (800) 786-9929  
E-mail: [tech-support@carrieraccess.com](mailto:tech-support@carrieraccess.com)

# PREFACE

---

## Compliance

### *Safety of Information Technology Equipment*

**BROAD**way is safety certified by an independent laboratory and is compliant with the following safety standards:

- UL1950, 3rd Edition
- CSA No. 22.2 / cUL60950, 3rd Edition

### *FCC Requirements, Part 15*

This device complies with Part 15 of the FCC Rules. Operation is subject to the following two conditions:

- This device may not cause harmful interference, and
- This device must accept any interference received, including interference that may cause undesired operation

This equipment has been tested and found to comply with the limits for a Class A digital device pursuant to Part 15 of the Federal Communications Rules. These limits are designed to provide reasonable protection against harmful interference when equipment is operated in a commercial environment. This equipment generates, uses, and can radiate radio frequency energy and, if not installed and used in accordance with the instruction manual, may cause harmful interference to radio communications. Operation of this equipment in a residential area is likely to cause harmful interference, in which case the user will be required to correct the interference at the user's own expense.

---

**NOTE:** Changes or modifications to any unit not expressly approved by the party responsible for compliance may cause damage to the equipment and could void your authority to operate the equipment.

---

## **FCC Requirements, Part 68**

The following instructions are provided to ensure compliance with the Federal Communications Commission (FCC) Rules, Part 68.

1. This equipment complies with Part 68 of the FCC rules. This unit bears a label which contains the FCC registration number. If requested, this information must be provided to the telephone company.
2. This equipment uses the following standard jack types for network connection:

<b>Card Type</b>	<b>Service Type</b>	<b>Framing</b>	<b>Coding</b>	<b>REN/SOC</b>	<b>FIC</b>	<b>Network Jack</b>
NHP160	1.544 Mbps	D4 (superframe)	AMI	6.0N	04DU9-BN	Hardwired
	1.544 Mbps	D4 (superframe)	B8ZS	6.0N	04DU9-DN	Hardwired
	1.544 Mbps	ESF (extended superframe)	AMI	6.0N	04DU9-1KN	Hardwired
	1.544 Mbps	ESF (extended superframe)	B8ZS	6.0N	04DU9-1SN	Hardwired
NIP400	1.544 Mbps	D4 (superframe)	AMI	6.0N	04DU9-BN	Hardwired
	1.544 Mbps	D4 (superframe)	B8ZS	6.0N	04DU9-DN	Hardwired
	1.544 Mbps	ESF (extended superframe)	AMI	6.0N	04DU9-1KN	Hardwired
	1.544 Mbps	ESF (extended superframe)	B8ZS	6.0N	04DU9-1SN	Hardwired

3. This equipment is designed to be connected to the telephone network or premises wiring using cabling that complies with the requirements of FCC Part 68 rules.
4. In the unlikely event that this equipment causes harm to the telephone network, the telephone company can temporarily disconnect your service. The telephone company will try to warn you in advance of any such disconnection, but if advance notice isn't practical, it may disconnect the service first and notify you as soon as possible afterwards. In the event such a disconnection is deemed necessary, you will be advised of your right to file a complaint with the FCC.
5. From time to time, the telephone company may make changes in its facilities, equipment, or operations which could affect the operation of this equipment. If this occurs, the telephone company is required to provide you with advance notice so you can make the modifications necessary to maintain uninterrupted service.
6. Repair service and warranty information can be obtained from:  
Carrier Access Corporation  
5395 Pearl Parkway  
Boulder, CO 80301-2490  
(800) 786-9929 or (303) 442-5455
7. All repairs should be performed by Carrier Access or an authorized agent. It is the responsibility of the users requiring service to report the need for service to Carrier Access or an authorized agent.

### ***Industry Canada ICES-003***

#### **English**

This class A digital apparatus complies with Canadian ICES-003.

#### **French**

Cet appareil numérique de la classe A est conforme à la norme NMB-003 du Canada.

### ***Industry Canada CS-03***

This equipment meets the applicable Industry Canada Terminal Equipment Technical Specifications. This is confirmed by the registration number. The abbreviation, IC, before the registration number signifies that registration was performed based on a Declaration of Conformity indicating that Industry Canada technical specifications were met. It does not imply that Industry Canada approved the equipment.

Before installing this equipment, users should ensure that it is permissible to be connected to the facilities of the local telephone company. The equipment must also be installed using an acceptable method of connection. The customer should be aware that compliance with the above conditions may not prevent degradation of service in some situations.

Repairs to certified equipment should be coordinated by a representative designated by the supplier. Any repairs or alternations made by the user to this equipment, or equipment malfunctions, may give the telecommunications company cause to request the user to disconnect the equipment.

Users should ensure for their own protection that the electrical ground connections of the power utility, telephone lines and internal metallic water pipe system, if present, are connected together. This precaution may be particularly important in rural areas.

---

**CAUTION! USERS SHOULD NOT ATTEMPT TO MAKE SUCH CONNECTIONS THEMSELVES, BUT SHOULD CONTACT THE APPROPRIATE ELECTRIC INSPECTION AUTHORITY, OR ELECTRICIAN, AS APPROPRIATE.**

---

## **Safety Information**

---

**CAUTION!** ALWAYS USE CAUTION WHEN INSTALLING TELEPHONE LINES. READ THE CAUTIONS BELOW FOR DETAILS ON SAFETY GUIDELINES TO PREVENT INJURY.

---

- **Never touch uninsulated telephone wires and terminals** unless the telephone line has been disconnected at the Network Interface (NI) as voltage potentials as high as 300 VAC may be present across the transmit and receive pairs.
- **Only use No. 26 AWG or larger** telecommunication line cord, to reduce the risk of fire.
- **Never install telephone wiring during a lightning storm.**
- **Never install telephone jacks in wet locations** unless the jack is specifically designed for wet locations.
- Refer to the installation section of this manual for a safe and proper installation procedure. All wiring external to this equipment should follow the current provision of the National Electrical Code.

## **Notices**

This manual contains important information and warnings that must be followed to ensure safe operation of the equipment.

---

**DANGER!** A *DANGER* NOTICE INDICATES THE PRESENCE OF A HAZARD THAT CAN OR WILL CAUSE DEATH OR SEVERE PERSONAL INJURY IF THE HAZARD IS NOT AVOIDED.

---

---

**CAUTION!** A *CAUTION* NOTICE INDICATES THE POSSIBILITY OF INTERRUPTING NETWORK SERVICE IF THE HAZARD IS NOT AVOIDED.

---

---

**WARNING!** A *WARNING* NOTICE INDICATES THE POSSIBILITY OF EQUIPMENT DAMAGE IF THE HAZARD IS NOT AVOIDED.

---

---

**NOTE:** A *Note* indicates information to help you understand how to perform a procedure or how the system works. Notes should be read before performing the required action.

---

## **Electrostatic Discharge (ESD) Precautions**

ESD can damage processors, circuit cards, and other electronic components. Always observe the following precautions before installing a system component.

1. Do not remove a component from its protective packaging until ready to install.
2. Wear a wrist grounding strap and attach it to a metal part of the system unit before handling components. If a wrist strap is not available, maintain contact with the system unit throughout any procedure requiring ESD protection.

---

**WARNING!** INTEGRATED CIRCUITS (ICs) ARE EXTREMELY SUSCEPTIBLE TO ELECTROSTATIC DISCHARGE. UNLESS YOU ARE A QUALIFIED SERVICE TECHNICIAN WHO USES TOOLS AND TECHNIQUES THAT CONFORM TO ACCEPTED INDUSTRY PRACTICES, DO NOT HANDLE ICs.

---



The ESD warning label appears on packages and storage bags that contain static-sensitive products and components.

## **Warranty**

Carrier Access warrants to BUYER that Products are free from substantial defect in material and workmanship under normal use given proper installation and maintenance for a period of two (2) years from the date of shipment by Carrier Access. This warranty shall not apply to Products that have been either resold or transferred from BUYER to any other party. Any such transfer shall void the above warranty.

BUYER will promptly notify Carrier Access of any defect in the Product. Carrier Access or its agent will have the right to inspect the Product or workmanship on BUYER's premises. Carrier Access has the option to: (a) repair, replace, or service at its factory or on the premises the Product or workmanship was found to be defective; or (b) credit BUYER for the Product in accordance with Carrier Access' depreciation policy. Refurbished material may be used to repair or replace the Product. Products returned to Carrier Access for repair, replacement, or service will be shipped prepaid to BUYER.

### **Limitation of Warranty & Limitation of Remedies**

Correction of defects by repair, replacement, or service will be at Carrier Access' option and constitute fulfillment of all obligations to BUYER for breach of warranty.

Carrier Access assumes no warranty liability with respect to defects in the Product caused by:

- a. modification, repair, installation, operation, or maintenance of the Product by anyone other than Carrier Access or its agent, except as described in Carrier Access' documentation; or
- b. the negligent or other improper use of the Product; or
- c. handling or transportation after title of the Product passes to BUYER.

Other manufacturer's equipment purchased by Carrier Access and resold to BUYER will be limited to that manufacturer's warranty. Carrier Access assumes no warranty liability for other manufacturer's equipment furnished by BUYER.

BUYER understands and agrees as follows: THE WARRANTIES IN THIS AGREEMENT REPLACE ALL OTHER WARRANTIES, EXPRESSED OR IMPLIED, AND ALL OTHER OBLIGATIONS OR LIABILITIES OF CARRIER ACCESS, INCLUDING ANY WARRANTIES OF MERCHANTABILITY AND FITNESS FOR A PARTICULAR PURPOSE. ALL OTHER WARRANTIES ARE DISCLAIMED AND EXCLUDED BY CARRIER ACCESS.

THE REMEDIES CONTAINED IN THIS AGREEMENT WILL BE THE SOLE AND EXCLUSIVE REMEDIES WHETHER IN CONTRACT, TORT, OR OTHERWISE, AND CARRIER ACCESS WILL NOT BE LIABLE FOR INJURIES OR DAMAGES TO PERSONS OR PROPERTY RESULTING FROM ANY CAUSE WHATSOEVER, WITH THE EXCEPTION OF INJURIES OR DAMAGES CAUSED BY THE GROSS NEGLIGENCE OF CARRIER ACCESS.

THIS LIMITATION APPLIES TO ALL SERVICES, SOFTWARE, AND PRODUCTS DURING AND AFTER THE WARRANTY PERIOD. IN NO EVENT WILL CARRIER ACCESS BE LIABLE FOR ANY SPECIAL, INCIDENTAL, OR CONSEQUENTIAL DAMAGES OR COMMERCIAL LOSSES EVEN IF CARRIER ACCESS HAS BEEN ADVISED THEREOF.

No agent, distributor, or representative is authorized to make any warranties on behalf of Carrier Access or to assume for Carrier Access any other liability in connection with any of Carrier Access' Products, software, or services.

### **Warranty Product Returns**

Before returning any equipment to Carrier Access Corporation, first contact the distributor or dealer from which you purchased the product.

A Return Material Authorization (RMA) number is required for all equipment returned to Carrier Access Corporation. Call Carrier Access Corporation Customer Support at (800) 786-9929 or (303) 442-5455 for RMA number, repair/warranty information and shipping instructions. Be prepared to provide the following information:

- Carrier Access Corporation serial number(s) from the system chassis or circuit card(s)
- Name of distributor or dealer from which you purchased the product
- Description of defect



## **Third-Party Software Notices**

### **Sun Microsystems, Inc., Software Notice**

Use of the Sun Microsystems, Inc., software included in this release is governed by the Sun Microsystems, Inc., terms and conditions stated below:

**Copyright 1994-2004 Sun Microsystems, Inc. All Rights Reserved.**

Redistribution and use in source and binary forms, with or without modification, are permitted provided that the following conditions are met:

- Redistribution of source code must retain the above copyright notice, this list of conditions, and the following disclaimer.
- Redistribution in binary form must reproduce the above copyright notice, this list of conditions, and the following disclaimer in the documentation and/or other materials provided with the distribution.

Neither the name of Sun Microsystems, Inc., or the names of the contributors may be used to endorse or promote products derived from this software without specific prior written permission.

This software is provided "AS IS," without a warranty of any kind. ALL EXPRESS OR IMPLIED CONDITIONS, REPRESENTATIONS AND WARRANTIES, INCLUDING ANY IMPLIED WARRANTY OF MERCHANTABILITY, FITNESS FOR A PARTICULAR PURPOSE OR NON-INFRINGEMENT, ARE HEREBY EXCLUDED. SUN MICROSYSTEMS, INC. ("SUN") AND ITS LICENSORS SHALL NOT BE LIABLE FOR ANY DAMAGES SUFFERED BY LICENSEE AS A RESULT OF USING, MODIFYING OR DISTRIBUTING THIS SOFTWARE OR ITS DERIVATIVES. IN NO EVENT WILL SUN OR ITS LICENSORS BE LIABLE FOR ANY LOST REVENUE, PROFIT OR DATA, OR FOR DIRECT, INDIRECT, SPECIAL, CONSEQUENTIAL, INCIDENTAL OR PUNITIVE DAMAGES, HOWEVER CAUSED AND REGARDLESS OF THE THEORY OF LIABILITY, ARISING OUT OF THE USE OF OR INABILITY TO USE THIS SOFTWARE, EVEN IF SUN HAS BEEN ADVISED OF THE POSSIBILITY OF SUCH DAMAGES.

You acknowledge that this software is not designed, licensed or intended for use in the design, construction, operation or maintenance of any nuclear facility.

**Preface**

*Third-Party Software Notices*

---

# TABLE OF CONTENTS

---

## **Preface**

Compliance .....	iii
Safety Information .....	vi
Notices .....	vi
Electrostatic Discharge (ESD) Precautions .....	vii
Warranty .....	viii
Third-Party Software Notices .....	ix

## **1 Introduction**

Overview .....	1-2
----------------	-----

## **2 Installation**

Overview .....	2-2
Chassis Overview .....	2-2
Mounting the Chassis in a Rack .....	2-4
Cabling Power and Ground .....	2-6
Cabling the Serial Craft Port .....	2-9
Cabling the Ethernet Port .....	2-9
Cabling the Network Synchronization Port .....	2-10
Cabling the Clock Ports on the BITS Chassis .....	2-10
Cabling the Clock Ports on the ITU Chassis .....	2-11
Cabling the Alarm Ports .....	2-11
Alarm Input Sensing .....	2-12
Alarm Output Reporting .....	2-13
Alarm Cut Off (ACO) .....	2-13
Installing the NSP101 Control Card .....	2-13
Installing the NIP400 Line Interface Card .....	2-16
Cabling the NIP400 .....	2-17
NIP400 LED Indicators .....	2-18
Installing the NHP160 Line Interface Card .....	2-19
Cabling and Inserting the NHP160 Line Interface Card .....	2-19
NHP160 LED Indicators .....	2-20
Installing the BSP200 Line Interface Card .....	2-21
Cabling the BSP200 .....	2-22
BSP200 LED Indicators .....	2-22
Installing OSP155/ESP155/BCP155 Line Interface Cards .....	2-24
Cabling the OSP155 and BCP155 .....	2-25
Cabling the ESP155 .....	2-27
OSP155, BCP155, and ESP155 LED Indicators .....	2-27
Attaching the Front Panel .....	2-28

Applying Power to the Chassis . . . . . 2-29  
Maintaining **BROAD**way Hardware . . . . . 2-30  
    Installing New Cards . . . . . 2-30  
    Replacing Failed Cards . . . . . 2-31  
    Maintaining the Fan Tray . . . . . 2-32

### 3 Configuration

Overview . . . . . 3-2  
Assigning an IP Address to the **BROAD**way System . . . . . 3-3  
    Default **BROAD**way IP Address . . . . . 3-3  
    Assigning a Different IP Address . . . . . 3-4  
Management Access to the **BROAD**way System . . . . . 3-7  
    Viewing Serial Craft Port Settings With the GUI . . . . . 3-7  
    Local SCP-1 Serial Craft Port Access . . . . . 3-7  
    Remote Modem SCP-1 Serial Craft Port Access . . . . . 3-7  
    Ethernet Port Command Line Access . . . . . 3-8  
    Ethernet Port Web Browser GUI Access . . . . . 3-8  
Logging In With the Web Browser Interface (GUI) . . . . . 3-9  
Logging In With the Command Line Interface (CLI) . . . . . 3-13  
Setting Up User Accounts . . . . . 3-14  
    User Account Management Using the GUI . . . . . 3-15  
    User Account Management Using TL1 . . . . . 3-16  
Changing Your Password . . . . . 3-18  
    Changing Your Password Using the GUI . . . . . 3-18  
    Changing Your Password Using TL1 . . . . . 3-18  
Setting the System Date and Time . . . . . 3-19  
    Setting the Date and Time Using the GUI . . . . . 3-19  
    Setting the Date and Time Using TL1 . . . . . 3-19  
Setting System Node Parameters . . . . . 3-20  
    Setting System Node Parameters Using the GUI . . . . . 3-20  
    Setting System Node Parameters Using TL1 . . . . . 3-21  
Managing the **BROAD**way Configuration Database . . . . . 3-23  
    Managing the Database Using the GUI . . . . . 3-24  
    Managing the Database Using TL1 . . . . . 3-25  
    Exporting the **BROAD**way Database to a TL1 Script . . . . . 3-26  
    Copying Files Between NSP101 Controllers . . . . . 3-27  
    Re-Starting the **BROAD**way System Using TL1 . . . . . 3-27  
Using FTP with the **BROAD**way System . . . . . 3-28  
Upgrading System Software . . . . . 3-29  
    Rolling Back a Software Update . . . . . 3-32  
    Upgrading the Boot ROM . . . . . 3-32  
    TL1 Software Upgrade Commands . . . . . 3-34

**A** **Ports and Cables**

Overview .....A-2  
SCP-1 and SCP-2 Connector Pinouts .....A-2  
ETH-1 and ETH-2 Connector Pinouts .....A-3  
CKIN-1 and CKIN-2 Connector Pinouts (BITS Only) .....A-4  
NIP400 Connector Pinouts (NIP TX1–RX1, NIP TX2–RX2) .....A-5  
ALARMS Connector Pinouts .....A-7  
NHP160 Connector Pinouts .....A-8

**Index**

## *Table of Contents*

---

# CHAPTER 1

---

## *Introduction*

### **In This Chapter**

- Overview

## Overview

Congratulations on your purchase of the Carrier Access **BROADway** system, a single platform supporting a variety of applications at the edge of the broadband network for electrical and optical, circuit-switched and packet-based networking.

This manual describes what you need to know to install your **BROADway** system hardware and perform the initial configuration. Complete details about how to configure and maintain your **BROADway** system, set up packet services, perform diagnostics, and all TL1 commands are included in the online help system on the **BROADway** software CD.

**BROADway** Release 4.00 includes the following new features:

- **Stacking of **BROADway** Systems (Up to Five Nodes or Systems)**—**BROADway** Release 4.00 supports stacking of **BROADway** chassis, where you can connect up to five systems, or nodes. The stacked systems are connected using the BCP155 cards, and configured using the GUI. Refer to the online help system on the CD.
- **FAC1/FAC2 In-band Loopup Codes**—**BROADway** Release 4.00 supports FAC1/FAC2 in-band loopup codes. There are new parameters in the GUI and the command line interface to support this. Refer to the online help system on the CD.
- **Multi-frame Alignment Support**—**BROADway** Release 4.00 supports multi-frame alignment on T1 and E1 interfaces. There is a new parameter in the GUI and the command line interface to support this. Refer to the online help system on the CD.
- **Additional Options Available With the Ping Command**—In Release 4.00, the ping command supported with the packet services command line interface has been extended to allow you to specify the source IP address, interval between ping packets, number of timeouts on ping responses, and the length of the ping packet. Refer to the online help system on the CD.



# CHAPTER 2

---

## *Installation*

### **In This Chapter**

- Overview
- Chassis Overview
- Mounting the Chassis in a Rack
- Cabling Power and Ground
- Cabling the Serial Craft Port
- Cabling the Ethernet Port
- Cabling the Network Synchronization Port
- Cabling the Alarm Ports
- Installing the NSP101 Control Card
- Installing the NIP400 Line Interface Card
- Installing the NHP160 Line Interface Card
- Installing the BSP200 Line Interface Card
- Installing OSP155/ESP155/BCP155 Line Interface Cards
- Attaching the Front Panel
- Applying Power to the Chassis
- Maintaining BROADway Hardware

## Overview

The **BROAD**way system is composed of a chassis, control cards, and various line interface card options. This chapter provides the following information:

- An overview of each of the two **BROAD**way chassis styles
- How to install the **BROAD**way chassis, system control cards, and line interface hardware
- A guide to cabling the various chassis and line card options
- A description of the LED indicator status for each card
- How to maintain the **BROAD**way system in good working order

**WARNING!** WHEN INSTALLING OR REPLACING **BROAD**WAY HARDWARE, ALWAYS ADHERE TO GOOD PRACTICE WITH RESPECT TO ESD PROCEDURES—USE A REGULARLY AND PROPERLY TESTED GROUNDING STRAP.

## Chassis Overview

There are two versions of the **BROAD**way chassis: BITS and ITU. The only difference between the two chassis is the number and type of the external clock synchronization ports available at the front panel, as shown in the following figure. In all other respects the chassis are equivalent and the same mounting and installation instructions should be used for each.

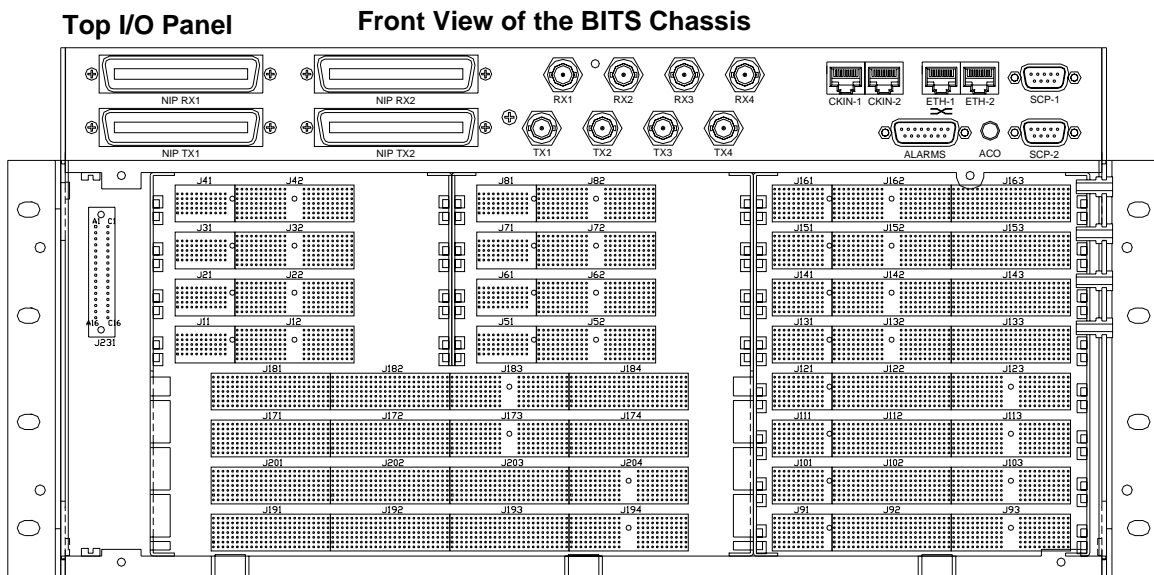

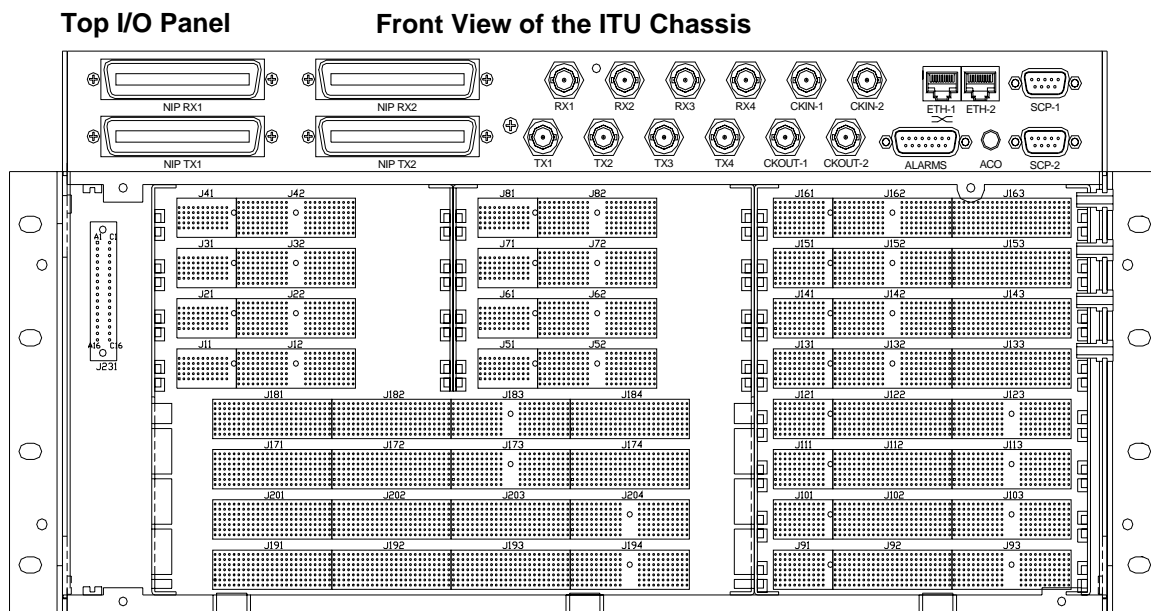

Some line interface cards are cabled directly at the card while others are accessed and cabled through the top I/O panel of the **BROAD**way system.

Each chassis provides the following top I/O front panel connectors:

- **NIP RX1/NIP RX2/NIP TX1/NIP TX2**—50 pin T1/E1 interfaces to the NIP slots
- **RX1/TX1/RX2/TX2/RX3/TX3/RX4/TX4**—75 ohm BNC coaxial interfaces to the BSP slots
- **CKIN-1/CKIN-2/CKOUT-1/CKOUT-2**—(CKOUT on ITU chassis only) Timing interfaces
- **ETH-1/ETH-2**—RJ45 Ethernet interfaces
- **SCP-1/SCP-2**—RS232 serial craft (administration) port interfaces (note that SCP2 is not active in this software release)
- **ALARMS**—Wiring interface for alarm input and outputs

In total, the chassis supports twenty card slots assigned as follows:

- **NSP-1**—The primary slot for the NSP101 system control card
- **NSP-2**—The secondary (backup) slot for the NSP101 system control card
- **NIP-1/NIP-2/NIP-3/NIP-4/NIP-5/NIP-6/NIP-7/NIP-8**—For the NIP400 Quad T1/E1 interface cards
- **UIP-1/UIP-2**—Universal interface card slots for the NHP160 16-port T1/E1 interface cards
- **BSP-1/BSP-2/BSP-3/BSP-4**—For BSP200 DS3 interface cards
- **OSP-1/OSP-2/OSP-3/OSP-4**—For OSP155/ESP155 and BCP155 interface cards

## Installation

### Mounting the Chassis in a Rack

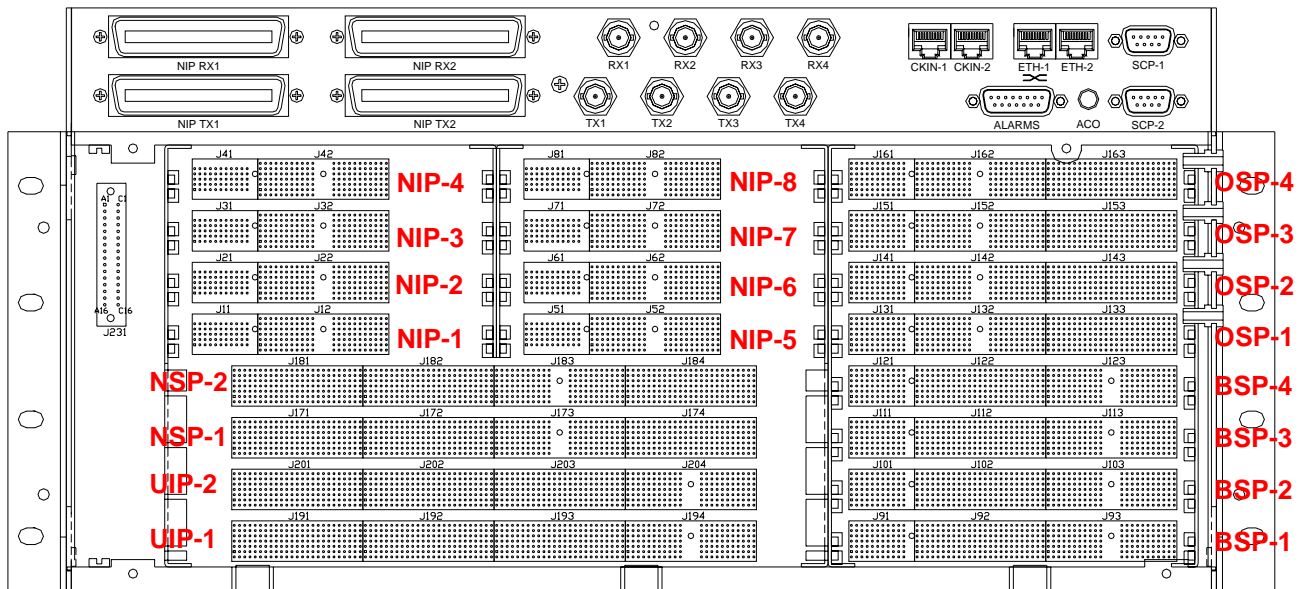

All configurable items in the **BROADway** chassis are managed through the software interface. The backplane of the **BROADway** chassis is keyed to prevent you from inserting a card in the incorrect slot. All **BROADway** control and line cards are hot-swappable, you can insert cards into systems that are either not powered, or systems that are powered.

## Mounting the Chassis in a Rack

Typically, the **BROADway** chassis will be mounted within a rack or bay. The **BROADway** chassis can be installed in either a standard 19- or 23-inch rack. A mounting kit included with the chassis provides the means to support installation in both types of rack.

**WARNING!** WHEN INSTALLING THE CHASSIS IN A RACK, BE CAREFUL TO TRY TO MINIMIZE THE AMOUNT OF BLOCKAGE OVER THE AIR INTAKE AND EXTRACTION PANELS TO THE LEFT AND RIGHT OF THE CHASSIS.

As when installing any additional equipment within an existing or planned rack environment, consider how powering the **BROADway** chassis will impact the overall loading of the branch circuit used at the rack. A fully loaded **BROADway** chassis requires approximately 160W to power the system. When installing in a rack, make sure that a reliable ground (earth) path is maintained; the **BROADway** chassis is intended to be connected to a good earth ground.

The **BROAD**way chassis can be installed within a rack in two different ways:

- **Front-mounted (flush with the front of the rack)**—This is the most commonly used mounting option when the rack is sturdily mounted to a wall.
- **Center of gravity mounted (mid-mounted)**—This mounting option is used when the rack is not sturdily constructed or only attached at the floor. This mounting option centers the chassis over the rails so there is less chance for the rack to tip. This is the most commonly used mounting option.

When determining which way you want to mount the chassis, use the option that will keep the rack stable and unlikely to tip over.

To prevent potential damage to interface and control cards, wait until the chassis is properly mounted before installing any control or line card options.

---

**NOTE:** It is recommended that you leave 1 rack unit (RU) of space above and below the **BROAD**way chassis within the rack for ease of accessibility.

---

To mount the chassis:

1. Determine whether your rack is a 19- or 23-inch rack.
2. Determine how you want to mount the chassis: front-mounted or center of gravity mounted. If you want to mount using the center of gravity position, you must move the mounting ear on each side of the chassis as shown in the following figure:
  - a. Unscrew the four screws holding the mounting ear on one side of the chassis, rotate the mounting ear 180°, move the mounting ear to the next set of holes, and re-insert the four screws.
  - b. Repeat on the other side of the chassis.

**Side View of the Chassis**

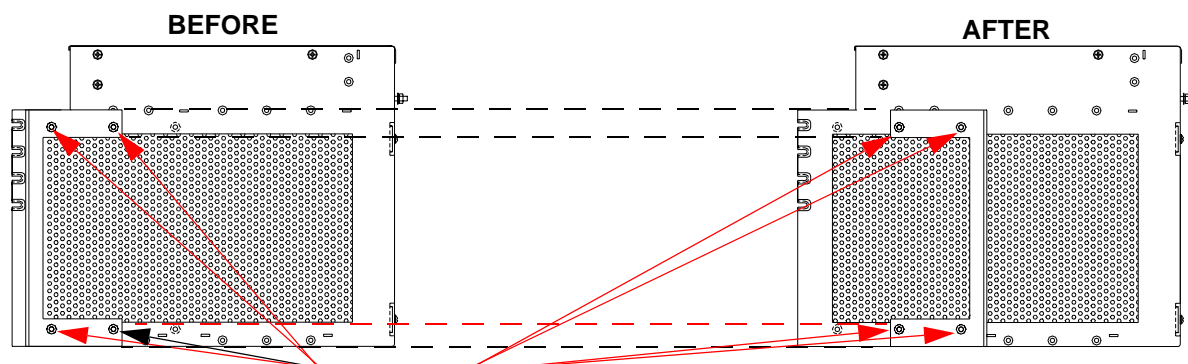

**For mid-mount, unscrew four screws and move mounting bracket on each side**

## Installation

### Cabling Power and Ground

---

3. If you are mounting the chassis in a 23-inch rack, use the four screws that come with each extension bracket (provided with the chassis) to attach the brackets to the mounting ears.
4. Attach the chassis to the rack by inserting four screws on each side of the chassis through both the mounting ears or extensions on the side of the chassis and the rack rails.

Extension Plate

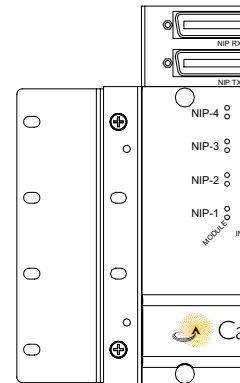

## Cabling Power and Ground

The **BROAD**way chassis accepts a DC power feed directly into the chassis.

---

**NOTE:** To power the **BROAD**way system from an AC supply (110–230 VAC), you must use an external AC-to-DC converter.

---

As when installing any additional equipment within an existing or planned rack environment, consider how powering the **BROAD**way chassis will impact the overall loading of the branch circuit used at the rack. A fully loaded **BROAD**way chassis requires approximately 160W to power the system. When installing in a rack, make sure that a reliable ground (earth) path is maintained; the **BROAD**way chassis is intended to be connected to a good Earth ground such as that provided by building steel, a cold water pipe or, preferably, a properly constructed ground plate or bonding network.

To connect power and ground to the **BROAD**way chassis:

1. Verify that the ON/OFF (**O/I**) switch on the back of the chassis is set to OFF (**O**).
2. Connect the Earth ground stud on the back of the chassis to a suitable Earth ground as previously described.

3. On the back of the chassis are two separate DC feeds (**FEED A** and **FEED B**).

**BROADway Chassis Rear Panel View**

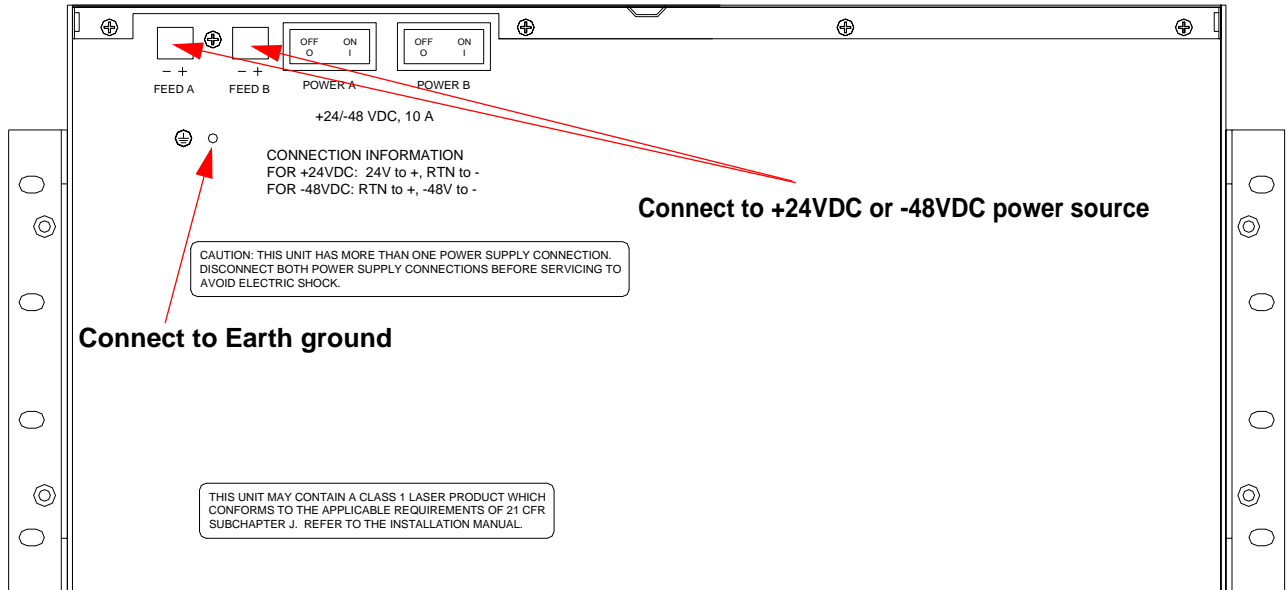

Remove the green connector from the **FEED A** plug.

4. Attach the appropriate leads to the connector. Your power wires will originate from your DC power source.

How you attach the leads varies based on whether you are using a -48 V DC ground referenced power source, or a +24 V DC ground referenced power source.

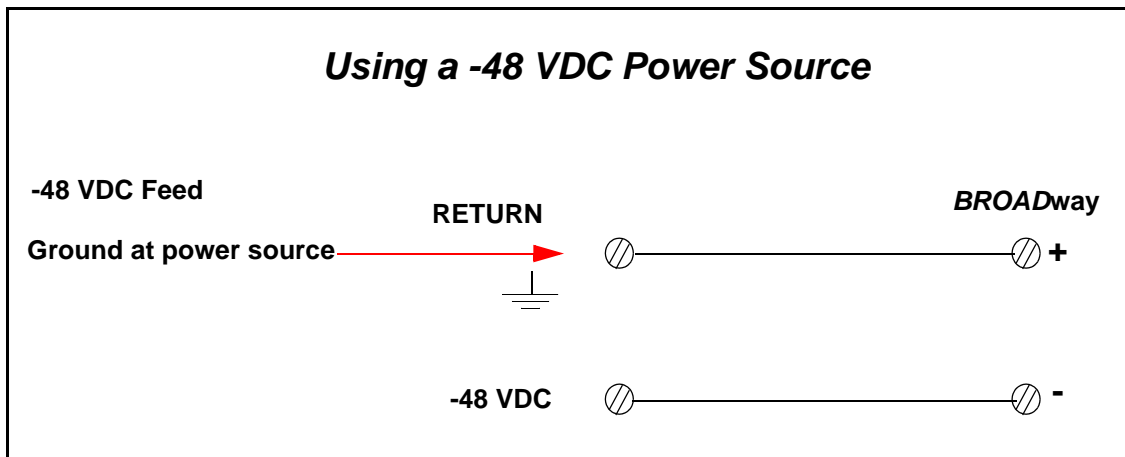

## Installation

### Cabling Power and Ground

---

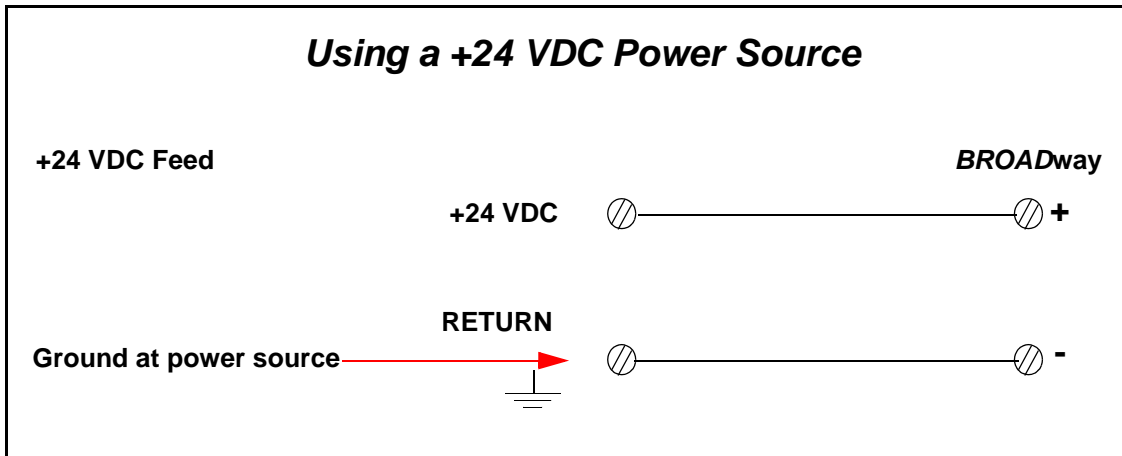

---

**WARNING!** THE **BROADway** CHASSIS DOES NOT PROVIDE AUTOMATIC POLARITY CORRECTION. THAT IS, IF YOU ATTACH THE SUPPLY WIRES IN THE WRONG ORDER, THE INPUT POWER FUSE WILL BLOW. SPARE FUSES ARE ENCLOSED WITH EACH **BROADway** CHASSIS TO HANDLE THIS SITUATION.

---

5. After wiring the green **FEED A** connector, reconnect it to the back of the **BROADway** chassis.
  6. For power redundancy, use an alternate DC power source, and wire **FEED B** in the same manner as **FEED A**.
- 

**DANGER!** THIS CHASSIS HAS TWO POWER SUPPLY CONNECTIONS. DISCONNECT BOTH BEFORE SERVICING TO AVOID ELECTRIC SHOCK.

---



## Cabling the Serial Craft Port

On the top I/O panel of the **BROADway** chassis there are two serial ports: **SCP-1** and **SCP-2**. These serial ports are used for craft access and will support a local or modem attached command line interface. You can use **SCP-1** for direct access using a terminal emulation program, such as HyperTerminal; **SCP-2** is for future use. Use the null-modem serial cable provided with the **BROADway** chassis to connect **SCP-1** to the serial port (**COM1** or **COM2**) of a PC.

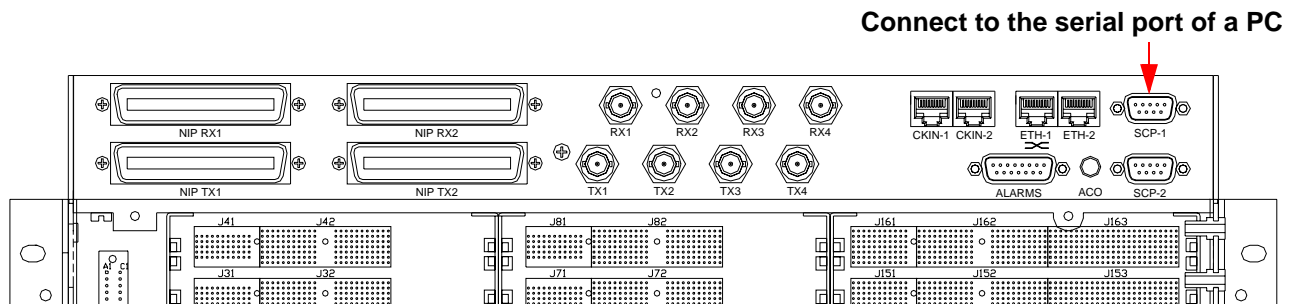

**SCP-1** and **SCP-2** are male, DB9 connectors. For pinout information related to **SCP-1** and **SCP-2**, see *SCP-1 and SCP-2 Connector Pinouts* on page A-2.

## Cabling the Ethernet Port

The **BROADway** management interface can also be accessed through the two 10/100 Ethernet ports at the front of the chassis: **ETH-1** and **ETH-2** can be used for IP/Ethernet access to the **BROADway** system.

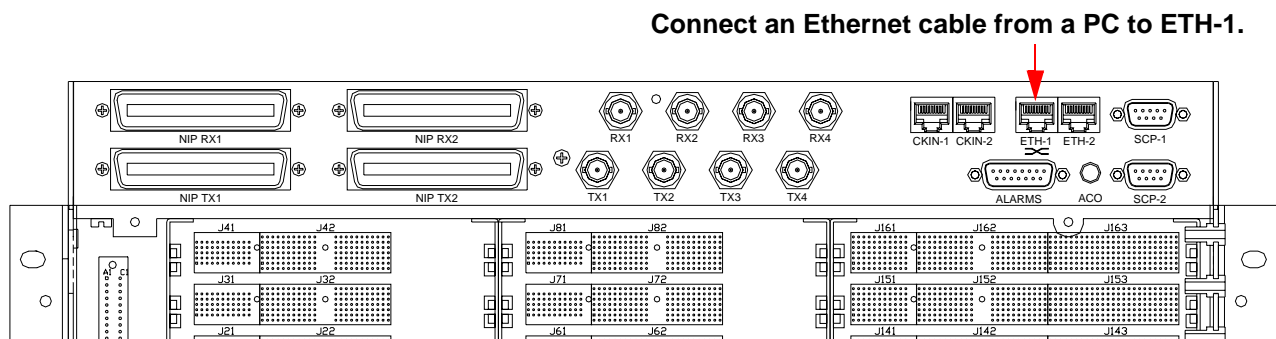

**ETH-1** is wired as a crossover port to enable simple interconnection to a PC Ethernet adaptor. To manage multiple **BROADway** systems at the same site simply plug a straight-through cable from **ETH-2** of the first **BROADway** chassis to **ETH-1** of the next system. Continue to cable (daisy-chain) from **ETH-2** to **ETH-1** for as many **BROADway** chassis as you have.

The **ETH-1** and **ETH-2** ports are female, RJ45 connectors. For pinout information on **ETH-1** and **ETH-2**, see *ETH-1 and ETH-2 Connector Pinouts* on page A-3.

## Installation

### Cabling the Network Synchronization Port

## Cabling the Network Synchronization Port

There are two chassis types, BITS and ITU; the difference is in the number and type of network synchronization ports. The network synchronization ports (**CKIN-1** and **CKIN-2**) can be connected to an external synchronization source that is typically traceable to a Stratum 1 level primary reference source. In the U.S. and Canada the BITS chassis expects to see a D4 or ESF framed T1 signal at this input. In countries that utilize an E1 network hierarchy, the ITU chassis expects to see a ITU-T G.703 2.048 MHz square wave signal. These connections are optional and should only be used when external timing is required. If a single external input only is available, it should always be connected to **CKIN-1** rather than **CKIN-2**. For more information about network synchronization, refer to *Timing and Synchronization* in the online help.

### Cabling the Clock Ports on the BITS Chassis

On the front panel of the chassis are two synchronization clock ports: **CKIN-1** and **CKIN-2** (one is redundant for the other). **CKIN-1** connects to NSP-1, and **CKIN-2** connects to NSP-2.

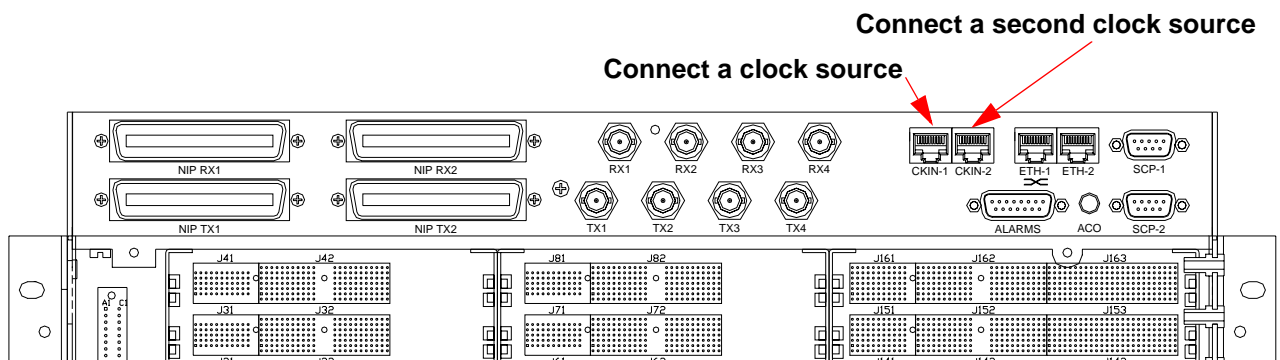

The **CKIN-1** and **CKIN-2** ports are female, RJ45 connectors. For pinout information on **CKIN-1** and **CKIN-2**, see *CKIN-1 and CKIN-2 Connector Pinouts (BITS Only)* on page A-4.

## Cabling the Clock Ports on the ITU Chassis

On the front panel of the chassis are two pairs of synchronization clock ports: **CKIN-1** and **CKOUT-1**, and **CKIN-2** and **CKOUT-2** (one pair is redundant for the other). **CKIN-1** and **CKOUT-1** are connected to NSP-1, and **CKIN-2** and **CKOUT-2** are connected to NSP-2.

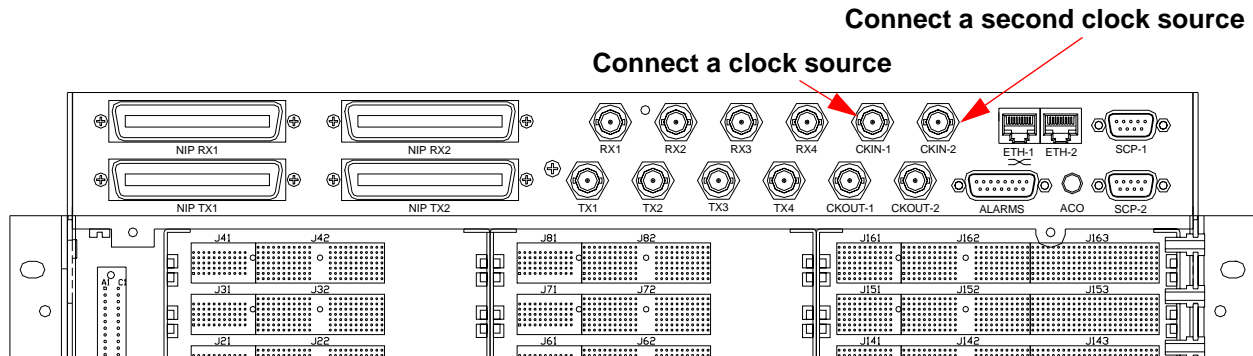

Connect the **CKOUT** ports to provide the timing signal to a further piece of communications equipment. The **CKIN-1**, **CKOUT-1**, **CKIN-2**, and **CKOUT-2** ports are 75ohm BNC connectors.

## Cabling the Alarm Ports

The **ALARMS** port supports four alarm contact connections: two inputs and two outputs. These contacts can be used to provide additional external alarms (audible and visual) when an alarm occurs on the **BROADway** system as well as to collect alarms arriving from external sources.

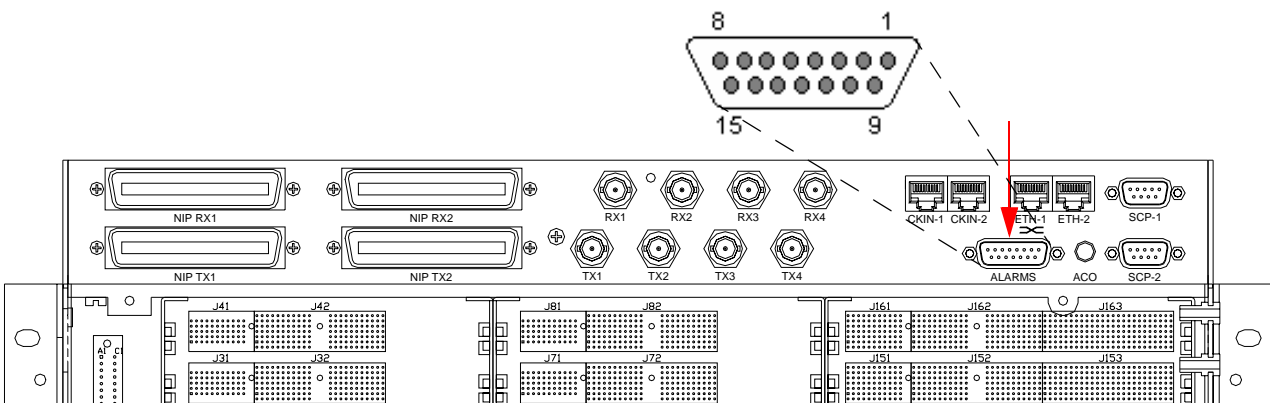

The **ALARMS** port is a female, DB15 connector.

The **ALARMS** port provides two alarm sense inputs, and two alarm generation outputs.

- **Alarm sense #1 and #2 (alarm inputs)**—These are used to collect alarms coming from an external source, such as other equipment, high water sensor, fire alarms, and so forth.

## Installation

### Cabling the Alarm Ports

---

- **Alarm generation #1 and #2 (alarm outputs)**—These are used to generate an alarm from the **BROAD**way chassis to an external unit, such as an alarm siren, aisle alarm lights, alarm telemetry systems, and so forth.

The **ALARMS** port is a female DB15 port. The following table describes the pinout of the **ALARMS** port. The contacts closures for alarm output ports are in the *normal* state when no alarm is present in the system.

Pin	Name	
1	normally open	alarm generation #1 (interpreted as a Critical/Major alarm)
2	common	
3	normally closed	
4	normally open	alarm generation #2 (interpreted as a Minor alarm)
5	common	
6	normally closed	
7, 8	not used	
9	ALMSNS2N	alarm sense #2 (can be configured for Critical, Major, or Minor)
10	ALMSNS2P	
11	ALMSNS1N	alarm sense #1 (can be configured for Critical, Major, or Minor)
12	ALMSNS1P	
13	Ground	
14	not used	
15	+5V DC reference voltage	

Using the **ALARMS** port, you can do either or both:

- Connect none, one, or two external sources to alarm sense #1 and #2 to indicate when an alarm is coming from the external source.
- Connect none, one, or two external units to the alarm generation #1 and #2 to tell the external units when an alarm has occurred on the **BROAD**way system.

### Alarm Input Sensing

The **ALARMS** port provides two separate circuits to detect when an alarm is generated from an external source. The circuit will sense an alarm condition when an external +5V potential is placed across pins 11 and 12 (**ALMSNS1**) or pins 9 and 10 (**ALMSNS2**). These pins are isolated from the **BROAD**way chassis. If an external voltage is not readily available, a 5V reference and ground are supplied on pins 13 and 15 and can be looped back onto pins 9 and 10 or 11 and 12, respectively, using the relay contacts.

## Alarm Output Reporting

During a Critical or Major alarm condition on **BROADway**, the normally open contact (pin 1) is closed, and the normally closed contact (pin 3) is opened.

During a Minor alarm condition on **BROADway**, the normally open contact (pin 4) is closed, and the normally closed contact (pin 6) is opened.

## Alarm Cut Off (ACO)

The Alarm Cut Off button on the front I/O panel is used to silence the current alarm output. A new alarm will re-activate the alarm closures.

## Installing the NSP101 Control Card

The NSP101 control card is the heart of the **BROADway** system and contains the narrowband switch matrix, the integrated IP router, the network timing synchronization subsystem and the management interface into the **BROADway** node.

**BROADway** always requires at least one NSP101 card to operate. Two NSP101 cards can be installed to provide redundant operation of the system. If a single NSP101 is used it should be installed in the NSP-1 card slot. The second, redundant NSP101 should be installed in the NSP-2 card slot.

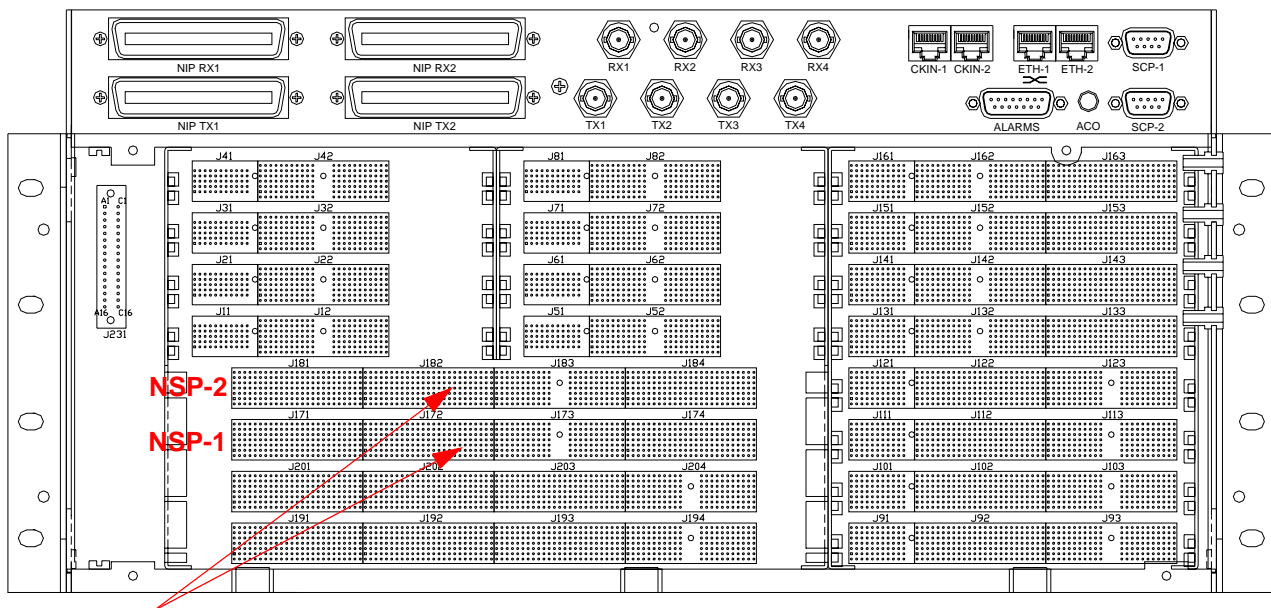

Insert one or two NSP101 cards

## Installation

### Installing the NSP101 Control Card

To install the NSP101, open the ejector tabs and slide the card into its proper slot until you feel resistance, then push to close the ejector tabs into their locking position against the metal rails. Verify that the card is firmly placed by applying pressure to the ejector tabs to seat the card fully in the chassis.

**WARNING!** WHEN INSTALLING OR REPLACING **BROADWAY** HARDWARE, ALWAYS ADHERE TO GOOD PRACTICE WITH RESPECT TO **ESD PROCEDURES**—USE A REGULARLY AND PROPERLY TESTED GROUNDING STRAP.

Each NSP101 has eight front panel LED indicators. From left to right, the two rows of indicators on each NSP101 indicate NSP101 **module** operating status (common indicators to all control and line interface cards), **active** card, **power** input status and **Ethernet** line activity.

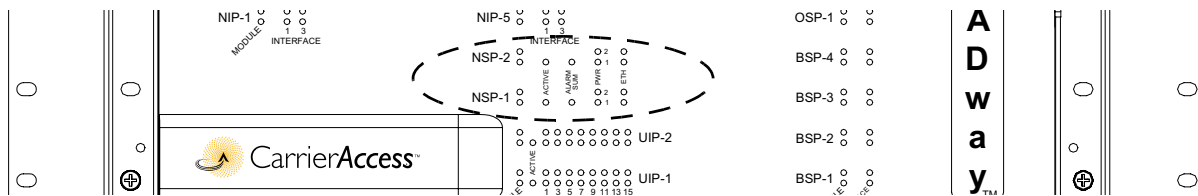

The following tables describe the status of the NSP101 control card based upon the front panel LED status of the card.

MODULE Red LED (Top)	MODULE Green LED (Bottom)	Status
Off	Off	No power to the card
Off	On	Card operating normally
On	Off	Card failure
On	On	Card initializing during system power up

Active or standby NSP101:

ACTIVE Green LED	Status
On	This is the Active NSP101
Blinking Slow	This is the Standby NSP101
Blinking Fast	The NSP101s are synchronizing databases

**CAUTION!** WHEN **BROADWAY** DATABASES ARE SYNCHRONIZING BETWEEN THE ACTIVE AND STANDBY **BROADWAY** SYSTEMS, THE **ACTIVE** LEDs ON THE **NSP101**S BLINK RAPIDLY TO SIGNIFY A FILE TRANSFER IS IN PROGRESS. YOU MUST WAIT UNTIL THESE **LED**S HAVE STOPPED FLASHING BEFORE YOU PERFORM ANY OPERATION TO RE-INITIALIZE THE **BROADWAY** SYSTEM EITHER THROUGH A REBOOT OR FORCED **NSP101** PROTECTION SWITCHOVER.

Alarm present:

<b>ALARM SUM Red LED</b>	<b>Status</b>
Off	No alarm is present
On	Indicates there is at least one critical, major or minor active alarm in the chassis

Power input status:

<b>PWR Red LED #2 (Top)</b>	<b>PWR Red LED #1 (Bottom)</b>	<b>Status</b>
Off	Off	Both power feeds present; operating normally
Off	On	Power FEED A is not operating
On	Off	Power FEED B is not operating

By default, **BROADway** is software configured to expect redundant power (using **FEED A** and **FEED B**). If you do not wire one of these inputs, the **PWR** LEDs will lamp as if there was an alarm condition. For more information about how to wire **FEED A** and **FEED B**, see *Cabling Power and Ground* on page 2-6.

If you are only using **FEED A** (not **FEED B**), you can configure the **BROADway** software to disable power input redundancy and disable the appropriate red LED. For information about how to configure your system to disable power input redundancy, refer to the online help.

Ethernet port activity:

<b>ETH Green LED #2 (Top)</b>	<b>ETH Yellow LED #1 (Bottom)</b>	<b>Status</b>
Off	Off	ETH-1 or ETH-2 not connected (link down)
Off	On	ETH-1 or ETH-2 connected (link up)
Flashing	On	Network activity on ETH-1 or ETH-2

## Installation

### Installing the NIP400 Line Interface Card

## Installing the NIP400 Line Interface Card

**BROADway** supports up to eight NIP400 quad T1/E1 line interface cards installed in slots NIP-1 through NIP-8. To support NIP400 redundant operation, you must install a NIP400 card in slot NIP-8.

### Insert NIP400 cards (optional)

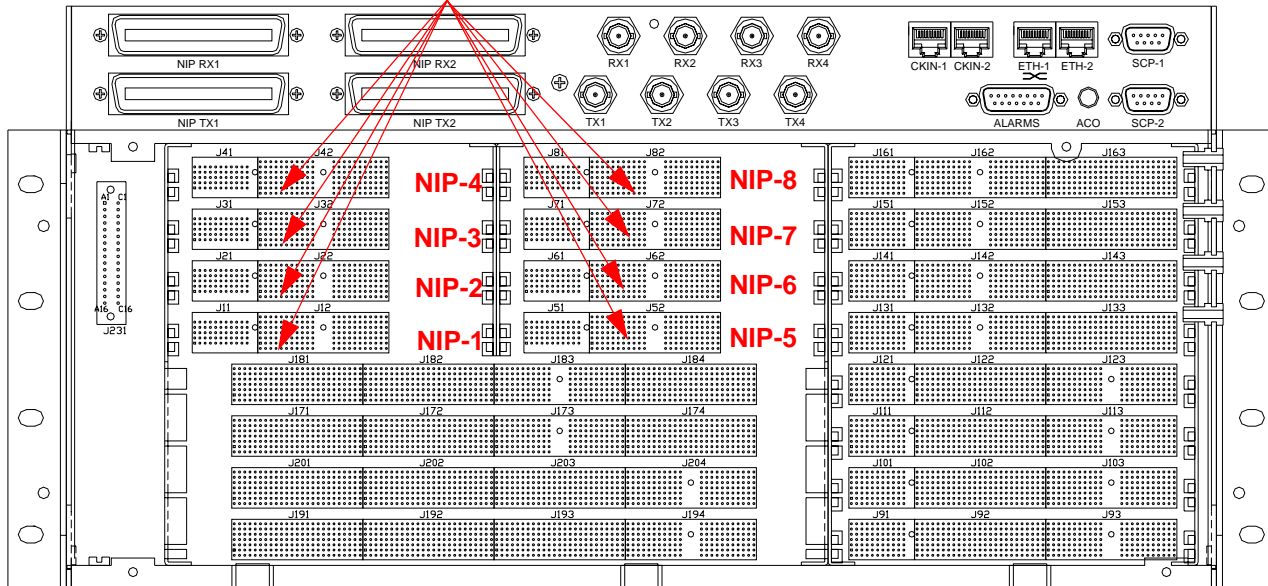

To install the NIP400, open the ejector tab and slide the card into its proper slot until you feel resistance, then push to close the ejector tab into its locking position against the metal rail (the NIP400 has a single ejector only). Check that the card is firmly in place by applying pressure to the ejector tab and the edge of the circuit board to seat the card fully into the chassis. If you are replacing a NIP400 card, wait at least three seconds after removing a NIP400 card before inserting a new one.

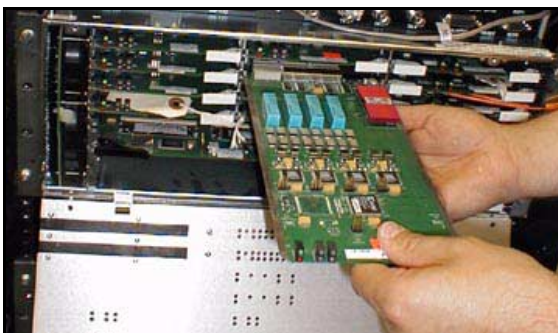

**WARNING!** WHEN INSTALLING OR REPLACING **BROADway** HARDWARE, ALWAYS ADHERE TO GOOD PRACTICE WITH RESPECT TO ESD PROCEDURES—USE A REGULARLY AND PROPERLY TESTED GROUNDING STRAP.



## Cabling the NIP400

Use the **NIP TX1**, **NIP TX2**, **NIP RX1**, and **NIP RX2** 25 pair connectors on the front I/O panel to connect the eight NIP400 slots in the **BROAD**way chassis to your punch down blocks or DSX panels. The **NIP TX1** and **NIP RX1** connectors support slots NIP-1 through NIP-4, and the **NIP TX2** and **NIP RX2** connectors support slots NIP-5 through NIP-8. If you are using NIP-8 as a redundant card slot, do not cable any interfaces to the NIP-8 slot.

For cable pinouts of **NIP TX1**, **NIP TX2**, **NIP RX1**, and **NIP RX2**, see *NIP400 Connector Pinouts (NIP TX1–RX1, NIP TX2–RX2)* on page A-5.

To attach a cable to the 25 pair connectors:

1. Plug in the female amphenol cable to the 25 pair connection **NIP TX1**.
2. Verify that the c-clips that slip over the right hand side of the four connectors are closed to prevent against accidental disconnect.
3. Repeat the previous step for **NIP TX2**, **NIP RX1**, and **NIP RX2**.
4. Dress the cables out to the left of the chassis. Connect the other end of the cables to your terminating equipment.

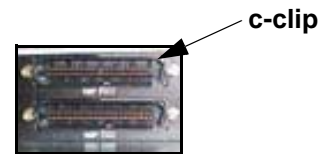

### Connect to DSX panels or punch down blocks

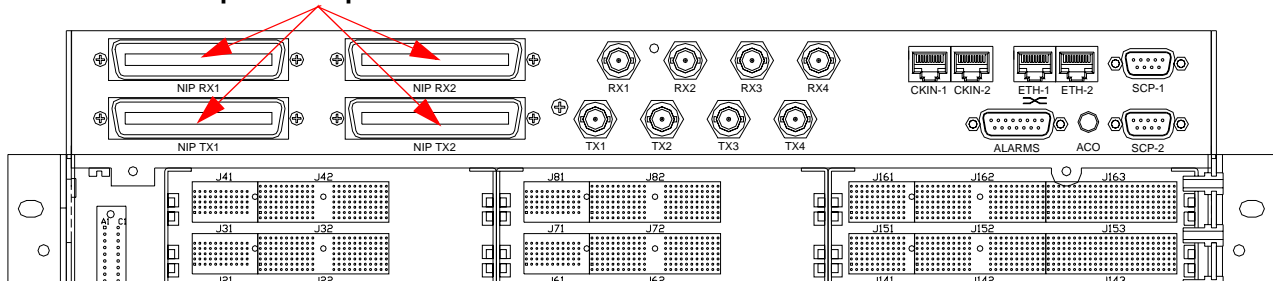

5. To remove the cable, slide the top right hand corner of the c-clip to the left to enable the cable to be easily removed otherwise damage to the cable can result and the cable might not re-engage.



## Installation

### Installing the NIP400 Line Interface Card

## NIP400 LED Indicators

Each NIP400 line card has two LED indicators that describe the operational status of the **module** itself. There is a further single LED indicator per physical interface that describes the status of the modules four line interfaces.

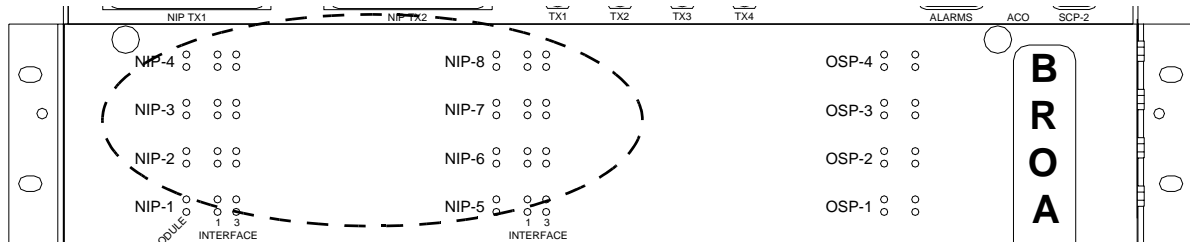

The following tables describe the LED status of the NIP400 line interface card.

MODULE Red LED (Top)	MODULE Green LED (Bottom)	Status
Off	Off	No power to the card
Off	On	Card operating normally
On	Off	Card failure
On	On	Card initializing during system power up

If the card failure sequence is displayed, remove the card and re-insert it into the chassis. If the card failure sequence is still displayed, then replace the card.

Line status (per port):

Port LED	Port State
off	The card is not configured, or alarm reporting is disabled on the interface
green	Interface operating normally
blinking green	Interface performing a diagnostic test
blinking red	Yellow alarm (RAI)
red	Interface failure (LOS, OOF, AIS)

## Installing the NHP160 Line Interface Card

**BROADway** supports up to two NHP160 sixteen port T1/E1 line interface cards installed in slots UIP-1 and UIP-2. If you plan to support NHP160 redundant operation, you must install an NHP160 card in slot UIP-2, even if there is no NHP160 card installed in slot UIP-1 (the last four ports on the NHP160 in UIP-2 are designated the protection ports for both slots).

### Cabling and Inserting the NHP160 Line Interface Card

Before inserting the NHP160 line cards into the **BROADway** system, you must seat the NHP160 cable into its SCSI connector on the card. The NHP160 cards are cabled directly from a port on the line card itself. The electrical cables are dressed to the left hand side of the chassis.

To cable and insert the NHP160 cards:

1. Attach the NHP160 cables to each NHP160 card.

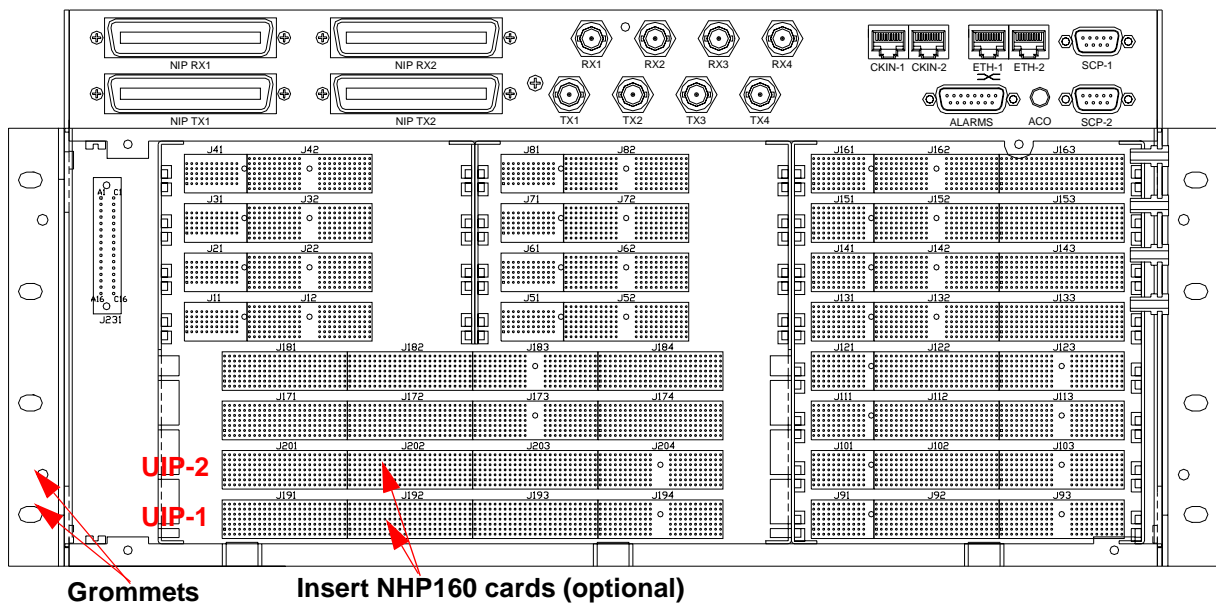

2. Insert the NHP160 card into the chassis. Open the ejector tabs and slide the card into its proper slot until you feel resistance, then push to close the ejector tabs into their locking position against the metal rails. Check that the card is firmly in place by applying pressure to the ejector tabs to seat the card fully into the chassis.

**WARNING!** WHEN INSTALLING OR REPLACING **BROADWAY** HARDWARE, ALWAYS ADHERE TO GOOD PRACTICE WITH RESPECT TO ESD PROCEDURES—USE A REGULARLY AND PROPERLY TESTED GROUNDING STRAP.

3. Dress the cables through the cut-outs in the metal chassis on the left hand side of the system. Ensure that you leave enough slack in the NHP160 cable to enable the fan tray to be removed without interference.

## Installation

### Installing the NHP160 Line Interface Card

4. Connect the other end of the cables to your terminating equipment.

For cable pinouts of the NHP160 SCSI port connector, see *NHP160 Connector Pinouts* on page A-8.

## NHP160 LED Indicators

Each NHP160 line card in a UIP slot has two LED indicators that describe the operational status of the **module** itself. There is a further single LED indicator per physical interface that describes the status of the line interface. The **active** LED position is not used on the NHP160.

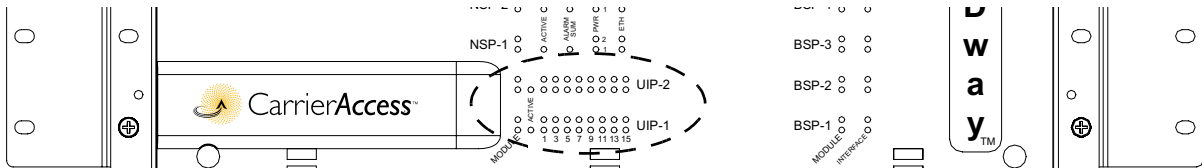

The following tables describe the status of the NHP160 line interface card based upon the front panel LED status of the card.

MODULE Red LED (Top)	MODULE Green LED (Bottom)	Status
Off	Off	No power to the card
Off	On	Card operating normally
On	Off	Card failure
On	On	Card initializing during system power up

If the card failure sequence is displayed, remove the card and re-insert it into the chassis. If the card failure sequence is still displayed, then replace the card.

Line status (per port):

Port LED	Port State
off	The card is not configured, or alarm reporting is disabled on the interface
green	Interface operating normally
blinking green	Interface performing a diagnostic test
blinking red	Yellow alarm (RAI)
red	Interface failure (LOS, OOF, AIS)

## Installing the BSP200 Line Interface Card

**BROAD**way supports up to four BSP200 single port DS3/mapper line interface cards installed in positions BSP-1, BSP-2, BSP-3 and BSP-4. If you plan to support redundant BSP operation, you should preferably install the redundant BSP module in BSP-4. When cabling to other DS3 equipment in an office environment. Follow the design rules for the distance between DS3 terminal equipment and DSX-3 bays and inter-bay patch panels; DS3 signals can be very sensitive to incorrectly wired segments.

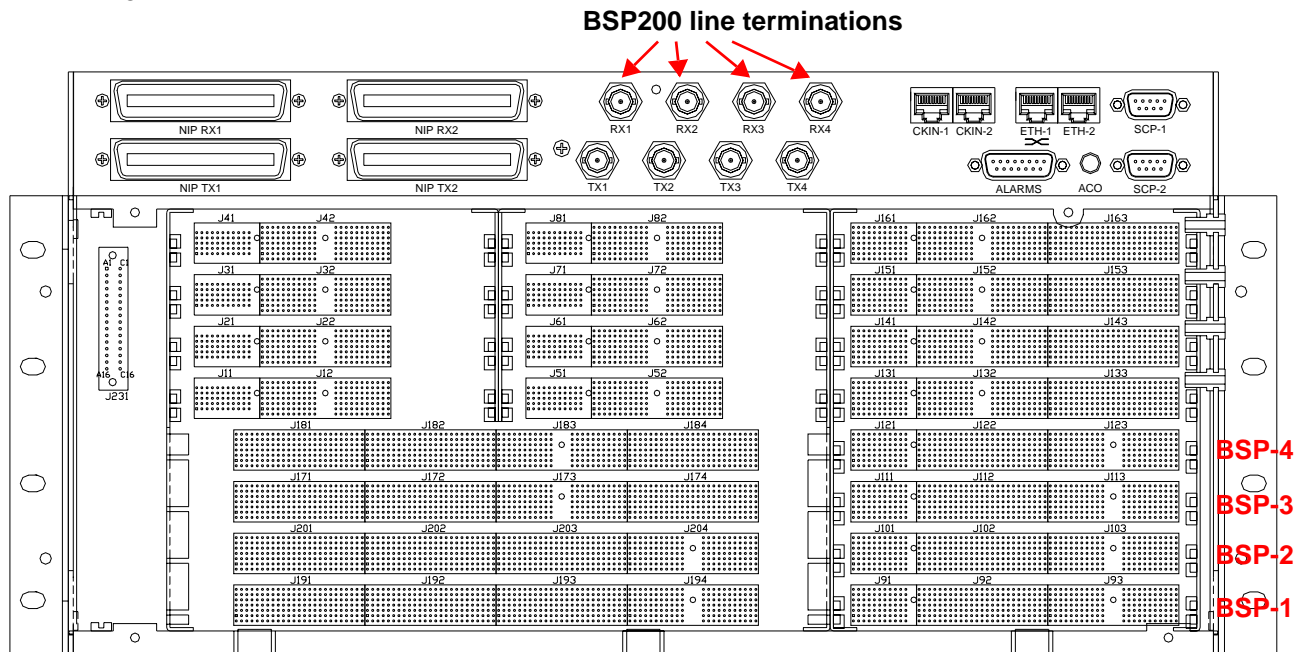

Insert the BSP200 card into the chassis. Open the ejector tabs and slide the card into its proper slot until you feel resistance, then push to close the ejector tabs into their locking position against the metal rails. Check that the card is firmly in place by applying pressure to the ejector tabs to seat the card fully into the chassis.

**WARNING!** WHEN INSTALLING OR REPLACING **BROAD**WAY HARDWARE, ALWAYS ADHERE TO GOOD PRACTICE WITH RESPECT TO ESD PROCEDURES—USE A REGULARLY AND PROPERLY TESTED GROUNDING STRAP.

## Installation

### Installing the BSP200 Line Interface Card

## Cabling the BSP200

The BSP200 line interface cards use the 75Ohm BNC ports **TX1/RX1**, **TX2/RX2**, **TX3/RX3**, and **TX4/RX4** respectively on the top I/O panel of the **BROADway** chassis.

To make your DS3 cable connections:

1. Connect the DS3 inputs by connecting 75Ohm BNC coaxial cables to **TX1/RX1** through **TX4/RX4**.

### Connect BNC coaxial cables

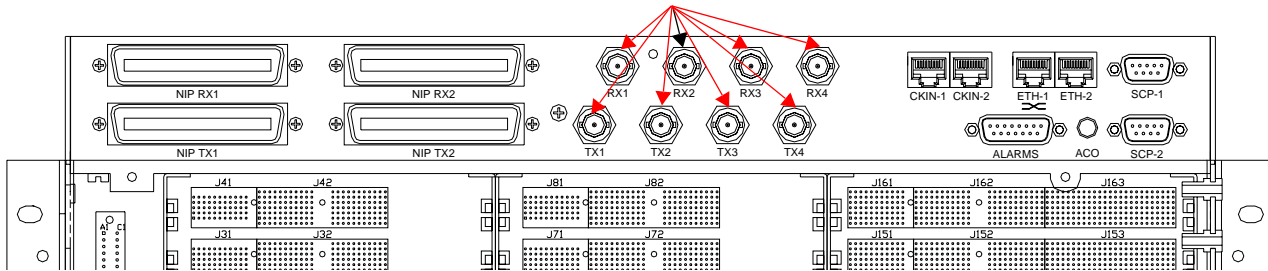

2. Connect the other end of these cables to your DS3 terminating equipment.

## BSP200 LED Indicators

Each BSP200 line card has two LED indicators that describe the operational status of the **module** itself. There are a further two LED indicators per card that describe the status of the line interface.

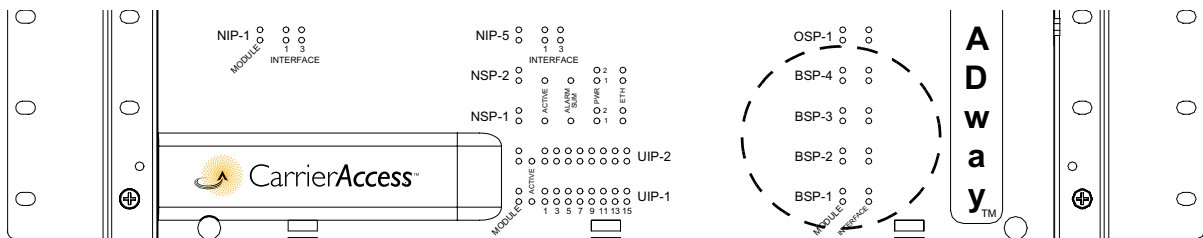

The following tables describe the status of the BSP200 line interface card based upon the front panel LED status of the card.

MODULE Red LED (Top)	MODULE Green LED (Bottom)	Status
Off	Off	No power to the card
Off	On	Card operating normally
On	Off	Card failure
On	On	Card initializing during system power up

If the card failure sequence is displayed, remove the card and re-insert it into the chassis. If the card failure sequence is still displayed, then replace the card.

Line status (per port):

<b>INTERFACE Red LED (Bottom)</b>	<b>INTERFACE Green LED (Top)</b>	<b>Status</b>
Off	Off	The card is not configured, or alarm reporting is disabled on the interface
Off	On	Interface operating normally
Off	Blinking	Interface performing a diagnostic test
On	Off	Interface failure (LOS, OOF, AIS)
Blinking	Off	Yellow alarm (RAI)
On	On	Interface initializing during system power up

## Installation

### Installing OSP155/ESP155/BCP155 Line Interface Cards

# Installing OSP155/ESP155/BCP155 Line Interface Cards

**BROADway** supports up to four OSP155, ESP155 or BCP155 single port OC3/STM1 line cards installed in positions OSP-1, OSP-2, OSP-3 and OSP-4. The OSP155 is a singlemode fiber interface operating at 155Mbps, the ESP155 is a coaxial interface operating at 155Mbps and the BCP155 is a reduced functionality 155Mbps singlemode fiber interface for the direct interconnection of **BROADway** chassis.

The OSP155 and BCP155 cards contain a Class I Laser Product which conforms to the applicable requirements of 21 CFR Subchapter J.

**DANGER!** DO NOT UNPLUG THE FIBER OPTIC CABLES OR LOOK DIRECTLY INTO THE END OF A FIBER WHEN THE **OSP155** OR **BCP155** CARD IS POWERED UP. THERE IS A STRONG POSSIBILITY OF SEVERE EYE DAMAGE IF YOU LOOK IN THE END OF A LIT FIBER CABLE OR INTERFACE.

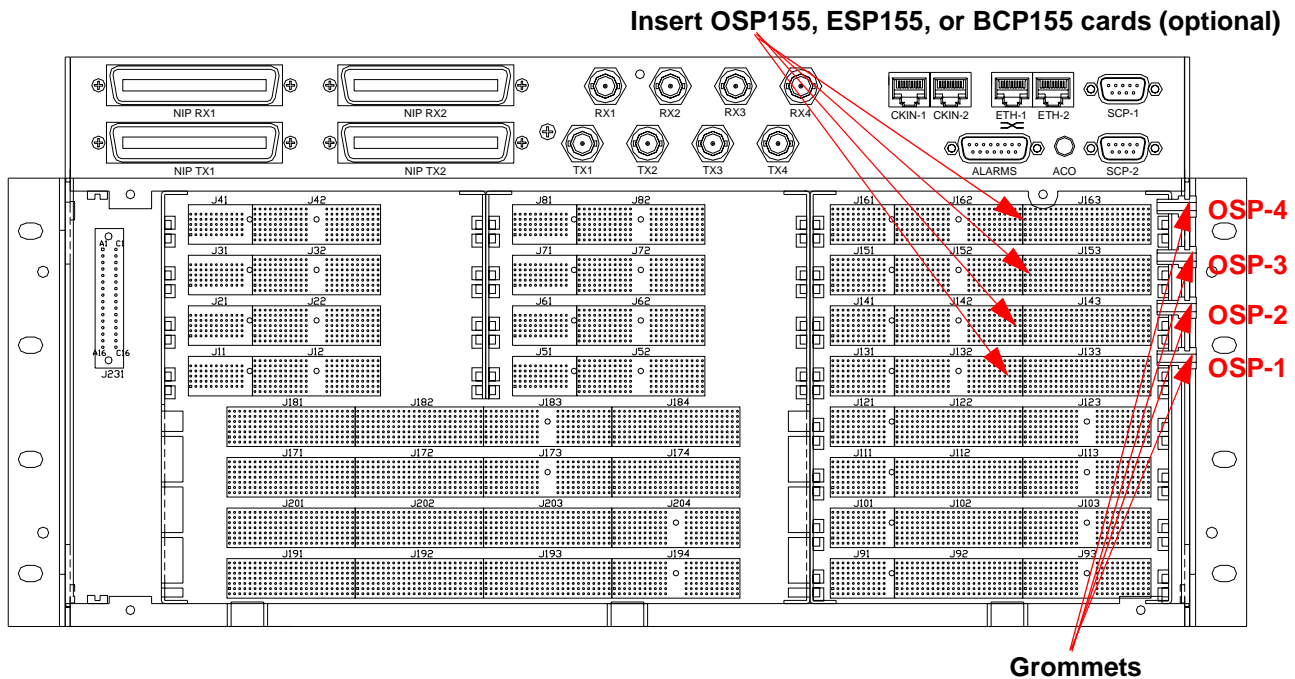

Cable the OSP155, ESP155, and BCP155 cards directly. Dress the fiber cables to the right of the chassis through the grommets provided in the right hand side of the unit.

The OSP155 and BCP155 cards use a duplex SC-type fiber optic cable connector. The ESP155 card uses a 75Ohm SMB coaxial connector. For more information about this type of fiber cable specification, see *Appendix A, Ports and Cables*.



### Cabling the OSP155 and BCP155

OSP155 and BCP155 cables should be attached to the line interface card before installing in the **BROADway** chassis. Be careful when installing OSP155 or BCP155 cards; minimize the potential for eye damage by not looking directly into any fiber optic cable or optical transceiver port when the card is inserted into a powered system. To cable and insert the OSP155 and BCP155 cards:

1. **First** attach the duplex fiber optic cable to the line interface port:

#### Singlemode Fiber Optic Cable



Be careful not to bend the cable too sharply, or you might break the fiber inside



Insert the singlemode fiber optic cable

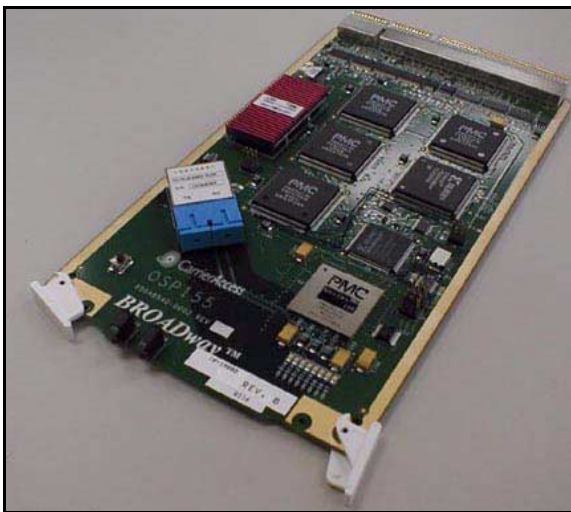

Remove the dust plugs from the optical transceiver

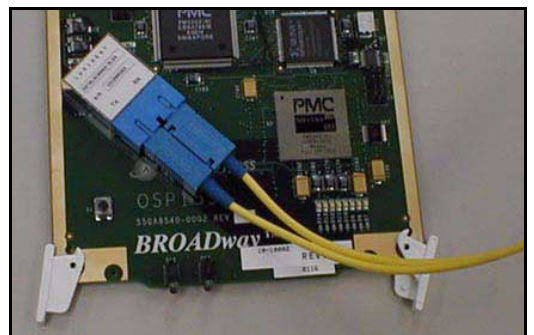
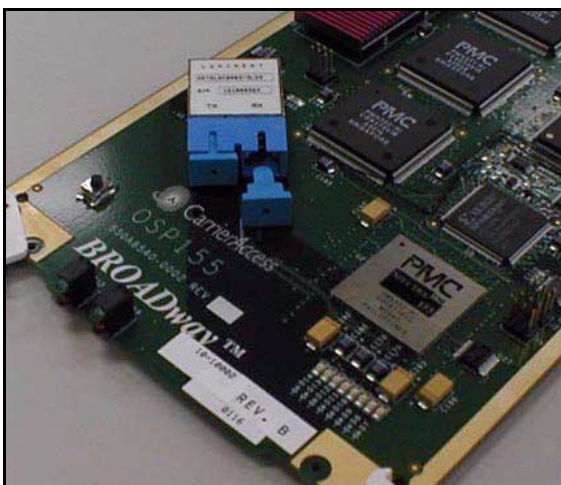
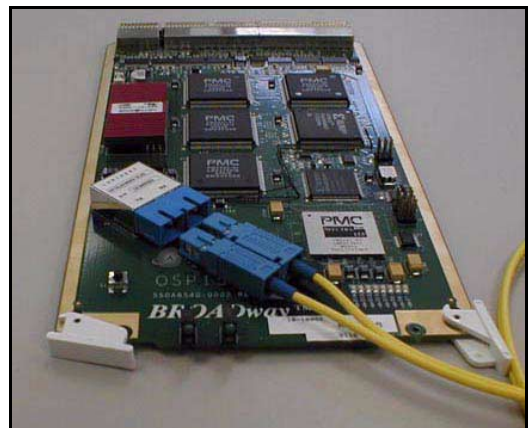

## Installation

### Installing OSP155/ESP155/BCP155 Line Interface Cards

---

2. Insert the cards into the chassis. Open the ejector tabs and slide the card into its proper slot until you feel resistance, then push to close the ejector tabs into their locking position against the metal rails. Verify that the card is firmly in place by applying pressure to the ejector tabs to seat the card fully into the chassis.

---

**WARNING!** WHEN INSTALLING OR REPLACING **BROADWAY** HARDWARE, ALWAYS ADHERE TO GOOD PRACTICE WITH RESPECT TO **ESD PROCEDURES**—USE A REGULARLY AND PROPERLY TESTED GROUNDING STRAP.

---



3. Dress the cables through the grommets at the right hand side of the chassis. The duplex fiber cable fits snugly in each slot.

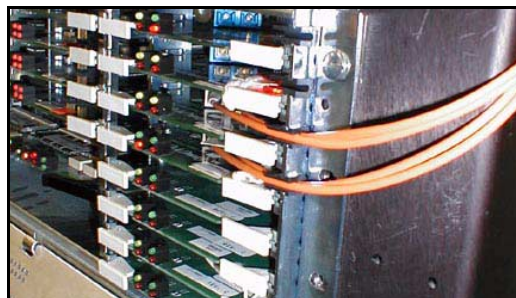

4. Connect the other end of the fiber cables to your fiber terminating equipment.

## **Cabling the ESP155**

ESP155 cables should be attached to the line interface card before installing in the **BROAD**way chassis. To cable and insert the ESP155 line interface card:

1. Attach the 75Ohm coaxial cables to the transmit and receive SMB ports on the line interface card.
2. Insert the ESP155 card into the chassis. Open the ejector tabs and slide the card into its proper slot until you feel resistance, then push to close the ejector tabs into their locking position against the metal rails. Check that the card is firmly in place by pushing the card itself (not the ejectors) back one further time into the chassis.
3. Dress the cables through the grommets at the right hand side of the chassis. The cable fits snugly in each slot.

## **OSP155, BCP155, and ESP155 LED Indicators**

Each OSP155, BCP155 and ESP155 line card in a OSP slot has two LED indicators that describe the operational status of the **module** itself. There are a further two LED indicators per card that describe the status of the line interface.

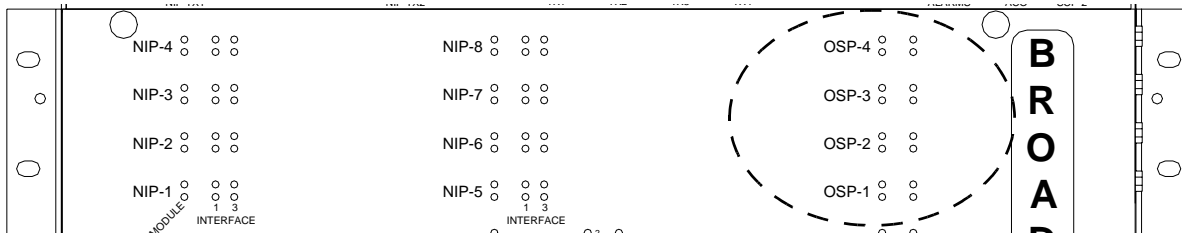

The following tables describe the status of the OSP155, ESP155 or BCP155 line interface card based upon the front panel LED status of the card.

<b>MODULE Red LED (Top)</b>	<b>MODULE Green LED (Bottom)</b>	<b>Status</b>
Off	Off	No power to the card
Off	On	Card operating normally
On	Off	Card failure
On	On	Card initializing during system power up

If the card failure sequence is displayed, remove the card and re-insert it into the chassis. If the card failure sequence is still displayed, then replace the card.

## Installation

### Attaching the Front Panel

---

Line status (per port):

INTERFACE Red LED (Bottom)	INTERFACE Green LED (Top)	Status
Off	Off	The card is not configured, or alarm reporting is disabled on the interface
Off	On	Interface operating normally
Off	Blinking	Interface performing a diagnostics test
On	Off	Interface failure (LOS, OOF, AIS)
Blinking	Off	Yellow alarm (RAI)
On	On	Interface initializing during system power up

## Attaching the Front Panel

After inserting the cards and cabling the **BROAD**way you must secure the front panel to the **BROAD**way chassis.

To attach the front panel:

1. Place the front panel on the front of the chassis, hooking the slots into the bottom and lining up the four screws.
2. Flip up the front panel to close it securely against the front of the chassis.
3. Screw in the four screws to properly secure the front panel to the chassis.



## Applying Power to the Chassis

Locate the power switches on the rear of the chassis (**O/I**) and turn them on (**I**). After powering up the **BROADway** chassis, all the LEDs will go through an initialization process where they all light. After the cards have initialized, only the top left (**MODULE**) green LED on each card and one of the NSP101 **ACTIVE** LEDs will lamp as shown in the following figure. After the standby NSP101 has synchronized its database with the active NSP101, its **ACTIVE** LED will link green slowly. These LEDs remain lit during normal operation.

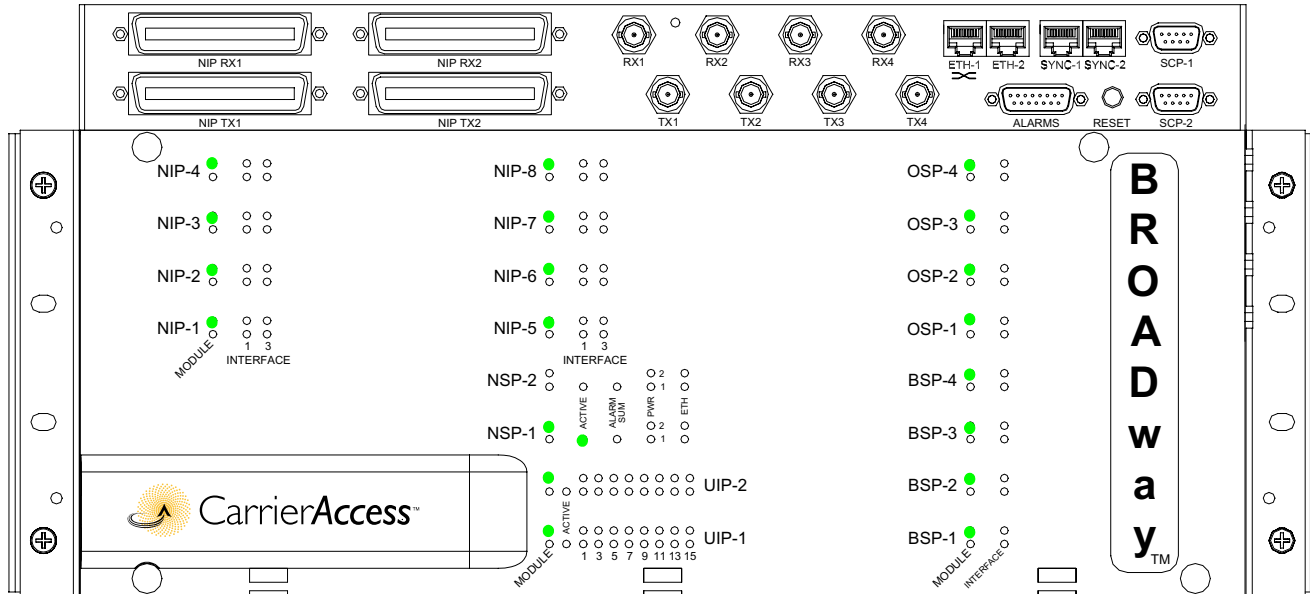

Slots that have no cards installed will remain unlit.

**DANGER!** THIS SYSTEM HAS TWO POWER INPUT CONNECTIONS. DISCONNECT BOTH BEFORE SERVICING TO AVOID ELECTRIC SHOCK. SEE **CABLING POWER AND GROUND** ON PAGE 2-6.

Should you need to power cycle the **BROADway** system then power down the chassis using the power switches at the rear of the chassis (**O/I**) and wait at least five seconds before powering it back on.

## Maintaining BROADway Hardware

To maintain your **BROADway** hardware you might need to:

- Install new cards to increase capacity or gain new functionality
- Replace failed cards with new cards
- Clean the fan filter, and replace it when needed

### Installing New Cards

If you have a previously installed and partially populated **BROADway** chassis and you need to add more cards to increase capacity, you can install those cards using the same methods described earlier in this chapter. **BROADway** cards are hot swappable and can be removed and re-inserted while the chassis is powered.

---

**WARNING!** WHEN INSTALLING OR REPLACING **BROADWAY** HARDWARE, ALWAYS ADHERE TO GOOD PRACTICE WITH RESPECT TO **ESD** PROCEDURES—USE A REGULARLY AND PROPERLY TESTED GROUNDING STRAP.

---

### Installing a Redundant NSP101 Card

To install a redundant NSP card, install the NSP card as described in *Installing the NSP101 Control Card* on page 2-13. When a redundant NSP card, its **MODULE** LED flashes green to indicate it is in an active standby mode.

### Installing Additional NIP400 Cards

To install an additional NIP400 card, install the NIP400 cards as described in *Installing the NIP400 Line Interface Card* on page 2-16.

---

**NOTE:** You might need to cable additional NIP connectors. For example, if the original system had only four NIP400 cards, you might have only cabled **NIP RX1** and **NIP TX1**. If you are now adding one, two, three, or four additional NIP400 cards, you will need to cable **NIP RX2** and **NIP TX2** as described in *Cabling the NIP400* on page 2-17.

---

### Installing Additional NHP160 Cards

To install an additional NHP160 card, install the NHP160 card as described in *Installing the NHP160 Line Interface Card* on page 2-19.

### Installing Additional BSP200 Cards

To install additional BSP200 cards, install the BSP200 cards as described in *Installing the BSP200 Line Interface Card* on page 2-21.

---

**NOTE:** You might need to cable additional TX and RX connectors. For example, if the original system had only three BSP200 cards, you might have only cabled **TX1/RX1**, **TX2/RX2** and **TX4/RX4**. If you are now adding a BSP card in BSP-3, you will need to cable **TX3/RX3** as described in *Cabling the BSP200* on page 2-22.

---

### **Installing Additional OSP155, ESP155 or BCP155 Cards**

To install an additional OSP155, ESP155, or BCP155 card, install the card as described in *Installing OSP155/ESP155/BCP155 Line Interface Cards* on page 2-24.

---

**DANGER!** DO NOT UNPLUG THE FIBER OPTIC CABLES TO THE **OSP155** OR **BCP155** CARDS WHEN THE MODULE IS POWERED UP. THERE IS A STRONG POSSIBILITY OF SEVERE EYE DAMAGE IF YOU LOOK IN THE END OF A LIT FIBER CABLE OR INTERFACE.

---

### **Replacing Failed Cards**

All **BROADway** control and line interface cards are hot swappable. If an in-service card fails you can replace it while the system remains operational.

---

**WARNING!** WHEN HOT SWAPPING CARDS, BE SURE TO INSTALL THE NEW CARDS SLOWLY AND CAREFULLY. PREFERABLY, ALLOW AT LEAST **30** SECONDS BETWEEN ANY CARD REMOVALS AND RE-INSERTIONS.

---

#### **To Replace an NSP101 Card**

1. Remove the NSP101 card by opening the ejector tabs and sliding out the card.
2. Insert a new NSP101 card as described in *Installing the NSP101 Control Card* on page 2-13.

#### **To Replace a NIP400 Card**

1. Remove the NIP400 card by opening the ejector tab and sliding out the card.
2. After at least three seconds, insert a new NIP400 card as described in *Installing the NIP400 Line Interface Card* on page 2-16.

#### **To Replace an NHP160 Card**

1. Remove the cable from the grommet so that you can easily slide the card out.
2. Remove the NHP160 card by opening the ejector tabs and sliding out the card.
3. Detach the NHP160 cable from the card.
4. Reattach the NHP160 cable to the new NHP160 card.
5. Insert the new NHP160 card as described in *Installing the NHP160 Line Interface Card* on page 2-19.

#### **To Replace a BSP200 Card**

1. Remove the BSP200 card by opening the ejector tabs and sliding out the card.
2. Insert the BSP200 card as described in *Installing the BSP200 Line Interface Card* on page 2-21.

#### To Replace a BCP155, OSP155, or ESP155 Card

1. Remove the cable of the card from the grommet so that you can easily slide the card out.
2. Remove the card by opening the ejector and sliding out the card.
3. Detach the cable from the card.
4. Reattach the cable to the new card.
5. Insert the new card as described in *Installing OSP155/ESP155/BCP155 Line Interface Cards* on page 2-24.

---

**DANGER!** DO NOT UNPLUG THE FIBER OPTIC CABLES TO THE BCP155 OR OSP155 CARDS WHEN THE MODULE IS POWERED ON. THERE IS A STRONG POSSIBILITY OF SEVERE EYE DAMAGE IF YOU LOOK IN THE END OF A LIT FIBER CABLE OR INTERFACE.

---

#### Maintaining the Fan Tray

The chassis comes installed with a fan tray. Periodically, you must clean or replace the fan tray filter. You should plan to replace the fan filter at least once per year. New filters can be obtained directly from Carrier Access. To replace the fan filter:

1. Open the front panel of the **BROADway** chassis. The fan board is located on the left hand side of the chassis. You will remove the fan board, replace its fan filter, and re-insert the fan board.

---

**WARNING!** IT IS IMPORTANT THAT YOU REPLACE THE FAN BOARD WITHIN 30 MINUTES TO PREVENT THE SYSTEM FROM OVERHEATING. MAKE SURE YOU HAVE THE NEW FAN FILTER ON HAND BEFORE YOU REMOVE THE FAN BOARD.

---

2. Remove the fan board using the attached small plastic handle. The fan filter is located on the left hand side of the fan board.
3. Remove the fan filter (it is attached with Velcro).



Fan Board

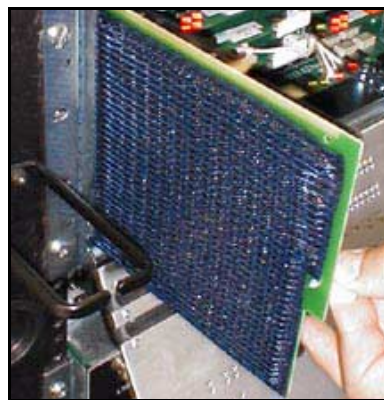

Fan Filter

4. Attach the new fan filter.
5. Re-insert the fan board.
6. Close the front panel.



# CHAPTER 3

---

## *Configuration*

### **In This Chapter**

- Overview
- Assigning an IP Address to the BROADway System
- Management Access to the BROADway System
- Logging In With the Web Browser Interface (GUI)
- Logging In With the Command Line Interface (CLI)
- Setting Up User Accounts
- Changing Your Password
- Setting the System Date and Time
- Setting System Node Parameters
- Managing the BROADway Configuration Database
- Using FTP with the BROADway System
- Upgrading System Software

## Overview

At this point, the **BROAD**way hardware should have been planned, mounted and cabled as described in *Chapter 2, Installation*.

Now, you must begin to configure the **BROAD**way system software for your application. There are two basic methods that can be used to configure the **BROAD**way system software. These are:

- Using the web browser graphical user interface (GUI)
- Using the command line interfaces (CLI) locally or from a Telnet session using TL1 and/or Packet Services (PS) commands

Most of your configuration work can be performed using either method of configuration (GUI or CLI) with the following exceptions:

- The initial IP address of the **BROAD**way system Ethernet interface must be configured through the CLI.
- Stacking of multiple systems can only be configured through the GUI.

You might find it easier to perform configuration work using the GUI. However, there are cases when you might prefer to use CLI:

- When you do not have access to a web browser
- When you need to write CLI scripts to interface the **BROAD**way management system to another machine
- When you want to perform network management using a CLI because your overall network management system operates under a CLI-based system.

To successfully configure your **BROAD**way system you must, at a minimum, follow these steps:

- Assign an IP address to the system
- Log into the system
- Assign line interface cards within the system
- Configure line interface parameters
- Make cross-connects through the system
- Configure packet services support

This chapter describes how to perform the initial configuration of the **BROAD**way system. For complete details about configuration, packet services, and diagnostics, refer to the online help.

## Assigning an IP Address to the BROADway System

Should you decide to access the **BROADway** system remotely through a Telnet or web browser interface, you must either use the default **BROADway** IP address, or use the TL1 and PS CLI to configure a new IP address for the node.

### Default BROADway IP Address

All **BROADway** systems are configured from the factory with a default IP address of 169.254.0.1 and a subnet mask of 255.255.0.0. This default scheme makes it easy for technicians with a standard DHCP client configured to attach to the unit for configuration purposes, however it also means that two **BROADway** systems should not be connected to the same network unless at least one of their IP addresses is first changed to avoid conflict.

---

**NOTE:** Users with PCs configured with static IP addresses will have to either change the IP address of their PC or of the **BROADway** system to enable IP communications. For more information, see *Assigning a Different IP Address* on page 3-4.

---

To manage the **BROADway** system using its default IP address, ensure that the PC that will be running the web browser GUI interface is directly attached to the **BROADway** Ethernet port using either a straight-through Ethernet patch cable (in which case it should be plugged into the port marked with an 'X') or a cross-over Ethernet cable (in which case it should be plugged into the other Ethernet port). Start the **BROADway** system and then restart the PC.

Microsoft Windows will default the IP address of a PC to an address in the range 169.254.0.1 to 169.254.255.255 should no DHCP server be available for certifying a DHCP client. This is known as Automatic Private IP Addressing (APIPA) and is intended to make it easy for home network users to construct small LAN's. For our purposes, the connection between the **BROADway** and the PC is a small LAN.

The following procedures are to be used for different Windows Operating System versions - note that these procedures will not upset the IT configuration of the PC; when you reboot the PC on the corporate network it will automatically re-acquire a proper IP address from the corporate DHCP server.

**Windows 98 and Windows NT:** Click the **Start** button, then **Run**, then type **winiipcfg** and click **OK**. From the drop-down list select your network interface card and then click **Release**, then **Renew**. The NIC will be assigned a new address in the 169.254.X.X range.

**Windows 2000, XP:** Reboot the PC and wait approximately 60 seconds for the DHCP client to timeout - the DHCP client will then default the IP address to the correct range.

To verify that the PC has an IP address in the correct range click the **Start** button, then **Run**, then type **command** and click **OK**. At the prompt, type **IPCONFIG** and press ENTER. The IP address of your LAN interface should begin with 169.254.X.X and the subnet mask should be 255.255.0.0. Type **exit** to exit the command shell. You can verify connectivity with the **BROADway** system by using the **PING 169.254.0.1** command from the Windows command shell prompt.

You are now ready to configure the **BROADway** system through the GUI as described in *Logging In With the Web Browser Interface (GUI)* on page 3-9, or by using a Telnet program as described on *Ethernet Port Command Line Access* on page 3-8.

## Assigning a Different IP Address

If you plan to use network interface bridging support in your **BROADway** system, you must create a bridge virtual interface (BVI) to create the IP address for management access, as described in *Creating a Bridge Virtual Interface (BVI)* on page 3-5. Otherwise, perform the following procedure.

To assign a different IP address to the **BROADway** system:

1. Connect your PC to the serial port **SCP-1** on the **BROADway** chassis using a null modem cable provided with the chassis (note **SCP-2** is for future use).
2. On your PC open a terminal emulation window, for example, HyperTerminal. The terminal emulation software should be set to VT100 emulation, 9600 baud, 8 data bits, no parity and 1 stop bit. Both hardware and software flow control options are disabled.

---

**NOTE:** If your terminal emulation software has the ability to configure a delay before sending information, make sure this is set for 10 ms.

---

3. In your terminal emulation window, press ENTER, and you should see the prompt **NSP1>** or **NSP2>**, depending upon which NSP101 card is currently active.
4. Log in to the **BROADway** system using the following TL1 command:

```
ACT-USER::NSP:1234::CUSTOMER,BROADWAY;
```

---

**NOTE:** The initial **BROADway** system has one default user account that is an administrative account. The case-sensitive user name of this default account is **CUSTOMER**, and the case-sensitive password of this default account is **BROADWAY**. You can use this default account to assign an IP address to the **BROADway** system.

---

5. Switch to the Packet Services command line interface by typing **ps** and pressing ENTER. You will see the **PS#** prompt.
6. Type **configure** and press ENTER. This enables a configuration mode; your prompt will change to **PS(config)#**.
7. Type **interface ethernet 0** and press ENTER.
8. Type **ip address <address> <mask>** and press ENTER, where **<address>** is the IP address of the system, and **<mask>** is the appropriate subnet mask (typically 255.255.255.0 for a standard class C subnet).
9. Type **exit** and press ENTER (to the **PS(config)#** prompt).
10. Type **exit** and press ENTER (to the **PS#** prompt).
11. Type **save running-config** and press ENTER to save the changes you made.
12. Type **exit** and press ENTER to leave the PS prompt and return to the NSP prompt.
13. Close your terminal emulation window.

After assigning an IP address to your system, you can use either Ethernet port (**ETH-1** and/or **ETH-2**) for network connectivity (as described in *Cabling the Ethernet Port* on page 2-9).

If at any point you need to change the initial IP address assigned to the **BROADway** system, you can do so as described in the online help.

### **Creating a Bridge Virtual Interface (BVI)**

Before you can add an interface to a bridge group, you should first create the bridge virtual interface (BVI) which attaches the bridge-group to the IP router. There is a one-to-one mapping between a BVI and a bridge-group; each BVI supports a single bridge-group. The BVI has an IP address which it utilizes to route its bridged traffic into the IP router and which can also be used to manage the **BROADway** system by performing the **manage-intf enable** command on the BVI.

You can enable and configure both Network Address Translation (NAT) and the DHCP relay agent on a BVI interface.

To **create** a BVI, use the following PS commands:

```
PS#configure
PS(NSP-config)#interface bvi <bvi number>
PS(NSP-config-bvi)#ip address <address> <mask>
```

**<bvi number>**—The number of the bridge virtual interface. You should use the same number that was configured for the bridge group.

**<address>**—The IP address of the interface.

**<mask>**—The network mask for the interface.

---

**NOTE:** You must create a bridge group before creating the BVI.

---

For example, to create a bridge group, map the Ethernet interface to the bridge group, associate the bridge group with a BVI, assign an IP address to the BVI and enable the BVI IP address as a management interface for the system:

```
NSP1>ps
PS#configure
PS(NSP-config)#bridge addgroup 1
PS(NSP-config)#interface ethernet 0
PS(NSP-config-if)#bridge-group 1
PS(NSP-config-if)#exit
PS(NSP-config)#interface bvi 1
PS(NSP-config-bvi)#ip address 192.9.200.1 255.255.255.0
PS(NSP-config-bvi)#manage-intf enable
```

To **delete** a BVI use the following PS commands:

```
PS#configure
PS(NSP-config)#no interface bvi 1
```

To change the state of the BVI to “down”, use the following PS commands:

```
PS#configure
PS(NSP-config)#interface bvi 1
PS(NSP-config-bvi)#shutdown
```

## Configuration

### Assigning an IP Address to the BROADway System

---

To change the state of the BVI to “up”, use the following PS commands:

```
PS#configure
PS(NSP-config)#interface bvi 1
PS(NSP-config-bvi)#no shutdown
```

To *display* the status of the BVI, use the following PS command:

```
PS#show BVI status [bridge-group number]
```

If you specify an optional **[bridge-group number]**, only the BVI associated with the **[bridge-group number]** will be displayed. If you leave the **[bridge-group number]** field blank, all of the configured BVIs will be displayed.

The following sample output shows the **show BVI status** command results:

```
PS#show bvi status

BVI is configured for this bridge group
BVI is administratively enabled
MAC address of BVI is 00-02-35-00-ca-e8
```

## Management Access to the BROADway System

To further configure the **BROADway** system, you can access the unit through:

- A local connection to the serial port **SCP-1** using a command line interface
- A remote modem connection to the serial port **SCP-1** using a command line interface
- Either Ethernet interface **ETH-1** or **ETH-2** using Telnet and a command line interface
- Either Ethernet interface **ETH-1** or **ETH-2** using a web browser GUI interface

### Viewing Serial Craft Port Settings With the GUI

To view the configuration of the Serial Craft Port (SCP):

1. In the navigation tree, select either the **SCP-1** or **SCP-2** interface on an **NSP** card.
2. In the menu bar, click **Config**, then **Interface**.
3. Use the **SCP-1 RS232 Configuration** window to view the parameters for the SCP port. These fields are fixed and cannot be edited.
4. Click **Close** to close this window.

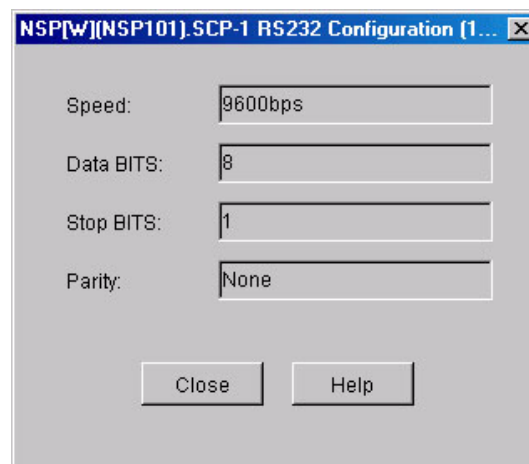

### Local SCP-1 Serial Craft Port Access

1. Connect to the **SCP-1** port directly and open a VT100 terminal emulation program. (For cabling information, see *Cabling the Serial Craft Port* on page 2-9.)
2. Press ENTER, and you should see the **NSP1>** or **NSP2>** prompt. Follow the instructions on page 3-13 to log into the system.

### Remote Modem SCP-1 Serial Craft Port Access

1. Connect a modem to the **SCP-1** directly using a modem cable and configure the modem appropriately. Follow the modem manufacturers instructions to set the modem for connection via RS232 at 9600bps, 8 data bits, no parity and one stop bit at the DTE port. The modem should be set to auto-answer incoming calls and local echo options should be disabled.

---

**NOTE:** It is particularly important to ensure that all local CONNECT messages and terminal echo options are disabled on the modem as these messages arriving at the **BROADway** system from a modem port can be interpreted as command line interface strings.

---

2. Dial in to the modem using a VT100 terminal emulation program and, once the modem has trained and answered you should be presented with the **NSP1>** or **NSP2>** prompt. Follow the instructions on page 3-13 to log into the system.

#### **Ethernet Port Command Line Access**

1. Connect your PC or workstation to one of the Ethernet ports (see *Cabling the Ethernet Port* on page 2-9) and open a Telnet session to the IP address of the **BROADway** system (e.g. 169.254.0.1).
2. You should be presented with the **LOGIN>** prompt. Use **CUSTOMER** for the user name and **BROADWAY** as the password.
3. If you are successfully logged in, you will be presented with the **NSP1>** or **NSP2>** prompt.
4. You can now configure the **BROADway** system using the CLI interface. Follow the instructions in *Logging In With the Command Line Interface (CLI)* on page 3-13 to learn how to log in and out of the system using the CLI or in *Setting Up User Accounts* on page 3-13.

---

**NOTE:** The **BROADway** system supports up to three simultaneous Telnet client sessions.

---

#### **Ethernet Port Web Browser GUI Access**

Connect your PC or workstation to one of the Ethernet ports on the **BROADway** and then follow the instructions found at *Logging In With the Web Browser Interface (GUI)* on page 3-9.



## Logging In With the Web Browser Interface (GUI)

You can access the **BROADway** GUI using these minimum versions of the Microsoft or Netscape web browsers:

- Netscape Communicator 4.6 and above with Java 1.3.0\_01 or later
- Microsoft Internet Explorer 5.0 and above with Java 1.3.0\_01 or later

When you initially connect to the **BROADway** system using the web browser interface, the system determines which version of Java you are running. If your Java software needs to be upgraded and your PC is connected to the Internet, the applet will download an updated version of Java software. If you are not connected to the Internet and you are notified that you need to upgrade your Java software, you can access and install it from the **BROADway** software CD. The U.S. English only version of the Java software is located on the CD in the /java/english directory, and the international version is located in the /java/international directory. Double-click the appropriate installer file (.exe) and follow the instructions the installer provides.

**NOTE:** The GUI interface is designed to operate as a Java applet that is self-contained within the **BROADway** system and downloaded to the PC-based browser interface when accessed. If the management PC is connected remotely to the **BROADway** system through a low-speed WAN connection (for example 64Kbps), then the applet might take several minutes to install.

To connect to the **BROADway** system using the GUI:

1. On your PC, open a web browser window.
2. Type the IP address or domain name of the **BROADway** system (for example, **http://192.168.5.10**, or **http://169.254.0.1**) and press ENTER.
3. To save time in the future, store the URL as an entry in the Favorites section of your browser.

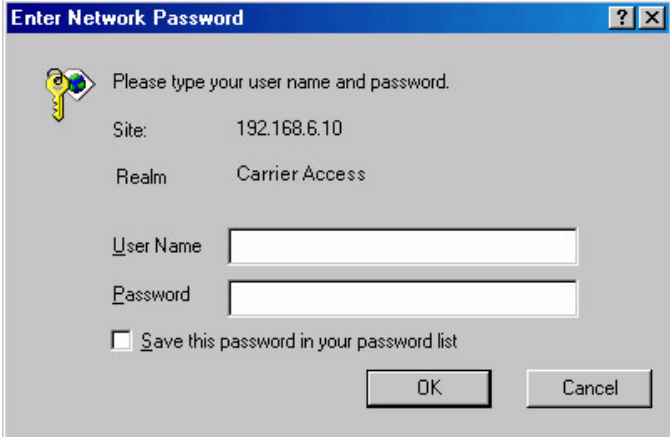

**NOTE:** If you are using Internet Explorer, the **Site** shown in the login window comes from the domain name of the system, and the **Realm** is always **Carrier Access**.

4. Type your user name in the **User Name** field, initially **CUSTOMER**.
5. Type your password in the **Password** field, initially **BROADWAY**.

**NOTE:** User names and passwords are case sensitive.

## Configuration

Logging In With the Web Browser Interface (GUI)

6. If the following message appears when the PC is loading the applet, then click the **Grant Always** button. This will enable the PC to download the applet certificate from the **BROADway** system and the message should not appear next time the applet is started.

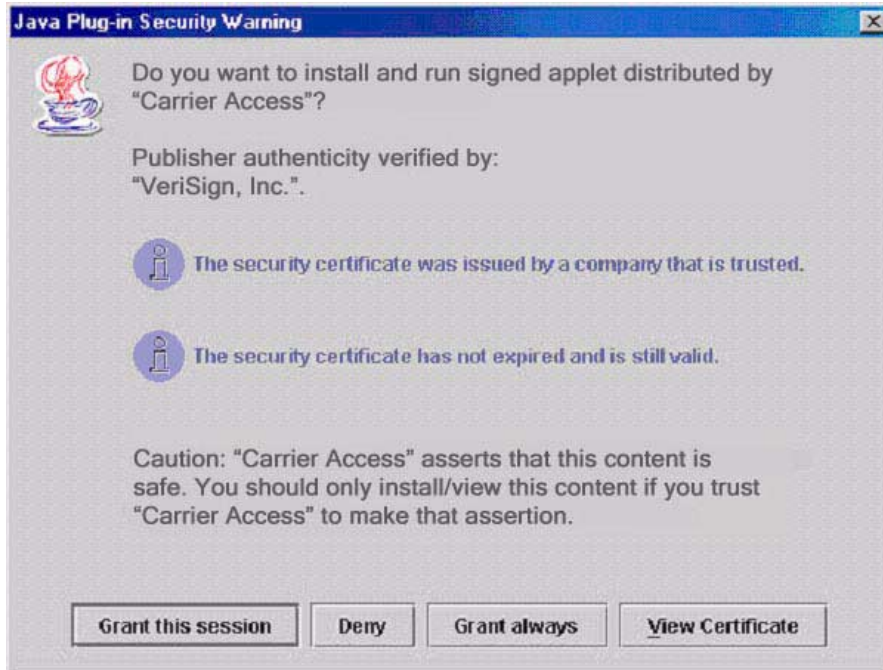

7. If the **BROADway** system to which you logged in is part of a stacked configuration, you will have the option of viewing just the one **BROADway** system you logged into, or the complete **BROADway** stack.
  - Select **Stack View** and click **OK** to see all the **BROADway** systems connected in a stack to this one **BROADway** system you logged into.
  - Select **Shelf View** and click **OK** to see only the **BROADway** system you logged into. The system will still remain part of the stack; but you will only be able to configure the one system.

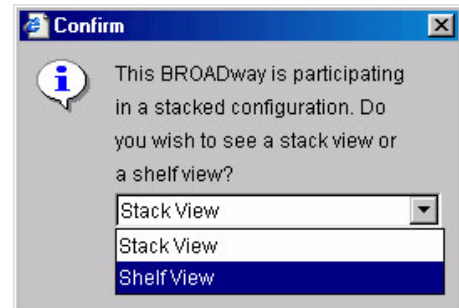

If there are any stacking problems, you will see messages that alert you to any stacking configuration problems when the GUI starts. You can correct these errors by removing the stacked systems in error, and then adding them back in.

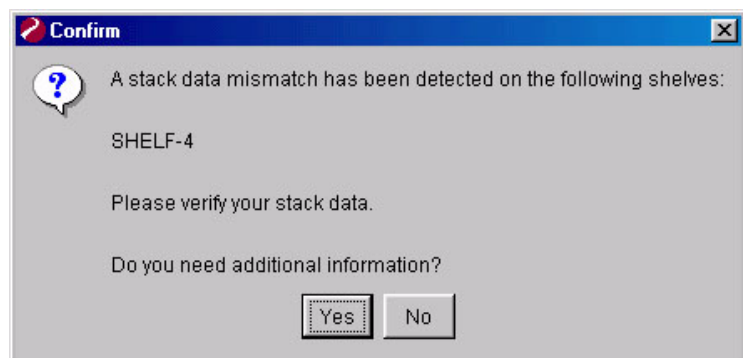

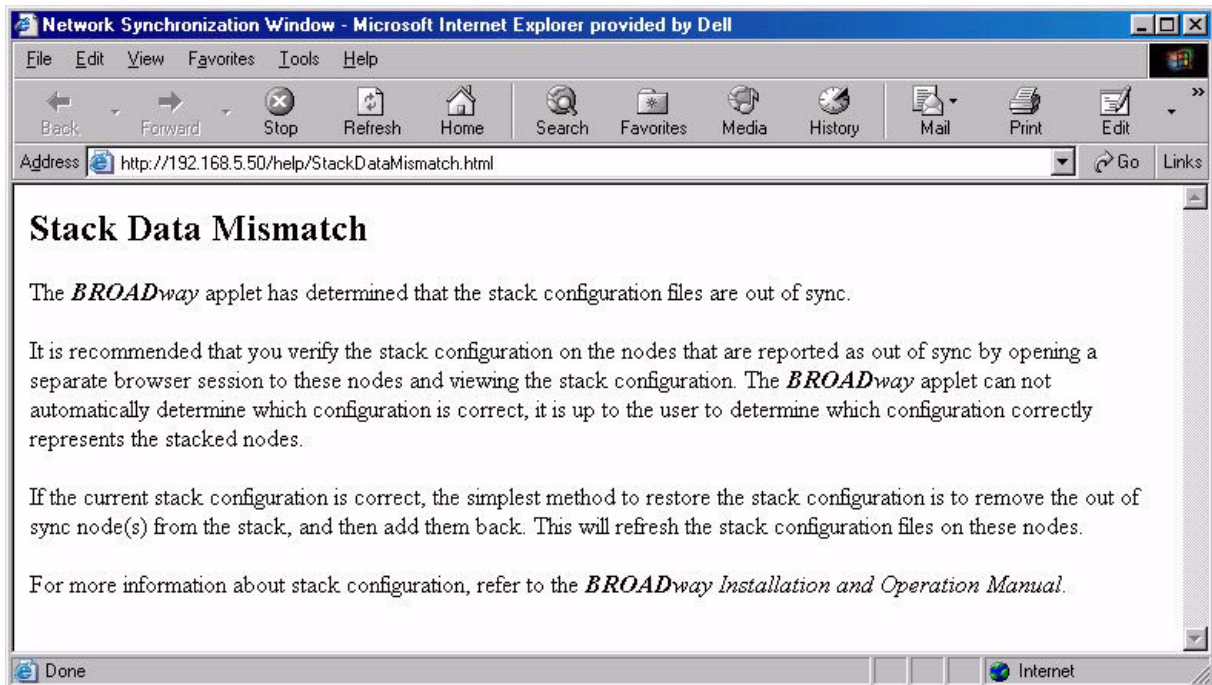

## Configuration

### Logging In With the Web Browser Interface (GUI)

- The browser window will change to reflect the **BROADway** configuration applet loader, and then you will be presented with the **BROADway** applet window as shown in the following figure.

Click here to minimize this window  
This window must remain running in the background

Click here to close the window and log off

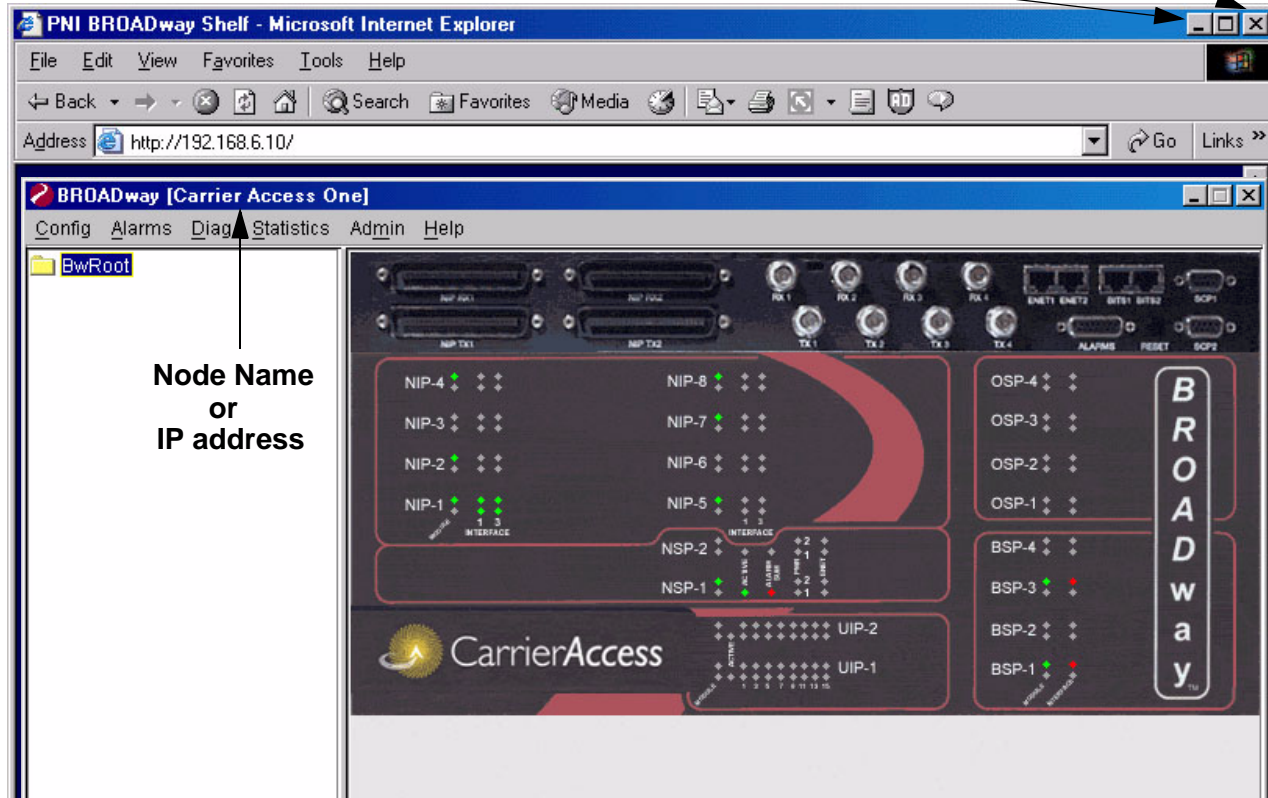

The **BROADway** applet window will show the name **BROADway** and then the system node name will be shown in parentheses. If you have not yet assigned a system node name or you kept the default system node name **BROADway**, the system IP address will be displayed.

You must leave the main browser window running in the background while the applet is operational. You can, however, minimize the window. Closing the main browser window will log you out and disconnect you from the **BROADway** system. You will have to log back in and restart the applet to continue managing the system.

**NOTE:** Up to three GUI sessions can be running on any single **BROADway** system. If a fourth client session attempts to connect to the system, the login will not complete and you will be presented with an error message.

To log out, click the **Close** button on the main browser window. If you accidentally close the applet window and the browser window is still open or minimized, you should close this window and restart the browser to log back into the **BROADway** system. Even though use of the **Refresh** button will appear to open up a new GUI window, problems can occur later on during the same session.

## Logging In With the Command Line Interface (CLI)

Once you have command line management access to the **BROAD**way system (you are at the **NSP1>** or **NSP2>** prompt), you can log in.

To log in to the **BROAD**way system using the command line interface use the following TL1 command:

```
ACT-USER::NSP:1234::<username>,<password>;
```

**<username>**—The name of the user account (default is **CUSTOMER**).

**<password>**—The account's password (default is **BROADWAY**).

---

**NOTE:** User names and passwords are case sensitive.

---

For example:

```
ACT-USER::NSP:1234::CUSTOMER,BROADWAY;
```

Alternatively, the following form of the ACT-USER command can be used:

```
ACT-USER::NSP:1234;
```

This version presents the user with a **LOGIN:** and **PASSWORD:** prompt, much like a Telnet login prompt. At the **PASSWORD:** prompt, the typed information is not echoed back to the screen for security purposes.

When you first log in to the **BROAD**way system, you will default to the TL1 command line interface. When you create and edit user accounts using TL1 commands you can specify the default command line interface (see *User Account Management Using TLI* on page 3-16).

Some configuration steps might only be performed with TL1 and some might only be performed with the packet services (PS) command line interface. Therefore, when performing configuration work using a CLI you might need to switch back and forth between TL1 and PS command shells.

You can tell which CLI you are currently using by looking at the terminal prompt. TL1 uses the **NSP1>** or **NSP2>** prompt. Packet services uses the **PS#** or **PS>** prompt (depending on your user permission level).

To switch to the **PS>** prompt from the **NSP>** prompt, type **ps** and press ENTER. To switch from the **PS>** prompt back to the TL1 **NSP>** prompt, type **exit** repeatedly until the **NSP>** prompt is displayed.

To log out from the **BROAD**way system using TL1, use the **CANC-USER** command:

```
CANC-USER::NSP:1234;
```

If you are accessing the **BROAD**way system from a Telnet client and your Telnet session times out, you will need to re-login using the **ACT-USER** command. Your Telnet session times out after approximately 10 minutes of no activity. If you log out using the **CANC-USER** command, you will need to use the **ACT-USER** command to log back in.

## Setting Up User Accounts

Some of the procedures described in this manual require a minimum permission level. All permission levels can view information associated with the **BROAD**way unit, but your permission level determines whether or not you can edit or change the configuration database for the system. The following table lists the permission levels that user accounts can be configured for and which commands that permission level can execute (in addition to just viewing current settings).

Permission Level	Description	GUI Menu Commands the Permission Level Can Execute Fully
Administrator	The administrative user level can execute all user commands. This is the only permission level that can add, edit and delete user accounts.	Every command under every menu
Configuration	The configuration level has access to all commands except adding, editing, or deleting users.	<b>Config</b> , (all) <b>Alarms</b> , (all) <b>Diag, Interface</b> <b>Statistics</b> , (all) <b>Admin, Database</b> <b>Admin, Password</b> <b>Help</b> , (all)
Maintenance	The maintenance level has execution permission on diagnostic and retrieve commands.	<b>Alarms</b> , (all) <b>Diag, Interface</b> <b>Statistics</b> , (all) <b>Admin, Password</b> <b>Help</b> , (all)
Reader	The reader level cannot execute any command except for viewing commands.	<b>Alarms</b> , (all) <b>Statistics</b> , (all) <b>Admin, Password</b> <b>Help</b> , (all)

Permission levels are cumulative. For example, users with Administrator security can perform all actions that users with Configuration security can. Users with Configuration security can perform all actions that users with Maintenance security can and users with Maintenance security can perform all actions that users with Reader security can.

Only a user with Administrator security level can add, edit, or delete user accounts.

To manage user accounts with the GUI, see *User Account Management Using the GUI* on page 3-15.

To manage user accounts from the CLI, see *User Account Management Using TLI* on page 3-16.

## User Account Management Using the GUI

To manage user accounts:

1. In the menu bar, click **Admin**, then **Accounts**.
2. The **Accounts** window displays a list of users that have access to the **BROADway** system and what their permission levels are. Review the user names and their security levels.
3. The first time you log into the **BROADway** system, you should create a new user account with an **Administrator** security level. Creating a new Administrator account will automatically delete the default user account: **CUSTOMER**.
4. Only Administrator level users can add, edit or delete user accounts. To **add** a new user:

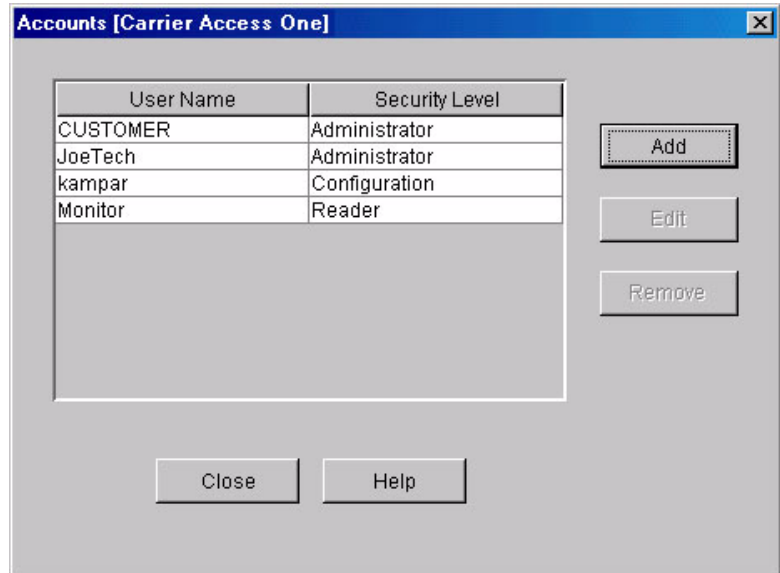

- Click **Add**.
  - In the **New User Account** window, type a new username up to 20 characters in the **User Name** field. This field is case sensitive. The system prevents you from creating two user accounts with the same user name.
  - Type a password of up to 10 characters in the **Password** field. This field is case sensitive. A user can change his own password later. See *Changing Your Password* on page 3-18.
  - In the **Confirm** field, re-type the password.
  - In the **Security** field, select the level of security you want this user to have (see page 3-14).
  - Click **OK** to close the **User Account** window.
5. To **edit** a user profile, select the user and click **Edit**.
  6. To **delete** a user profile, select the user and click **Remove**.
  7. Click **OK** to close the window.



## User Account Management Using TL1

### Viewing Existing User Accounts

To show all users that have accounts on the **BROAD**way system, use the following TL1 command:

```
RTRV-USER::NSP:1234::ALL;
```

To show all currently logged in users, use the following TL1 command:

```
RTRV-USER::NSP:1234::ACTIVE;
```

To show the name of the currently logged in user, use the following TL1 command:

```
RTRV-USER::NSP:1234::ME;
```

To show a particular user account, use this TL1 command:

```
RTRV-USER::NSP:1234::<username>;
```

### Creating New User Accounts

To create a new user, use the **ENT-USER** TL1 command:

```
ENT-USER::NSP:1234::<username>,<password>,<security>,<shell>;
```

**<username>**—The name of the user account (no longer than 20 characters).

**<password>**—The account's password.

---

**NOTE:** User names and passwords are case sensitive.

---

**<security>**—the security level to assign to this account, either **ADMIN**, **CONFIG**, **MAINT**, or **READER**.

**ADMIN**—The administrative user level can execute every TL1 command and PS command.

**CONFIG**—The configuration level has access to all commands except add, edit, or delete users.

**MAINT**—The maintenance level has execution permission on diagnostic and retrieve commands, as well as the ability to clear packet services table information.

**READER**—The reader level cannot execute any command except for retrieve and show commands.

**<shell>**—Indicates what the default command shell prompt is for this account, either **TL1** or **IPCLI** (for packet services).

---

**NOTE:** Regardless of what the default shell is for a user, the user can still switch between the TL1 prompt and the packet services (PS) prompt once the user logs in.

---



For example:

```
ENT-USER::NSP:1234::joetech,mypassword,ADMIN,TL1;
```

This command adds an account to the system where the username is *joetech*, the password is *mypassword*, the security level is *ADMIN* and the default shell is *TLI*.

For all TL1 commands, after performing an **ENT** or **ED** command (to add or edit information), you should always use the corresponding **RTRV** command to verify that your additions or changes were made correctly.

For example, after using the **ENT-USER** command to add users, use the **RTRV-USER::NSP:1234::ALL;** command to view all user accounts.

### **Editing User Accounts**

To edit a user's user name, password, and security level, use the **ED-USER** TL1 command:

```
ED-USER::NSP:1234::<username>,<password>,<security>,<shell>;
```

**<username>**—The name of the user account.

**<password>**—The account's password.

**<security>**—The security level to assign to this account, either **ADMIN**, **CONFIG**, **MAINT**, or **READER**.

**<shell>**—Indicates what the default command shell prompt is for this account, either **TL1** or **IPCLI** (for packet services).

### **Deleting User Accounts**

To delete a user, use the **DLT-USER** TL1 command:

```
DLT-USER::NSP:1234::<username>;
```

**<username>**—The name of the user account.

## Changing Your Password

A user can change his or her own password. Only users with Administrator privileges can change other users passwords.

---

**NOTE:** Passwords are case sensitive.

---

### Changing Your Password Using the GUI

To change your password from the GUI:

1. In the menu bar, click **Admin**, then **Password**. The **Change Password** screen shows your **User Name**.
2. In the **Current Password** field, type your current password.
3. In the **New Password** and **Confirm Password** fields, type your new password. Passwords are case sensitive and can be up to 10 characters.
4. Click **OK**. The next time you log in to the **BROADway** system, use your new password.

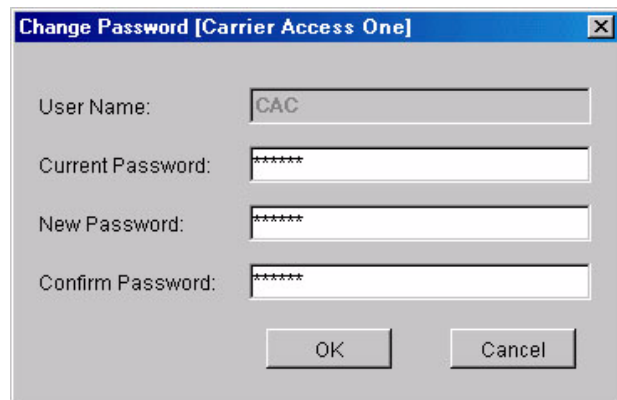

The screenshot shows a dialog box titled "Change Password [Carrier Access One]". It contains four input fields: "User Name" with the value "CAC", "Current Password" with six asterisks, "New Password" with six asterisks, and "Confirm Password" with six asterisks. At the bottom right, there are two buttons: "OK" and "Cancel".

### Changing Your Password Using TL1

To change your password from the command line, use the **ED-PID** TL1 command:

```
ED-PID::NSP:1234::<oldpassword>,<newpassword>;
```

**<oldpassword>**—your old password

**<newpassword>**—that new password

The next time you log in to the **BROADway** system, use your new password.

## Setting the System Date and Time

The **BROAD**way system maintains a real-time clock to assist in ensuring event and alarm times are properly recorded in the system. This section describes how to set the real-time clock from the GUI and command line interfaces.

### Setting the Date and Time Using the GUI

To set the date and time on the **BROAD**way system:

1. In the menu bar, click **Config**, then **Date & Time**.
2. In the **Date & Time** window, enter the date and time.
  - To set the **BROAD**way system to the same date and time as your workstation, click **Set to Today**.
  - Alternately, enter the date and time you require using the **Year**, **Month**, **Day**, **Hour**, and **Minute** fields.
3. Click **OK**.

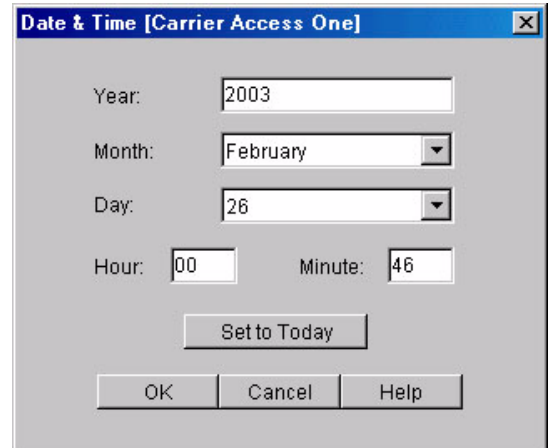

The screenshot shows a dialog box titled "Date & Time [Carrier Access One]". It has a standard Windows-style title bar with a close button. The dialog contains several input fields: "Year" with the value "2003", "Month" with a dropdown menu showing "February", "Day" with a dropdown menu showing "26", "Hour" with a spinner box showing "00", and "Minute" with a spinner box showing "46". Below these fields is a button labeled "Set to Today". At the bottom of the dialog are three buttons: "OK", "Cancel", and "Help".

### Setting the Date and Time Using TL1

To *view* the system date and time, use the **RTRV-DAT** TL1 command:

```
RTRV-DAT::NSP:1234::;
```

To *change* the system date and time, use the **ED-DAT** command:

```
ED-DAT::NSP:1234::YY-MM-DD,HH-MM-SS;
```

**YY-MM-DD**—The two-digit year, month, and day of the system date.

**HH-MM-SS**—The time (24-hour clock) of the system.

For example:

```
ED-DAT::NSP:1234::03-07-01,15-35-00;
```

This command changes the date to July 1, 2003 and the time to 3:35 PM.

## Setting System Node Parameters

System node parameters are system wide settings that enable the operator to configure various options such as: **BROAD**way location, the contact information of the system administrator and whether or not power redundancy is enabled.

### Setting System Node Parameters Using the GUI

1. In the menu bar, click **Config**, then **Node ID**.

The screenshot shows a dialog box titled "Node ID [Carrier Access One]". Inside, there is a section labeled "Unit Information" containing several input fields: "Node Name" with the value "Carrier Access One", "Admin Name" with "JoeTech", "Node Location" with "Brookfield", "Phone Number" with "12037403650", "System Mode" with a dropdown menu showing "U.S.", and "Email Address" with "joetech@abc.com". Below these fields is a checked checkbox labeled "Power Supply Redundancy". At the bottom of the dialog are three buttons: "OK", "Cancel", and "Help".

**NOTE:** If this is a stacked configuration, you must select a node or shelf name in the navigation tree before clicking **Node ID**; otherwise **Node ID** will be grayed out.

2. In the **Node ID** window, type a name for this site in the **Node Name** field.
3. In the **Node Location** field, type the location of this site.
4. In the **System Mode** field, select either **U.S.** or **International**, depending on where this site is located (for Canada, use the **U.S.** setting). This setting will determine your default interfaces (T1/SONET for U.S. and E1/SDH for International) for the various cards.

**NOTE:** If this system is participating in a stack, the system mode of each system in the stack should be the same.

5. In the **Admin Name** field, type the name of the administrator at this site.
6. In the **Phone Number** field, type the phone number of the administrator.
7. In the **Email Address** field, type the email address of the administrator.
8. The **Power Supply Redundancy** check box enables and disables power supply redundancy alarm reporting. If you have installed two separate power sources to the **BROAD**way chassis (both **FEED A** and **FEED B** on the back of the chassis), you should enable power supply redundancy by checking this check box. For information about connecting these power feeds, see *Cabling Power and Ground* on page 2-6. If you do not have two separate power sources connected to the chassis, you should disable power supply redundancy by clearing the check box; otherwise, the **NSP PWR** alarm LED will lamp red (as described in the online help).
9. Click **OK**.

## Setting System Node Parameters Using TL1

To view system data (such as system name and system location), use the **RTRV-UDATA** TL1 command:

```
RTRV-UDATA::NSP:1234;
```

To edit system node parameters, use the **ED-UDATA** TL1 command:

```
ED-UDATA::NSP:1234::NODE_NAME,<anystring>;  
ED-UDATA::NSP:1234::NODE_LOCATION,<anystring>;  
ED-UDATA::NSP:1234::ADMIN_NAME,<anystring>;  
ED-UDATA::NSP:1234::PHONE_NUMBER,<anystring>;  
ED-UDATA::NSP:1234::EMAIL_ADDRESS,<anystring>;  
ED-UDATA::NSP:1234::<system_mode>;
```

**<anystring>**—alphanumeric string of up to 20 characters that does not start with a number and contains no spaces or special characters

**<system\_mode>**—US or INT (for international)

### Examples:

Name the *BROAD*way node *systemOne*:

```
ED-UDATA::NSP:1234::NODE_NAME,systemOne;
```

Set the node location to *Brookfield*:

```
ED-UDATA::NSP:1234::NODE_LOCATION,Brookfield;
```

Set the administrator name to *JoeTech*:

```
ED-UDATA::NSP:1234::ADMIN_NAME,JoeTech;
```

Set the phone number of the administrator to *phone2037403650*:

```
ED-UDATA::NSP:1234::PHONE_NUMBER,phone2037403650
```

Set the email address of the administrator to *jtech@msn.com*:

```
ED-UDATA::NSP:1234::EMAIL_ADDRESS,jtech@msn.com;
```

Set the system mode to *U.S./Canada*:

```
ED-UDATA::NSP:1234::US;
```

---

**NOTE:** When you configure cards that can be T1 or E1, the interfaces on those cards will be set to T1 by default. Those that can be SONET or SDH will default to SONET.

---

Set the system mode to *International*:

```
ED-UDATA::NSP:1234::INT;
```

---

**NOTE:** When you configure cards that can be T1 or E1, the interfaces on those cards will be set to E1 by default, those that can be SONET or SDH will default to SDH.

---

After performing a TL1 **ENT** or **ED** command (to add or edit information), you should become used to using the corresponding **RTRV** command to verify that the changes were made correctly. For example, after using the **ED-UDATA** command to edit system data, use the **RTRV-UDATA::NSP:1234;** command to view system data.

## Configuration

### Setting System Node Parameters

---

To view the power input redundancy status of the system, use the **RTRV-EQPT** TL1 command:

```
RTRV-EQPT::NSP-x.PWR-1:1234;
```

To enable or disable power input redundancy, use the **ED-EQPT** TL1 command:

```
ED-EQPT::NSP:1234::<setting>;
```

**<setting>**—**ENA**, **ENABLE**, **ENABLED**, **DIS**, **DISABLE**, or **DISABLED**.

#### Examples:

Enable power supply input redundancy (assuming NSP-1 is the active NSP):

```
ED-EQPT::NSP:1234::ENA;
```

Disable power supply input redundancy (assuming NSP-1 is the active NSP):

```
ED-EQPT::NSP:1234::DIS;
```

If you have installed two separate power sources to the **BROADway** chassis (both **FEED A** and **FEED B** on the back of the chassis), you should enable power input supply redundancy. (For information about connecting these power feeds, see *Cabling Power and Ground* on page 2-6.) If you do not have two separate power sources connected to the chassis, you should disable power supply redundancy; otherwise, the **NSP PWR** alarm LED will lamp red (as described in the online help).

## Managing the BROADway Configuration Database

**BROADway** stores all configuration information in a database located in the non-volatile (flash) memory-based file system in both the primary and backup (if installed) NSP101 cards. Changes made to the database on the primary (in-service) NSP101 card are automatically copied and synchronized with the database on the backup (out-of-service) NSP101 card.

**BROADway**'s flash file system has approximately 30 MB available for system and user data, including databases and code images. You can have as many database configurations stored as allowed up to the limit of the **BROADway** file system storage space. If you use up all the available flash file system memory, then when you attempt to save or copy a database the operation will fail.

---

**NOTE:** If your flash file system begins to run out of space, the **ALARM SUM** LED on the NSP101 will light. To recover from the alarm condition, delete any unneeded files. If you ignore the alarm, the **BROADway** system will degrade in management access performance.

---

Each of the configuration databases stored in the **BROADway** system will fall into one of the following three categories:

**RUNNING**—The “running” database is the one that the **BROADway** system is currently executing and running. Only one database can be “running” at any one time in the **BROADway** system.

**SAVED**—The “saved” database is the one that will come into effect when you reboot the **BROADway** system. Only one database can be a “saved” database.

**OFFLINE**—All other databases that were ever named and stored but are not either **RUNNING** or **SAVED** are off-line databases. You can have as many off-line databases as your **BROADway** system's memory allows. If you use up all memory then when you attempt to store or copy a new database, the operation will fail.

---

**NOTE:** It is important to note that configuration changes made in the course of normal operation to the **RUNNING** database will not be automatically saved unless a command is performed to save the current configuration to the **SAVED** or other offline database. If you reboot the **BROADway** system without saving any configuration changes made to the **RUNNING** configuration then **BROADway** will revert to the previously **SAVED** database.

---

The **BROADway** management interface will enable you to:

- Load and execute a different database than the one currently running
- Make a backup copy of a database
- Delete a database
- Rename a database

### Managing the Database Using the GUI

To modify the configuration database status using the GUI interface:

1. In the menu bar, click **Admin**, then **Database**.
2. The **Database Management** window will appear. Review which databases are currently in the **RUNNING**, **SAVED**, and **OFFLINE** states.

**NOTE:** To change the currently **RUNNING** database to a previously stored configuration, you must reboot the **BROADway** system. You cannot move a database directly into the **Running** folder. You can only move a database into the **Saved** folder. When you reboot the **BROADway** system, the database in the **Saved** folder becomes the **RUNNING** database.

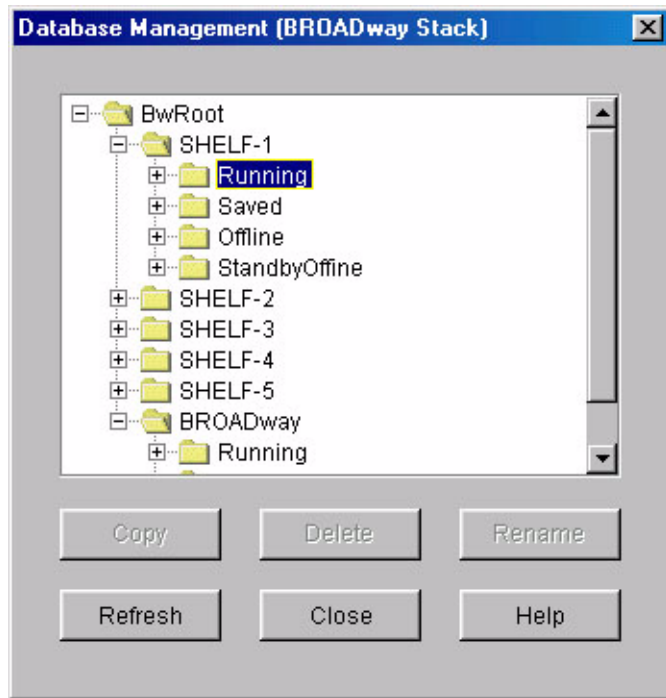

3. To **select** the current **RUNNING** database or an **OFFLINE** database as the **SAVED** database:
  - Select the database that you want to move to **SAVED**. Click **Copy**.
  - In the **To** field, select **Saved**.
  - If you want to change the name of the database (from that shown in the **From** field), type a new name in the box under the **Saved** field.
  - Click **OK**.

**NOTE:** Database names are limited to 19 characters and must not begin with a numeric character.

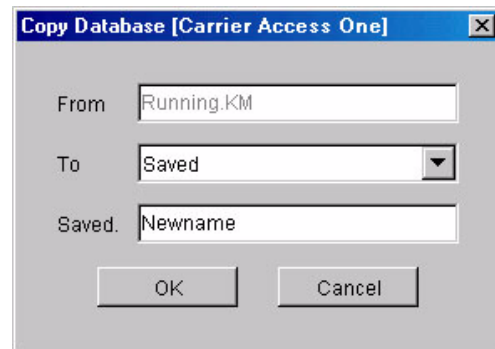



4. To *delete* a database, select it under **Offline** and click **Delete**. You cannot delete the database that is either **RUNNING** or **SAVED**. To delete a database that is **RUNNING** or **SAVED**, you must copy an alternative database file to **SAVED**.
5. To rename a database, select it and click **Rename**.
6. Click **Close** to close the **Database Management** window.

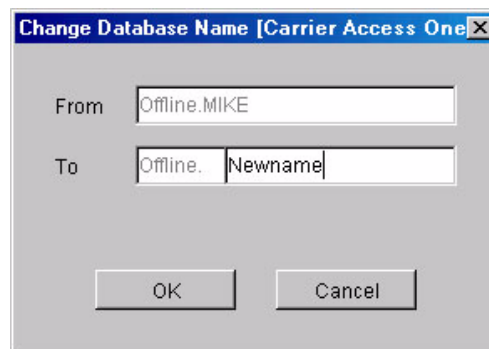

To *re-initialize* the database system to a default factory condition, follow the instructions found in *Managing the Database Using TL1* on page 3-25.

### Managing the Database Using TL1

To *view* the databases currently stored on the **BROADway** system, use the **RTRV-DB TL1** command:

```
RTRV-DB::NSP:1::;
```

To *copy* the **RUNNING**, **SAVED**, or an **OFFLINE** configuration database to the **SAVED**, or an alternative **OFFLINE** database, use the **CPY-DB TL1** command:

```
CPY-DB::NSP:1::<fromname>,<toname>,<newname>;
```

<fromname>—**RUNNING**, **SAVED**, or user-defined **OFFLINE** name.

<toname>—**SAVED**, or user-defined **OFFLINE** name.

<newname>—User-defined saved name. This field is optional and should only be specified when <fromname> is **RUNNING** and <toname> is **SAVED**.

**NOTE:** Database names are limited to 19 characters and must not begin with a numeric character.

#### Examples:

Save the running database to the **SAVED** database as the filename *newdbname*:

```
CPY-DB::NSP:1::RUNNING,SAVED,newdbname;
```

The next time you reboot the **BROADway** system, this database will become the **RUNNING** database.

Create an **OFFLINE** copy of the saved database under the filename *offlinename*:

```
CPY-DB::NSP:1::SAVED,offlinename;
```

Copy the database named *offlinename* as the **SAVED** database:

```
CPY-DB::NSP:1::offlinename,SAVED;
```

The next time you reboot the **BROADway** system, this database will become the **RUNNING** database.

**NOTE:** To change the currently running configuration, you must reboot the **BROADway** system. You cannot move a database directly to **RUNNING**. You can only move a database to **SAVED**. When you reboot the **BROADway** system, the database in **SAVED** becomes the **RUNNING** database.

## Configuration

### Managing the *BROADway* Configuration Database

---

To *delete* an **OFFLINE** database, use the **DLT-DB** TL1 command:

```
DLT-DB::NSP:1234::<name>;
```

<name>—User defined **OFFLINE** database name.

#### Examples:

Delete the database called *offlinename* from the active NSP:

```
DLT-DB::NSP:1234::offlinename;
```

Delete the database called *offlinename* from NSP-1:

```
DLT-DB::NSP-1:1234::offlinename;
```

Deletes the database called *offlinename* from NSP-2:

```
DLT-DB::NSP-2:1234::offlinename;
```

You cannot delete the database that is either currently stored as **RUNNING** or **SAVED**.

To *initialize* the database system to its factory default, use the **INIT-DB** TL1 command:

```
INIT-DB::NSP:1234;
```

After you initialize the database, reboot the *BROADway* system using the **INIT-SYS** TL1 command (see page 3-27).

---

**CAUTION!** USE THE **INIT-DB** COMMAND WITH EXTREME CARE AS IT WILL RESET THE **SAVED** CONFIGURATION DATABASE TO A FACTORY DEFAULT STATE. ENSURE YOU HAVE A BACKUP OF ANY PREVIOUS SAVED CONFIGURATION BEFORE YOU EXECUTE THIS COMMAND.

---

## Exporting the *BROADway* Database to a TL1 Script

The *BROADway* embedded database is designed to offer fast access to each configuration element of the *BROADway* switch. However, it is not stored in a simple human-readable format. To dump the contents of the database to a TL1 script format, the following TL1 commands can be used:

```
EXEC-SYS::NSP:1234::cfgDumpTL1;
```

```
EXEC-SYS::NSP:1234::cfgDumpTL1verbose;
```

The **EXEC-SYS** command accesses each element configuration table within the database in turn and converts the contents to a series of TL1 commands. The first variant of the command will only print information that is changed from the default switch settings. The second variant of the command will print the entire database as a series of TL1 commands.

In this release of the system software, the output is sent to the console from which the command was executed, i.e. the serial craft port or a Telnet session. An operator using a terminal emulation program such as Hyperstream can capture the output from the switch to a file on the local PC, and replay it back to the switch to configure the product.

It is also possible to capture the output, modify certain script parameters and then play it back to replicate a single configuration easily on multiple *BROADway* switches.

## Copying Files Between NSP101 Controllers

On some occasions, it might be useful to copy files from the working NSP101 controller to the protection, or backup, controller (for example, to copy scripts for Node Level APS support). Copying files between NSP101 modules is accomplished using the **file-sync** TL1 command:

```
NSP1> file-sync::nsp:1234::FLASH/SCRIPTS/tlswitch.scp;
Sending file /FLASH/SCRIPTS/tlswitch.scp to peer NSP
2003-04-10 08:05:32
M 1234    COMPLD
NSP-1,
;
```

## Re-Starting the *BROADway* System Using TL1

You can restart one or both of the NSP101 control cards in a *BROADway* system using the **INIT-SYS** TL1 command:

```
INIT-SYS::<aid>:1234::{FORCE|ALL};
```

<aid>—One of the following:

**NSP-1**—Resets the NSP101 in slot NSP-1, regardless of whether or not it is the active NSP101.

**NSP-2**—Resets the NSP101 in slot NSP-2, regardless of whether or not it is the active NSP101.

**NSP**—Resets the active NSP101.

**NSP-P**—Resets the non-active (protection) NSP101.

**FORCE**—Forces a reboot of the specified NSP card.

**ALL**—Resets both NSP101s.

---

**CAUTION!** USE THE **INIT-SYS** COMMANDS WITH EXTREME CARE AS THESE COMMANDS WILL POTENTIALLY PERFORM A SERVICE-AFFECTING RESTART OF THE *BROADway* SYSTEM.

---

### Examples:

Restart the working NSP (switches *BROADway* to redundant NSP only if installed):

```
INIT-SYS::NSP:1234::FORCE;
```

Restart the working NSP (switches *BROADway* to redundant NSP only if installed):

```
INIT-SYS::NSP-1:1234::FORCE;
```

Restart the protection NSP if installed:

```
INIT-SYS::NSP-2:1234::FORCE;
```

Restart the protection NSP if installed:

```
INIT-SYS::NSP-P:1234::FORCE;
```

## Configuration

### Using FTP with the BROADway System

---

Restart both NSP101 control cards in a redundant configuration. (*This is a service affecting reboot.*)

```
INIT-SYS::NSP:1234::ALL;
```

---

**CAUTION!** WHEN **BROADWAY** DATABASES ARE SYNCHRONIZING BETWEEN THE ACTIVE AND STANDBY **NSP101** CARDS, YOU WILL NOTICE THAT THE **ACTIVE LEDs** ON THE **NSP101S** WILL BLINK RAPIDLY TO SIGNIFY A FILE TRANSFER IS IN PROGRESS. YOU MUST WAIT UNTIL THESE **LEDs** HAVE STOPPED FLASHING BEFORE YOU PERFORM ANY OPERATION TO RE-INITIALIZE THE **BROADWAY** SYSTEM EITHER THROUGH A REBOOT OR FORCED **NSP101** PROTECTION SWITCHOVER.

---

## Using FTP with the BROADway System

The **BROADway** system operates an FTP server for the purpose of quickly uploading and downloading files to and from the node. Information such as system software updates, system and alarm logs and the node database can be transferred using the FTP protocol.

**BROADway** has two disks mounted that can be accessed with FTP, these are /FLASH and /VDISK. The former is a silicon disk mounted in non-volatile memory, while the latter is a silicon disk mounted temporarily in working RAM. Information stored in /FLASH will be saved over a reboot of the system while that in /VDISK will be lost once the **BROADway** unit is restarted. /FLASH is the default folder for an FTP session.

The following log is an example of an FTP session that logs into a **BROADway** system, changes folder to the System Logs folder on the /FLASH disk and copies the SYSLOG binary file to the local PC.

```
ftp> open 192.168.5.60
Connected to 192.168.5.60.
220 VxWorks (5.4.2) FTP server ready
User (192.168.5.60:(none)): ADMIN
331 Password required
Password:
230 User logged in
ftp> cd /FLASH/logfiles
250 Changed directory to "/FLASH/logfiles"
ftp> bin
200 Type set to I, binary mode
ftp> get SYSLOG c:\syslog
200 Port set okay
150 Opening BINARY mode data connection
226 Transfer complete
ftp: 120240 bytes received in 0.52Seconds 230.79Kbytes/sec.
ftp> disconnect
221 Bye...see you later
```

FTP can be used to retrieve information that can be useful to Carrier Access in debugging problems that have been experienced on the system, or for uploading new system software releases to the **BROADway** system. Remember that all filenames are case sensitive in the FTP protocol.

## **Upgrading System Software**

Periodically, Carrier Access releases new versions of the software that operates the **BROADway** system. When you receive the software, you must FTP the system files to the **BROADway** NSP101 which implies that you must have an IP address configured for the Ethernet interface of the system (see *Assigning an IP Address to the BROADway System* on page 3-3). When FTPing files to the **BROADway** system, you are required to enter a username and password with either Configuration or Administrator privileges.

For specific details on how to upgrade the system software using FTP, refer to the official Release Notes for that software release. The following procedure might be superseded by the system Release Notes.

Upgrading system software tasks can only be performed through the TL1 command line interface.

To upgrade the system software to release 3.08 from an earlier software release, follow these instructions:

1. Verify the release of software currently running on your **BROADway** system by executing the following TL1 command:

```
rtrv-sw-ver::nsp:1234::all;
```

Both NSP101 modules should be running the same version of **BROADway** system code:

```
NSP1> rtrv-sw-ver::nsp:1234::all;  
2003-04-08 10:43:20  
M 99    COMPLD  
NSP-1,  
Working NSP BROADway SW Version: 3.04  
Protection NSP BROADway SW Version: 3.04
```

2. Copy the new software release to the PC from which you will be running the FTP upload session. For this example, we assume the file, *bw308.zip*, has been copied to the C:\TEMP folder.

## Configuration

### Upgrading System Software

---

3. Use an FTP client program to open an FTP session to the **BROAD**way node and upload the system software file to the /FLASH folder. This example shows the standard Microsoft Windows FTP client. The upload time might be more than several minutes if the IP connection to the **BROAD**way node is over a low-speed WAN link:

```
c:\>ftp 192.168.5.60
Connected to 192.168.5.60.
220 VxWorks (5.4.2) FTP server ready
User (192.168.5.60:(none)): ADMIN
331 Password required
Password:
230 User logged in
ftp> cd /FLASH
250 Changed directory to "/FLASH"
ftp> bin
200 Type set to I, binary mode
ftp> put c:\temp\bw308.zip
200 Port set okay
150 Opening BINARY mode data connection
226 Transfer complete
ftp: 4664234 bytes sent in 124.73Seconds 37.40Kbytes/sec.
ftp> bye
221 Bye...see you later
```

4. To complete the software upgrade, use the **set-upgrade** command to decompress the software image, copy it to the backup NSP101 and reboot the **BROADway** system:

```
NSP1> set-upgrade::nsp:1234::bw308,all;
Sending file /FLASH/bw308.zip to peer
NSP.....
SET-BOOT bw308 command executing in peer
NSP.....
SET-BOOT bw308 command executing in local NSP
INIT-SYS command executing in peer NSP
/* LOCAL SYSTEM REBOOTING */
      2003-04-08 12:58:42
M 99   COMPLD
NSP-1,
;
```

---

**CAUTION!** THE SET-UPGRADE COMMAND CAUSES THE SYSTEM TO AUTOMATICALLY REBOOT FROM THE SOFTWARE IMAGE SPECIFIED IN THE COMMAND LINE. THIS IMAGE MUST HAVE PREVIOUSLY BEEN DOWNLOADED USING FTP TO THE FLASH MEMORY ON THE **BROADway** SYSTEM. SET-UPGRADE AUTOMATICALLY UNZIPS THE SOFTWARE IMAGE INTO THE EXECUTABLE APPLICATION FILES THAT THE **BROADway** SYSTEM WILL USE TO OPERATE.

---

To upgrade a **BROADway** system with a single NSP only, use the following format for the **set-upgrade** command:

```
NSP1> set-upgrade::nsp:1234::bw308;
SET-BOOT bw308 command executing in local NSP
/* LOCAL SYSTEM REBOOTING */
      2003-04-08 10:52:29
M 99   COMPLD
NSP-1,
```

---

**CAUTION!** THE SET-UPGRADE COMMAND CAUSES THE SYSTEM TO AUTOMATICALLY REBOOT FROM THE SOFTWARE IMAGE SPECIFIED IN THE COMMAND LINE. THIS IMAGE MUST HAVE PREVIOUSLY BEEN DOWNLOADED USING FTP TO THE FLASH MEMORY ON THE **BROADway** SYSTEM. SET-UPGRADE AUTOMATICALLY UNZIPS THE SOFTWARE IMAGE INTO THE EXECUTABLE APPLICATION FILES THAT THE **BROADway** SYSTEM WILL USE TO OPERATE.

---

## **Rolling Back a Software Update**

Should you want to reload a previous software version into the **BROAD**way system, the process is the same as the one previously outlined, but with one exception. When FTPing the system software file to the **BROAD**way unit, save the file to the /VDISK folder rather than the /FLASH folder. From release 3.08 onwards, software upgrades operate out of working RAM rather than Flash memory. For example:

```
c:\>ftp 192.168.5.60
Connected to 192.168.5.60.
220 VxWorks (5.4.2) FTP server ready
User (192.168.5.60:(none)): ADMIN
331 Password required
Password:
230 User logged in
ftp> cd /VDISK
250 Changed directory to "/VDISK"
ftp> bin
200 Type set to I, binary mode
ftp> put c:\temp\bw304.zip
200 Port set okay
150 Opening BINARY mode data connection
226 Transfer complete
ftp: 4664234 bytes sent in 124.73Seconds 37.40Kbytes/sec.
ftp> bye
221 Bye...see you later
```

## **Upgrading the Boot ROM**

Occasionally, system software releases will be accompanied by a firmware update to the Boot ROM on the NSP101 module. The minimum boot ROM revision required for system release 3.08 is version 1.6. The current revision number is available on the startup screen during the **BROAD**way boot cycle or through the use of the **exec-sys** TL1 command:

```
NSP1> exec-sys::nsp:1234::vers;
BROADway version: 3.04
PS version: 3.04
DATABASE version: 2.1
BSP Version : 1.60
value = 26 = 0x1a
2003-04-24 10:19:56
M 1234 COMPLD
NSP-1,
;
```



1. Once the new system software has been loaded and the **BROAD**way units have rebooted and synchronized (see *Upgrading System Software* on page 3-29), use the **exec-sys** TL1 command to update the Boot ROM on the working NSP:

```
NSP1> exec-sys::nsp:1234::bootUpdate;  
Starting to program bootrom...done  
value = 0 = 0x0  
      2003-04-08 11:06:21  
M 1    COMPLD  
NSP-1,
```

2. Next, reboot the working NSP101 using the **init-sys** command. If only a single NSP101 is present this will reboot the **BROAD**way system, if two are present then the **BROAD**way will switch to the protection NSP101 module:

```
NSP1> init-sys::nsp:1234::FORCE;  
/* LOCAL SYSTEM REBOOTING */  
      2003-04-08 11:08:16  
M 1234  COMPLD  
NSP-1,
```

3. Verify that, in a protected system, the backup NSP101 is in-service and synchronized, then perform a similar Boot ROM upgrade and reboot on the backup card:

```
NSP1> exec-sys::nsp:1234::bootUpdate;  
Starting to program bootrom...done  
value = 0 = 0x0  
      2003-04-08 11:06:21  
M 1    COMPLD  
NSP-1,
```

```
NSP1> init-sys::nsp:1234::FORCE;  
/* LOCAL SYSTEM REBOOTING */  
      2003-04-08 11:08:16  
M 1234  COMPLD  
NSP-1,
```

4. Ensure that the NSP101 switched back to the original working card. Both NSP101's are now upgraded to the new Boot ROM firmware version.

## TL1 Software Upgrade Commands

To display the *version* of system software running on your *BROADway*, use the **RTRV-SW-VER** TL1 command:

```
RTRV-SW-VER::<aid>:1234::ALL;
```

<aid>—NSP-1, NSP-2, or NSP (for both NSPs).

### Examples:

Display the *BROADway* software version loaded on NSP-1:

```
RTRV-SW-VER::NSP-1:1234::;
```

Display the *BROADway* software version number loaded on both NSPs:

```
RTRV-SW-VER::NSP:1234::ALL;
```

To *change* the executable system software image on the *BROADway* system, use the **SET-UPGRADE** TL1 command:

```
SET-UPGRADE::<aid>:1234::<filename>,ALL;
```

<aid>—NSP-1, NSP-2, or NSP (for both NSPs).

<filename>—The name of the new system software image file.

### Examples:

Load the *BROADway* software on NSP-1 with the file *bw308* (Release 3.08):

```
SET-UPGRADE::NSP-1:1234::bw308;
```

Load the *BROADway* software on both NSPs with the file *bw308* (Release 3.08):

```
SET-UPGRADE::NSP:1234::bw308,ALL;
```

---

**CAUTION!** THE **SET-UPGRADE** COMMAND CAUSES THE SYSTEM TO AUTOMATICALLY REBOOT FROM THE SOFTWARE IMAGE SPECIFIED IN THE COMMAND LINE. THIS IMAGE MUST HAVE PREVIOUSLY BEEN DOWNLOADED USING **FTP** TO THE FLASH MEMORY ON THE *BROADWAY* SYSTEM. **SET-UPGRADE** AUTOMATICALLY UNZIPS THE SOFTWARE IMAGE INTO THE EXECUTABLE APPLICATION FILES THAT THE *BROADWAY* SYSTEM WILL USE TO OPERATE.

---

# APPENDIX **A**

---

## ***Ports and Cables***

### **In This Appendix**

- Overview
- SCP-1 and SCP-2 Connector Pinouts
- ETH-1 and ETH-2 Connector Pinouts
- CKIN-1 and CKIN-2 Connector Pinouts (BITS Only)
- NIP400 Connector Pinouts (NIP TX1–RX1, NIP TX2–RX2)
- ALARMS Connector Pinouts
- NHP160 Connector Pinouts

## Overview

This appendix contains information about the ports on the **BROAD**way chassis and the cables used with the **BROAD**way chassis.

## SCP-1 and SCP-2 Connector Pinouts

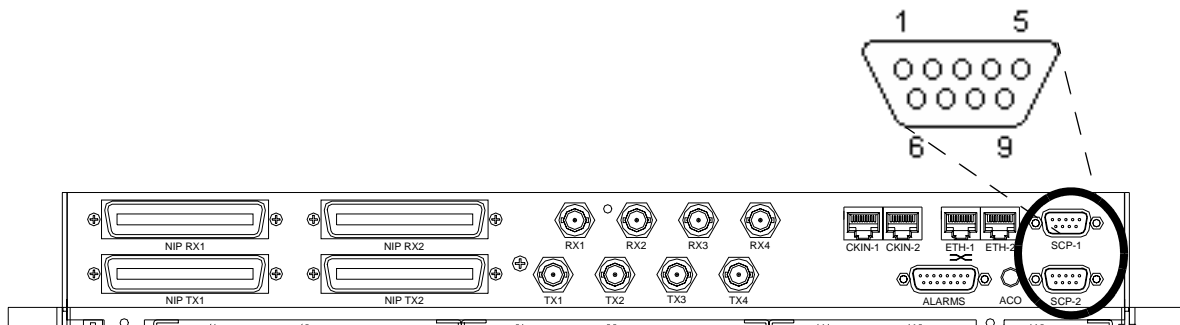

**SCP-1** and **SCP-2** are male, DB9 ports. These ports are asynchronous RS232 craft ports operating at 9.6 Kbps (EIA RS232 compliant). You use **SCP-1** for direct access using a terminal emulation program, such as HyperTerminal; **SCP-2** is for future use.

These are the pinouts for the **SCP-1** and **SCP-2** ports.

SCP-1			SCP-2 (future use)		
Pin	Signal	Name	Pin	Signal	Name
1			1	CD	Carrier Detect
2	RD	Receive Data	2	RD	Receive Data
3	TD	Transmit Data	3	TD	Transmit Data
4		Data Terminal Ready	4	DTR	Data Terminal Ready
5	GND		5	GND	
6		Data Set Ready	6	DSR	Data Set Ready
7		Request to Send	7	RTS	Request to Send
8		Clear to Send	8	CTS	Clear to Send
9		Ring Indicator	9	RI	Ring Indicator

## **ETH-1 and ETH-2 Connector Pinouts**

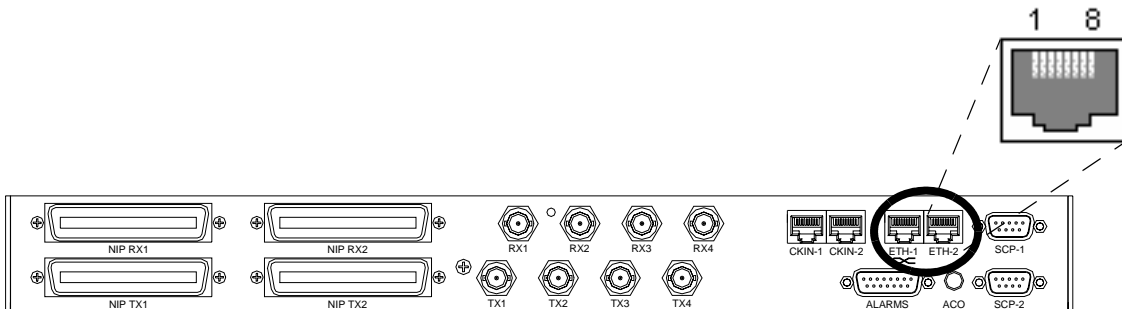

**ETH-1** and **ETH-2** are female, 10-BaseT, RJ45 ports (IEEE 802.3 compliant). They are identical, except that their transmit and receive pairs are reversed. These are the pinouts for the **ETH-1** and **ETH-2** ports.

<b>ETH-1</b>		<b>ETH-2</b>	
<b>Pin</b>	<b>Signal</b>	<b>Pin</b>	<b>Signal</b>
1	Receive +	1	Transmit +
2	Receive -	2	Transmit -
3	Transmit +	3	Receive +
4	nc	4	nc
5	nc	5	nc
6	Transmit -	6	Receive -
7	nc	7	nc
8	nc	8	nc

## Ports and Cables

### CKIN-1 and CKIN-2 Connector Pinouts (BITS Only)

## CKIN-1 and CKIN-2 Connector Pinouts (BITS Only)

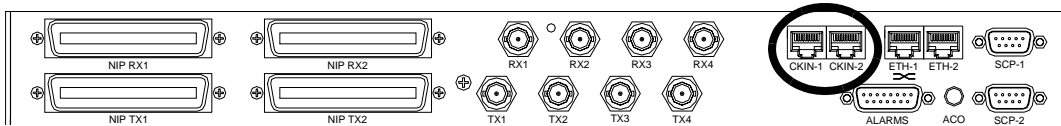

On the BITS version of the chassis, **CKIN-1** and **CKIN-2** are female, RJ45 ports (Bellcore specification GR-1244). These are the pinouts for the **CKIN-1** and **CKIN-2** ports.

CKIN-1		CKIN-2	
Pin	Signal	Pin	Signal
1	Receive -	1	Receive -
2	Receive +	2	Receive +
3	nc	3	nc
4	nc	4	nc
5	nc	5	nc
6	nc	6	nc
7	nc	7	nc
8	nc	8	nc

## NIP400 Connector Pinouts (NIP TX1–RX1, NIP TX2–RX2)

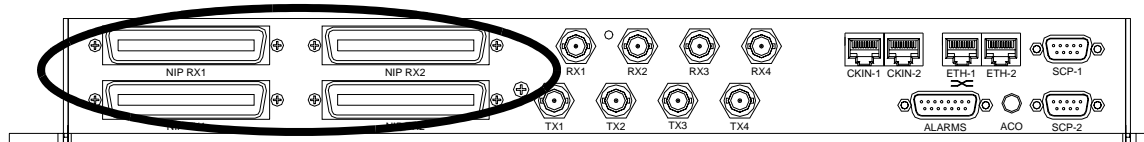

NIP TX1, NIP RX1, NIP TX2, and NIP RX2 are male 25 pair connections.

T1/E1 Circuit	NIP400 Card	TX tip	TX ring	RX tip	RX ring
		<b>NIP TX1</b>		<b>NIP RX1</b>	
1	NIP-1	26 white/blue	1 blue/white	26 white/blue	1 blue/white
2		27 white/orange	2 orange/white	27 white/orange	2 orange/white
3		28 white/green	3 green/white	28 white/green	3 green/white
4		29 white/brown	4 brown/white	29 white/brown	4 brown/white
5	NIP-2	30 white/slate	5 slate/white	30 white/slate	5 slate/white
6		31 red/blue	6 blue/red	31 red/blue	6 blue/red
7		32 red/orange	7 orange/red	32 red/orange	7 orange/red
8		33 red/green	8 green/red	33 red/green	8 green/red
9	NIP-3	34 red/brown	9 brown/red	34 red/brown	9 brown/red
10		35 red/slate	10 slate/red	35 red/slate	10 slate/red
11		36 black/blue	11 blue/black	36 black/blue	11 blue/black
12		37 black/orange	12 orange/black	37 black/orange	12 orange/black
13	NIP-4	38 black/green	13 green/black	38 black/green	13 green/black
14		39 black/brown	14 brown/black	39 black/brown	14 brown/black
15		40 black/slate	15 slate/black	40 black/slate	15 slate/black
16		41 yellow/blue	16 blue/yellow	41 yellow/blue	16 blue/yellow
		<b>NIP TX2</b>		<b>NIP RX2</b>	

## Ports and Cables

NIP400 Connector Pinouts (NIP TX1–RX1, NIP TX2–RX2)

T1/E1 Circuit	NIP400 Card	TX tip	TX ring	RX tip	RX ring
17	NIP-5	26 white/blue	1 blue/white	26 white/blue	1 blue/white
18		27 white/orange	2 orange/white	27 white/orange	2 orange/white
19		28 white/green	3 green/white	28 white/green	3 green/white
20		29 white/brown	4 brown/white	29 white/brown	4 brown/white
21	NIP-6	30 white/slate	5 slate/white	30 white/slate	5 slate/white
22		31 red/blue	6 blue/red	31 red/blue	6 blue/red
23		32 red/orange	7 orange/red	32 red/orange	7 orange/red
24		33 red/green	8 green/red	33 red/green	8 green/red
25	NIP-7	34 red/brown	9 brown/red	34 red/brown	9 brown/red
26		35 red/slate	10 slate/red	35 red/slate	10 slate/red
27		36 black/blue	11 blue/black	36 black/blue	11 blue/black
28		37 black/orange	12 orange/black	37 black/orange	12 orange/black
29	NIP-8	38 black/green	13 green/black	38 black/green	13 green/black
30		39 black/brown	14 brown/black	39 black/brown	14 brown/black
31		40 black/slate	15 slate/black	40 black/slate	15 slate/black
32		41 yellow/blue	16 blue/yellow	41 yellow/blue	16 blue/yellow

Pin 50 on connectors #1, #2, #3, and #4 is a drain wire connected to chassis ground.

As the pinouts show, if you are not installing NIP400 cards in NIP-5 through NIP-8, you do not need to connect the ports **NIP TX2** and **NIP RX2**. Likewise, if you are not installing NIP400 cards in NIP-1 through NIP-4, you do not need to connect the ports **NIP TX1** and **NIP RX1**.



## ALARMS Connector Pinouts

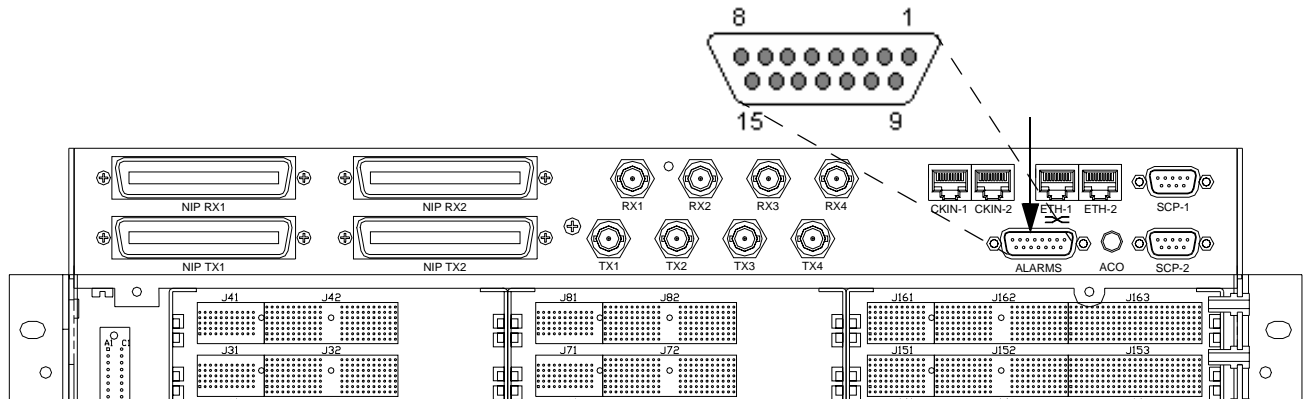

The **ALARMS** port is a female, DB15 port. These are the pinouts of the **ALARMS** port.

Pin	Color	Name	Signal
1	white/blue	normally open, NO	alarm generation #1
2	white/orange	common, C	
3	white/green	normally closed, NC	
4	white/brown	normally open, NO	alarm generation #2
5	white/slate	common, C	
6	red/blue	normally closed, NC	
7	red/orange		N/A
8	red/green		N/A
9	blue/white	ALMSNS2N	alarm sense #2
10	orange/white	ALMSNS2P	
11	green/white	ALMSNS1N	alarm sense #1
12	brown/white	ALMSNS1P	
13	slate/white	ground	
14	blue/red		N/A
15	orange/red	VCC (voltage)	

For the relay contacts on this port, the maximum ratings are 200V DC, or 2 amps, or 30 watts.

## **NHP160 Connector Pinouts**

There are several cables you can use to connect the NHP160 cards. These are the pinouts for the un-terminated SCSI cable (at any length).

<b>SCSI Pin</b>	<b>Color</b>	<b>Signal</b>
1	white/blue	T1E1_RxTIP15
2	white/orange	T1E1_TxTIP15
3	white/green	T1E1_TxTIP14
4	white/brown	T1E1_RxTIP14
5	white/gray	T1E1_RxTIP13
6	red/blue	T1E1_TxTIP13
7	red/orange	T1E1_TxTIP12
8	red/green	T1E1_RxTIP12
9	red/brown	T1E1_TxTIP7
10	red/gray	T1E1_RxTIP7
11	black/blue	T1E1_TxTIP11
12	black/orange	T1E1_RxTIP11
13	black/green	T1E1_TxTIP10
14	black/brown	T1E1_RxTIP10
15	black/gray	T1E1_TxTIP6
16	yellow/blue	T1E1_RxTIP6
17	yellow/orange	NO CONNECT
18	yellow/green	T1E1_TxTIP5
19	yellow/brown	T1E1_RxTIP5
20	yellow/gray	T1E1_TxTIP4
21	purple/blue	T1E1_RxTIP4
22	purple/orange	T1E1_TxTIP9
23	purple/green	T1E1_RxTIP9
24	purple/brown	T1E1_RxTIP8
25	purple/gray	T1E1_TxTIP8
26	white/blue band	T1E1_TxTIP1
27	white/orange band	T1E1_RxTIP1

SCSI Pin	Color	Signal
28	white/green band	T1E1_RxTIP0
29	white/brown band	T1E1_TxTIP0
30	white/gray band	T1E1_TxTIP3
31	red/blue band	T1E1_RxTIP3
32	red/orange band	T1E1_RxTIP2
33	red/green band	T1E1_TxTIP2
34	red/brown band	NO CONNECT
35	blue/white	T1E1_RxRNG15
36	orange/white	T1E1_TxRNG15
37	green/white	T1E1_TxRNG14
38	brown/white	T1E1_RxRNG14
39	gray/white	T1E1_RxRNG13
40	blue/red	T1E1_TxRNG13
41	orange/red	T1E1_TxRNG12
42	green/red	T1E1_RxRNG12
43	brown/red	T1E1_TxRNG7
44	gray/red	T1E1_RxRNG7
45	blue/black	T1E1_TxRNG11
46	orange/black	T1E1_RxRNG11
47	green/black	T1E1_TxRNG10
48	brown/black	T1E1_RxRNG10
49	gray/black	T1E1_TxRNG6
50	blue/yellow	T1E1_RxRNG6
51	orange/yellow	NO CONNECT
52	green/yellow	T1E1_TxRNG5
53	brown/yellow	T1E1_RxRNG5
54	gray/yellow	T1E1_TxRNG4
55	blue/purple	T1E1_RxRNG4
56	orange/purple	T1E1_TxRNG9
57	green/purple	T1E1_RxRNG9
58	brown/purple	T1E1_RxRNG8

## ***Ports and Cables***

### ***NHP160 Connector Pinouts***

---

<b>SCSI Pin</b>	<b>Color</b>	<b>Signal</b>
59	gray/purple	T1E1_TxRNG8
60	blue/white band	T1E1_TxRNG1
61	orange/white band	T1E1_RxRNG1
62	green/white band	T1E1_RxRNG0
63	brown/white band	T1E1_TxRNG0
64	gray/white band	T1E1_TxRNG3
65	blue/red band	T1E1_RxRNG3
66	orange/red band	T1E1_RxRNG2
67	green/red band	T1E1_TxRNG2
68	brown/red band	NO CONNECT

# INDEX

## A

- Accounts
  - GUI ..... 3-14
  - TL1 ..... 3-16
- Alarm reporting ..... 2-13
- Alarm sense ..... 2-12
- Alarms
  - cabling ..... 2-11
- ALARMS port ..... 2-11, A-7
- Assigning an IP address ..... 3-3
- Attaching the front panel ..... 2-28

## B

- BCP155 cards
  - inserting ..... 2-24
- BROADway
  - IP address ..... 3-3

## C

- Cable definitions ..... A-1
- Cabling ..... 2-24
  - alarms ..... 2-11
  - BCP155 cards ..... 2-24
  - E1 ..... 2-17
  - Ethernet port ..... 2-9
  - ground ..... 2-6
  - hardware ..... 2-1
  - network synchronization clock port ... 2-10
  - NHP160 cards ..... 2-19
  - OSP155 cards ..... 2-24
  - power ..... 2-6
  - serial craft port ..... 2-9
  - T1 ..... 2-17
- Cards
  - installing ..... 2-30
  - replacing ..... 2-31
- Changing your password
  - GUI ..... 3-18
  - TL1 ..... 3-18
- Chassis
  - mounting ..... 2-4
  - powering ..... 2-29
- CKIN-1 ..... 2-10, A-4
- CKIN-2 ..... 2-10, A-4

## CLI

- logging in ..... 3-13
  - managing databases ..... 3-25
  - upgrading software ..... 3-34
- ## Clock
- GUI ..... 3-19
- Clock port. See CKIN-1 and CKIN-2
- ## Configuration
- databases ..... 3-23
  - methods ..... 3-1
- ## Creating users
- GUI ..... 3-14
  - TL1 ..... 3-16

## D

- Databases ..... 3-25
- Deleting users
  - GUI ..... 3-14
  - TL1 ..... 3-17

## E

- E1
  - cabling ..... 2-17
- Editing users
  - GUI ..... 3-14
  - TL1 ..... 3-17
- ETH-1 ..... 2-9, A-3
  - logging in ..... 3-8
- ETH-2 ..... 2-9, A-3
  - logging in ..... 3-8
- Ethernet port settings ..... 3-8
- Ethernet port. See ETH-1 and ETH-2

## F

- Fan filter ..... 2-32
- Front panel ..... 2-28

## G

- Grounding ..... 2-6
- GUI ..... 3-9
  - logging in ..... 3-9

## H

- Hardware ..... 2-1
  - overview ..... 2-2

# Index

## I

## I

- Inserting
  - BCP155 cards ..... 2-24
  - NHP160 card ..... 2-19
  - OSP155 cards ..... 2-24
- Installing
  - BCP155 cards ..... 2-24
  - chassis ..... 2-4
  - hardware ..... 2-1
  - new cards ..... 2-30
  - NHP160 cards ..... 2-19
  - OSP155 cards ..... 2-24
  - power ..... 2-6
- Introduction ..... 1-1
- IP address ..... 3-3

## L

- Logging in ..... 3-7, 3-8, 3-9, 3-13

## M

- Managing configuration databases
  - CLI ..... 3-25
  - GUI ..... 3-23
- Manual
  - introduction ..... 1-1
- Memory ..... 3-24
- Mounting
  - center of gravity ..... 2-5
  - chassis ..... 2-4
  - front-mounted ..... 2-5
  - mid-mounted ..... 2-5

## N

- Network synchronization port. See CKIN-1 or CKIN-2
- NHP160 cards
  - cabling ..... 2-19
  - inserting ..... 2-19
- NIP RX1 ..... 2-17, A-5
- NIP RX2 ..... 2-17, A-5
- NIP TX1 ..... 2-17, A-5
- NIP TX2 ..... 2-17, A-5
- NIP400 cards
  - pinouts ..... A-5

## O

- OSP155
  - inserting ..... 2-24
- OSP155 cards
  - BCP155 cards ..... 2-24
- Overview
  - BROADway hardware ..... 2-2

## P

- Passwords
  - GUI ..... 3-18
  - TL1 ..... 3-18
- Pinouts ..... A-1
  - ALARMS ..... A-7
  - CKIN-1 and CKIN-2 ..... A-4
  - ETH-1 and ETH-2 ..... A-3
  - NIP400 ..... A-5
  - SCP-1 and SCP-2 ..... A-2
- Ports ..... A-1
- Powering ..... 2-6
  - chassis ..... 2-29

## R

- Replacing
  - failed cards ..... 2-31
  - fan filter ..... 2-32

## S

- SCP-1 ..... 2-9, A-2
  - logging in ..... 3-7
- SCP-2 ..... 2-9, A-2
- Serial craft port ..... 3-7
  - GUI ..... 3-7
- Setting
  - system clock
    - GUI ..... 3-19
  - system node parameters
    - GUI ..... 3-20
    - TL1 ..... 3-21
  - user accounts
    - GUI ..... 3-14
    - TL1 ..... 3-16
- Software ..... 3-34
- Software configuration methods ..... 3-1
- Software upgrades ..... 3-29
- Stacking ..... 1-2, 3-2, 3-10, 3-20
- System clock
  - GUI ..... 3-19
- System memory ..... 3-24
- System node parameters
  - GUI ..... 3-20
  - TL1 ..... 3-21

## T

- T1
  - cabling ..... 2-17

**U**

Upgrading software

- CLI ..... 3-34
- GUI ..... 3-29

User accounts

- GUI ..... 3-14
- TL1 ..... 3-16

**V**

Viewing users

- GUI ..... 3-14

***Index***

V

---



## Free Manuals Download Website

<http://myh66.com>

<http://usermanuals.us>

<http://www.somanuals.com>

<http://www.4manuals.cc>

<http://www.manual-lib.com>

<http://www.404manual.com>

<http://www.luxmanual.com>

<http://aubethermostatmanual.com>

Golf course search by state

<http://golfingnear.com>

Email search by domain

<http://emailbydomain.com>

Auto manuals search

<http://auto.somanuals.com>

TV manuals search

<http://tv.somanuals.com>