

\$1.00

# OWNER'S GUIDE

ASSEMBLY • OPERATION • MAINTENANCE • PARTS



(Model 280R Shown)

**22" SELF-  
PROPELLED  
ROTARY  
MOWERS**

**Model Numbers**  
**120-280R000**  
**120-282R000**  
*190-086-000*

**Important: Read Safety Rules and Instructions Carefully**

# INDEX

Slope Gauge .....	3
Contents of Hardware Pack .....	4
Rules for Safe Operation .....	5
Assembly .....	6
Controls .....	9
Operation .....	10
Adjustments .....	11
Lubrication .....	11
Maintenance .....	12
Off-Season Storage .....	12
Trouble Shooting Guide .....	14
Repair Parts .....	16-18
Parts Information .....	Back Cover

Dear Customer,

*So often throughout the year we are all in a rush to meet our daily obligations.*

*However, we at MTD Products Inc are taking a quick moment out to say...*

**“Thank you for your business.”**

*Sincerely,*  
MTD PRODUCTS INC



**INSTRUCTIONS GIVEN WITH THIS SYMBOL ARE FOR PERSONAL SAFETY. BE SURE TO FOLLOW THEM.**

**NOTE:** The use of any accessory on this rotary mower other than those manufactured by the mower manufacturer is **not** recommended. GRASS CATCHER Model 086 is available for the mowers shown in this manual.



**WARNING:** To reduce the risk of injury, do not operate mower unless rear trailing shield and guard or entire grass catcher are in their proper places.

**NOTE:** Under normal usage bag material is subject to wear, and should be checked periodically. Be sure any replacement bag complies with the mower manufacturer's recommendations.

**WARNING:** This unit is equipped with an internal combustion engine and should not be used on or near any unimproved forest-covered, brush-covered or grass-covered land unless the engine's exhaust system is equipped with a spark arrester meeting applicable local or state laws (if any). If a spark arrester is used, it should be maintained in effective working order by the operator.

In the State of California the above is required by law (Section 4442 of the California Public Resources Code). Other states may have similar laws. Federal laws apply on federal lands. A spark arrester for the muffler is available through your nearest engine authorized service dealer.

# SLOPE GAUGE

(Keep this sheet in a safe place for future reference.)

Cut Along  Is Line  
**USE THIS SHEET AS A GUIDE TO DETERMINE SLOPES WHERE YOU MAY NOT OPERATE SAFELY.**

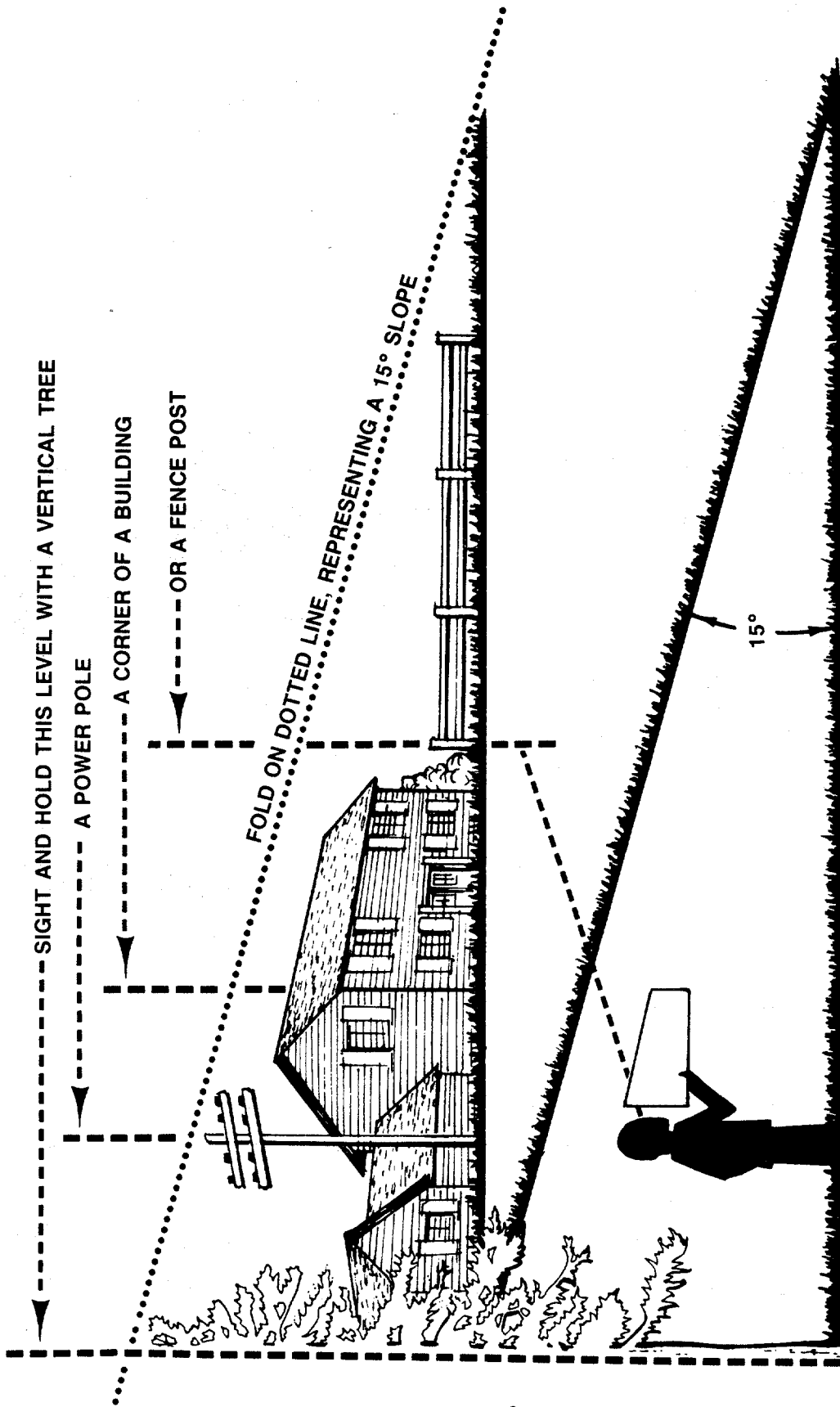

Do not mow on inclines with a slope in excess of 15 degrees (a rise of approximately 2½ feet every 10 feet). A riding mower could overturn and cause serious injury. If operating a walk-behind mower on such a slope, it is extremely difficult to maintain your footing and you could slip, resulting in serious injury.

Operate **RIDING** mowers up and down slopes, never across the face of slopes.

Operate **WALK-BEHIND** mowers across the face of slopes, never up and down slopes.

# CONTENTS OF HARDWARE PACK/PARTS IDENTIFICATION

Remove this sheet from your owner's manual and lay the hardware on the illustration for identification purposes. After assembly, keep the Slope Gauge which is on the reverse side of this sheet for future use.  
 (Hardware pack may contain extra items which are not used on your unit.)

**A ATTACHING THE LOWER HANDLE**

Hairpin Clips

**B ATTACHING THE UPPER HANDLE**

Rope Guide Bolt

Curved Head Bolt

Split Washers 5/16" I.D.

Hex Nuts 5/16-18 Thread

Blade Control Handle

Drive Clutch Control Handle

Throttle Control

Upper Handle

Lower Handle

Starter Rope

Engine

Spark Plug

Rope Guide Bolt

Handle Mounting Bracket

**PARTS IDENTIFICATION**

**C ATTACHING THE THROTTLE CONTROL**

Cable Bracket

Spring Washer 1/4" I.D.

Hex Bolt 1/4-20 x 1 3/4" Long

Hex Nut 1/4-20 Thread

**D SECURING THE CABLES**

Cable Ties



Cut Along this Line

# IMPORTANT

## RULES FOR SAFE OPERATION



THIS SYMBOL POINTS OUT IMPORTANT SAFETY INSTRUCTIONS WHICH, IF NOT FOLLOWED, COULD ENDANGER THE PERSONAL SAFETY AND/OR PROPERTY OF YOURSELF AND OTHERS. READ AND FOLLOW ALL INSTRUCTIONS IN THIS MANUAL BEFORE ATTEMPTING TO OPERATE YOUR LAWN MOWER. FAILURE TO COMPLY WITH THESE INSTRUCTIONS MAY RESULT IN PERSONAL INJURY. WHEN YOU SEE THIS SYMBOL—



**HEED ITS WARNING.**



**DANGER**

Your lawn mower was built to be operated according to the rules for safe operation in this manual. As with any type of power equipment, carelessness or error on the part of the operator can result in serious injury. If you violate any of these rules, you may cause serious injury to yourself or others.



### TRAINING

1. Read this owner's manual carefully in its entirety before attempting to assemble or operate this machine. Be completely familiar with the controls and the proper use of this machine before operating it. Keep this manual in a safe place for future and regular reference and for ordering replacement parts.
2. Your rotary mower is a precision piece of power equipment, not a plaything. Therefore, exercise extreme caution at all times.
3. Never allow children to operate a power mower. Only persons well acquainted with these rules of safe operation should be allowed to use your mower.
4. Keep the area of operation clear of all persons, particularly small children and pets. Stop engine when they are in the vicinity of your mower to help prevent blade contact or thrown object injury. Although the area of operation should be completely cleared of foreign objects, an object may have been overlooked and could be accidentally thrown by the mower in any direction and cause serious personal injury to the operator or any others allowed in the area.



### PREPARATION

1. Thoroughly inspect the area where the equipment is to be used. Remove all stones, sticks, wire, bones and other foreign objects which could be picked up and thrown by the mower in any direction and cause serious personal injury to the operator or any others allowed in the area.
2. Always wear safety glasses or eye shields during operation or while performing an adjustment or repair, to protect eyes from foreign objects that may be thrown from the machine in any direction.
3. Wear sturdy, rough-soled work shoes and close-fitting slacks and shirts to avoid entanglement in the moving parts. Never operate a unit in bare feet, sandals, or sneakers.
4. Check the fuel before starting the engine. Gasoline is an extremely flammable fuel. Do not fill the gasoline tank indoors, while the engine is running, or until engine has been allowed to cool for two minutes after running. Replace gasoline cap securely and wipe off any spilled gasoline before starting the engine as it may cause a fire or explosion.
5. Disengage the self-propelled mechanism or drive clutch on units so equipped before starting the engine.
6. The blade control handle is a safety device. Never attempt to bypass its operation. Doing so makes the safety device inoperative and may result in personal injury through contact with the rotating blade. The blade control handle must operate easily in both directions.
7. Never attempt to make a wheel or cutting height adjustment while the engine is running.
8. Never operate the equipment in wet grass. Always be sure of your footing. A slip and fall can cause serious personal injury. Keep a firm hold on the handle and walk, never run. Mow only in daylight or in good artificial light.

9. For your safety, use the slope gauge included as part of this manual to measure slopes before operating this unit on a sloped or hilly area. If the slope is greater than 15° as shown on the slope gauge, do not operate this unit on that area or serious injury could result.



### OPERATION

1. Do not change the engine governor settings or overspeed the engine. Excessive engine speeds are dangerous.
2. Do not put hands or feet near or under rotating parts. Keep clear of the discharge opening at all times as the rotating blade can cause injury.
3. Stop the blade when crossing gravel drives, walks or roads.
4. After striking a foreign object, stop the engine, remove the wire from the spark plug, and thoroughly inspect the mower for any damage. Repair the damage before restarting and operating the mower.
5. If the equipment should start to vibrate abnormally, stop the engine and check immediately for the cause. Vibration is generally a warning of trouble.
6. Shut the engine off and wait until the blade comes to a complete stop before removing the grass catcher or unclogging the chute. The cutting blade continues to rotate for a few seconds after the engine is shut off. Never place any part of the body in the blade area until you are sure the blade has stopped rotating.
7. Before cleaning, repairing or inspecting, make certain the blade and all moving parts have stopped. Disconnect the spark plug wire, and keep the wire away from the spark plug to prevent accidental starting.
8. Do not run the engine indoors.
9. Mow across the face of slopes, never up-and-down. Exercise extreme caution when changing direction on slopes. Do not mow excessively steep slopes. Always be sure of your footing. A slip and fall can cause serious personal injury.
10. Never operate mower without proper guards, plates or other safety protective devices in place.



### MAINTENANCE AND STORAGE

1. Check the blade and engine mounting bolts at frequent intervals for proper tightness.
2. Keep all nuts, bolts, and screws tight to be sure the equipment is in safe working condition.
3. Never store the equipment with gasoline in the tank inside of a building where fumes may reach an open flame or spark. Allow the engine to cool before storing in any enclosure.
4. To reduce fire hazard, keep the engine free of grass, leaves, or excessive grease.
5. Check the grass catcher bag frequently for wear or deterioration. For safety protection, replace only with new bag meeting original equipment specifications.

# ASSEMBLY INSTRUCTIONS

**IMPORTANT:** This unit is shipped **WITHOUT GASOLINE or OIL**. After assembly, service engine with gasoline and oil as instructed in the separate engine manual packed with your unit.

**NOTE:** Reference to right or left hand side of the mower is observed from the operating position. Refer to parts identification on page 4 for location of parts when assembling the mower.

## Tools Required for Assembly

(1) Pair of Pliers

(1) 1/2" Wrench\*

(2) 7/16" Wrenches\*

\*Or two 6" Adjustable Wrenches

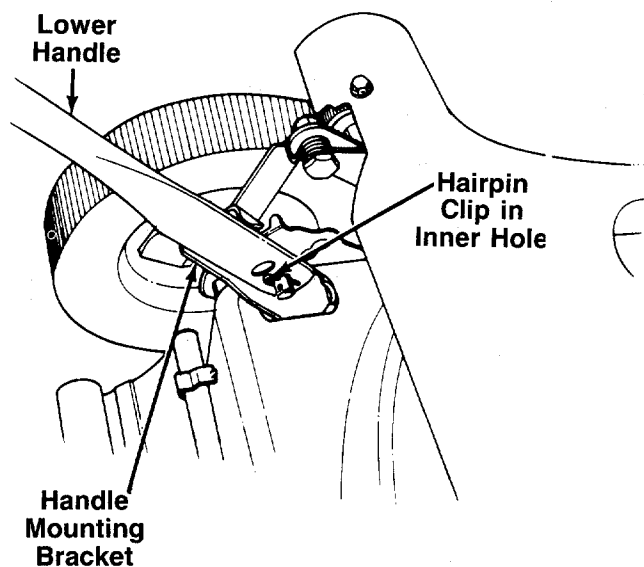

FIGURE 1.

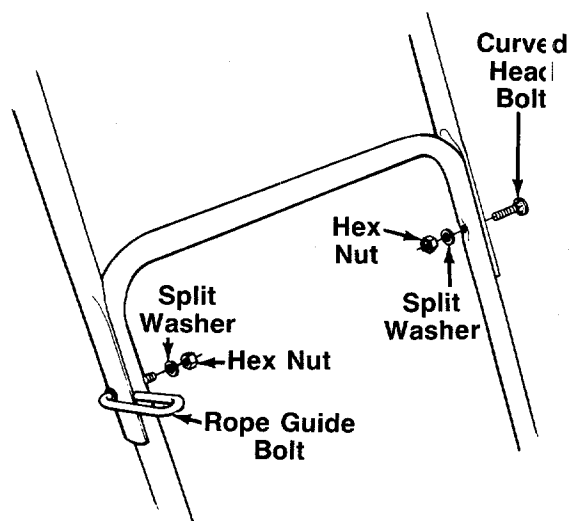

FIGURE 2.

## UNPACKING

1. Remove the lawn mower from the carton by opening the top flaps and lifting the unit out. Be careful of the staples. Make certain all parts and literature have been removed from the carton before the carton is discarded.
2. Disconnect and ground the spark plug wire against the engine. Check beneath the deck for any cardboard packaging. Remove if present.
3. Stretch out all control cables and place on the floor. Be careful not to bend or kink the cables at any time during assembly.
4. Remove page four from this manual and lay the contents of the hardware pack on the illustration for identification.

## ATTACHING THE LOWER HANDLE (Hardware A)

1. Attach the lower handle by placing the bottom holes in the lower handle over the weld pins on the handle mounting brackets extending through the rear of the deck.
2. Using a pair of pliers, squeeze one leg of the lower handle against the handle mounting bracket. Insert the hairpin clip into the **inner** hole on the weld pin. See figure 1. Repeat on other side.

## ATTACHING THE UPPER HANDLE (Hardware B)

1. Place the upper handle in position over the lower handle. The blade control handle (attached to the upper handle) must be facing up.

**NOTE:** The right hand side of the handle will be secured with the rope guide bolt. However, left handed operators may assemble the rope guide bolt to the left side of the handle for easier starting by following steps 2 and 3 and reversing the left and right hand instructions.

2. Secure the left hand side of upper handle using the curved head bolt, split washer and hex nut as shown in figure 2.
3. Insert the rope guide bolt through the right hand side of upper and lower handle from the outside in. Secure with split washer and hex nut, finger tight only at this time.

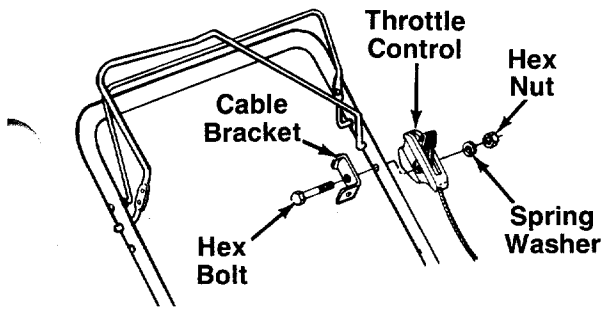

FIGURE 3.

### ATTACHING THE THROTTLE CONTROL (Hardware C)

The throttle control is attached to the engine. Attach the throttle control to the **left** side of upper handle as follows. See figure 3.

1. Route the throttle control cable above the drive cover, and to the inside and below the lower handle.
2. Place cable bracket against left side of upper handle, lining up the hole in the bracket with the bottom hole in upper handle. Place 1/4" hex bolt through cable bracket and handle, from the inside to the outside.
3. Place throttle control on the hex bolt (outside of the upper handle), with the throttle lever facing upward. Secure with spring washer (cupped side against the throttle control) and hex nut.

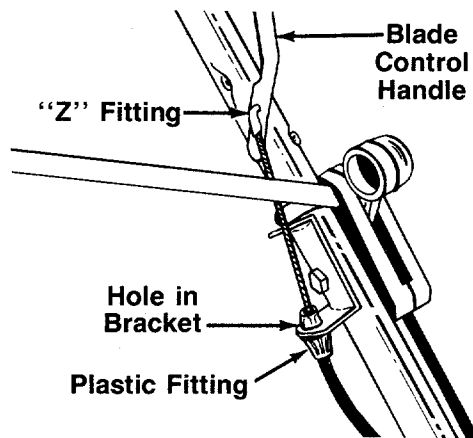

FIGURE 4.

### ATTACHING THE BRAKE CABLE

1. The brake cable is attached to the engine, and has a "Z" fitting on the loose end. Route the brake cable above the drive cover, and to the inside and below the lower handle. Place end of cable through the hole in the bracket as shown in figure 4. Be careful not to bend or kink the cable at any time. Push the plastic fitting until it locks into the hole in the bracket.



**WARNING: Brake cable must be assembled as shown for proper blade brake operation.**

2. Hook the "Z" end of the brake cable into the hole in the blade control handle from the inside to the outside as shown in figure 4.

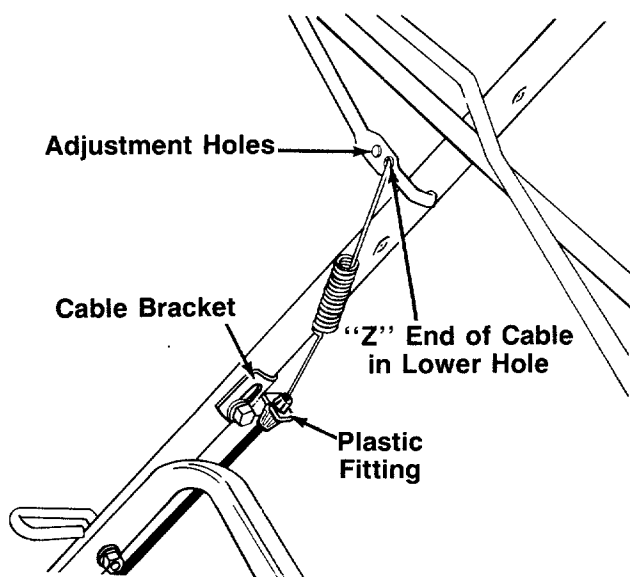

FIGURE 5.

### ATTACHING THE DRIVE CLUTCH CONTROL CABLE

1. The drive clutch cable is attached to the drive cover, and has a spring on one end. Hook the spring on the end of the cable into the lower hole on the drive clutch handle. See figure 5.
2. Pull down on the plastic cable casing, and slip the control wire through the slot in the cable bracket. Push the plastic fitting on the end of the cable casing into the cable bracket.

**NOTE:** If necessary, push down on the drive cover (see figure 6) to obtain sufficient slack in the cable.

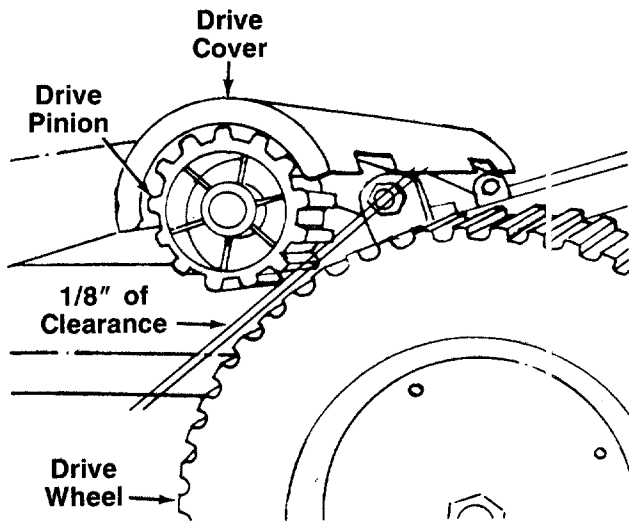

FIGURE 6.

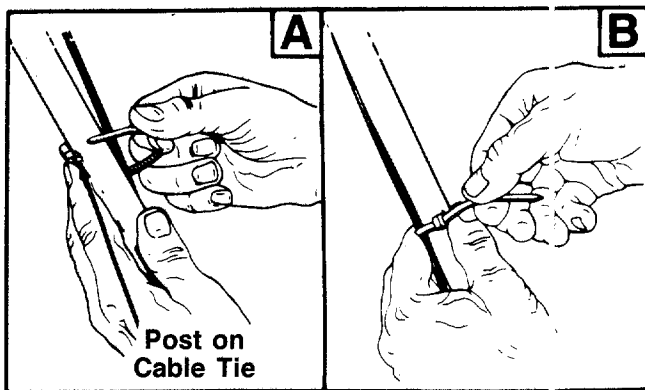

FIGURE 7.

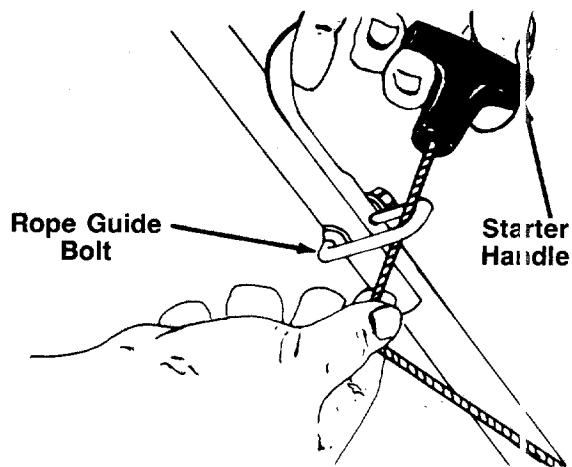

FIGURE 8.

To adjust the drive clutch control cable, proceed as follows.

1. Place the wheels in the lowest cutting height position.
2. Loosen the screw which secures the cable bracket.
3. With the drive clutch control handle released, pull down on the cable and cable bracket until there is a minimum of 1/8" clearance between the drive pinions and the drive wheels. See figures 5 and 6.
4. Tighten the cable bracket in this position.

**NOTE:** Two pieces of cardboard removed from the carton may be used to measure the clearance as follows. Place a piece of cardboard between the drive pinion and wheel on each side of the unit. With the drive clutch control handle released, pull down on the cable and cable bracket until the drive pinions contact the cardboard. Tighten the cable bracket in this position. Remove the cardboard.

**Before starting the mower, check the drive clutch adjustment as follows.**

When the clutch control is engaged (clutch control handle is squeezed against the upper handle), the drive pinions should mesh with the gear tread tires. The drive pinions should clear the drive wheels when the clutch is disengaged by a minimum of 1/8". See figure 6.

If adjustment is necessary, loosen the cable bracket on the upper handle and adjust it as instructed above. If additional adjustment is still required, unhook the cable from the clutch handle, and move it to the hole to obtain less clearance.

#### SECURING THE CABLES (Hardware D)

Secure control cables to the handles as follows.

1. Insert posts on cable ties into holes provided on the handles. The holes may be either on the inside or outside of the handles. Two go on each leg of the lower handle (one near the top and one near the bottom), and one goes on the left side of upper handle. See figure 7A.
2. Secure the cables with the cable ties. See figure 7B.
3. Trim excess ends of cable ties.

#### ATTACHING THE STARTER ROPE

1. The starter rope is inside the top of the engine. Additional rope may be wound around the starter handle. If so, unwind the rope from the handle.
2. With the spark plug wire disconnected and grounded, depress the blade control handle and pull the rope out of the engine.
3. Slip the starter rope into the rope guide bolt as shown in figure 8.
4. Tighten the hex nut on the rope guide bolt securely.



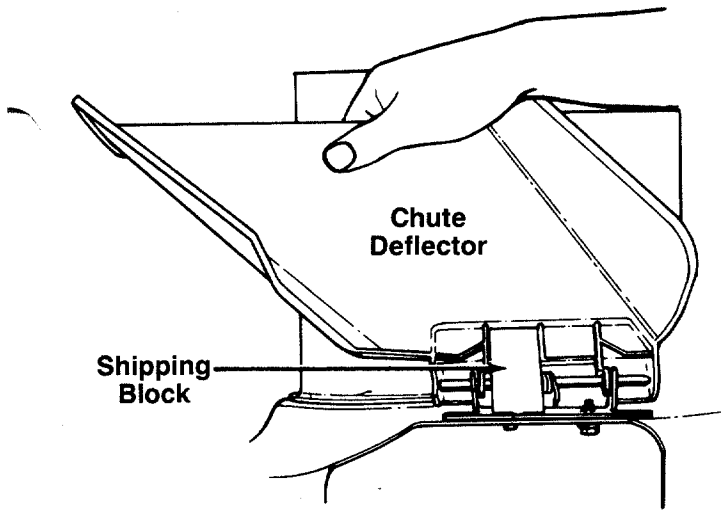

FIGURE 9.

### FINAL ASSEMBLY OF MOWER

1. The chute deflector on your mower is held in an upright position by a block for shipping purposes only. This shipping block must be removed and discarded before the mower is put into operation. See figure 9.

To remove the shipping block, pull the spring-loaded chute toward the engine. Remove the block and carefully lower the chute into operating position, keeping fingers out of the way.

2. Make certain all nuts and bolts are tightened securely.

## CONTROLS

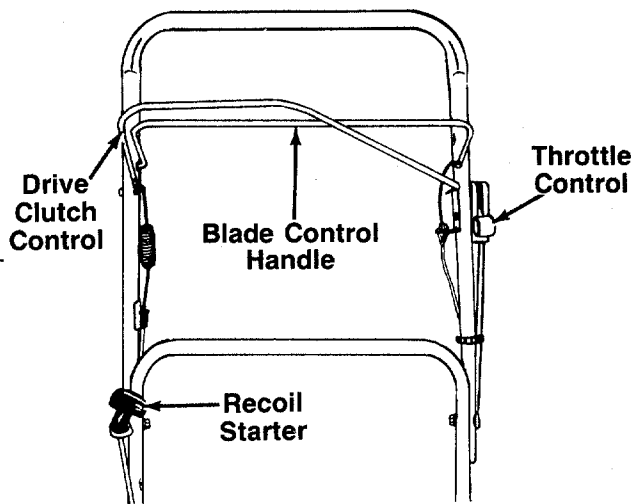

FIGURE 10.

### BLADE CONTROL HANDLE

**WARNING**  
THIS CONTROL MECHANISM IS A SAFETY DEVICE NEVER ATTEMPT TO BYPASS ITS OPERATIONS

The blade control handle is located on the upper handle of the mower. See figure 10. The blade control handle must be depressed in order to operate the unit. Release the blade control handle to stop the engine and blade.



**WARNING: The blade will be rotating whenever the engine is running.**

### THROTTLE CONTROL

The throttle control is located on the side of the upper handle. It is used to regulate the engine speed.



**WARNING: The throttle control cannot be used to stop the engine.**

### RECOIL STARTER

The recoil starter handle is attached to the handle. See figure 10. Stand behind the unit in the operating position to start the unit.

### DRIVE CLUTCH CONTROL

Squeezing the drive clutch control handle engages the drive mechanism to the wheels. Releasing the clutch control stops the wheels from driving. Release the drive clutch control to slow down when negotiating an obstacle, making a turn or stopping. See figure 10.

# OPERATION



FIGURE 11.

Keep hands and feet away from the chute area on cutting deck. See figure 11.

The operation of any lawn mower can result in foreign objects being thrown into the eyes, which can result in severe eye damage. Always wear safety glasses or eye shields. We recommend wide vision safety mask for over spectacles or standard safety glasses.



**NOTE:** Adjust the cutting height of your mower before operating. See adjustment section of this manual.

## BEFORE STARTING

1. Service the engine with gasoline and oil as instructed in the separate engine manual packed with your unit. **Read instructions carefully.**



**WARNING:** Never fill fuel tank indoors, with engine running or until the engine has been allowed to cool for at least two minutes after running.

2. Attach spark plug wire to spark plug.
3. Before each use, check drive clutch adjustment. When the clutch handle is engaged, the drive pinions should mesh simultaneously with the gear tread tires. When the clutch handle is released, the pinions should clear the wheels by a minimum of 1/8". See drive clutch adjustment on page 11 for further details.

## TO START ENGINE AND ENGAGE BLADE



**WARNING:** When starting the unit for the first time, face the mower against a solid object such as a wall, fence, etc. Start the unit, and if it shows any signs of motion with the drive clutch control disengaged, shut the engine off immediately. Refer to page 11 for further instructions on the drive clutch adjustment.

1. Move throttle control lever all the way forward.
2. Standing behind the unit, depress the blade control handle and hold it against the upper handle. Be certain drive clutch handle is released.
3. Grasp the recoil starter handle and pull back rapidly, extending rope fully. Return it slowly to the rope guide bolt.
4. After engine starts, move throttle control to desired engine speed.

**NOTE:** If any problems are encountered, refer to the *Trouble Shooting Guide* on page 17.

## TO STOP ENGINE AND BLADE

1. Release the blade control handle to stop the engine and blade.



**WARNING:** The blade continues to rotate for a few seconds after the engine is shut off.

2. Disconnect the spark plug wire and ground it against the engine to prevent accidental starting while equipment is unattended.

## USING YOUR ROTARY MOWER

Be sure that lawn is clear of stones, sticks, wire, or other objects which could damage lawn mower or engine. Such objects could be accidentally thrown by the mower in any direction and cause serious personal injury to the operator and others.

For the best results, do not cut wet grass because it tends to stick to the underside of the mower, preventing proper discharge of grass clippings, and could cause you to slip and fall. New grass, thick grass or wet grass may require a narrower cut. Blade speed should be adjusted to the condition of the lawn.

The best mowing pattern is one that allows the clippings to discharge towards the uncut part of the lawn. This permits recutting of the clippings to further pulverize them. When cutting high weeds, discharge towards cut portion, then recut at right angles to first direction.

For best results, cut off one-third or less of the total length of the grass. Lawn should be cut in the fall as long as there is growth.

This mower is designed to be operated at full throttle to give you the best cut and do the most effective job of bagging the cut grass.



**WARNING:** If you strike a foreign object, stop the engine. Remove wire from spark plug, thoroughly inspect the mower for any damage, and repair the damage before restarting and operating the mower. Extensive vibration of the mower during operation is an indication of damage. The unit should be promptly inspected and repaired.

## ADJUSTMENTS



**WARNING:** Do not at any time make any adjustment to lawn mower without first stopping engine and disconnecting spark plug wire.

### CUTTING HEIGHT ADJUSTMENT

An adjusting plate and thumb lever at each wheel position provides cutting height adjustment. Each adjusting plate has nine height positions. Height of cut will be changed when the thumb lever is moved from one hole to another. Simply depress the lever towards wheel and move wheel and lever assembly to desired position. All wheels must be placed in the same relative position. See figure 12.

For rough or uneven lawns, move the wheels to a position which will give a higher cutting height.

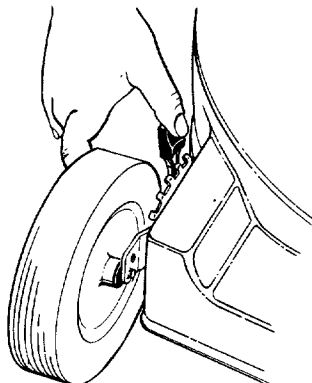

FIGURE 12.

### DRIVE CLUTCH ADJUSTMENT

The drive pinions should be a minimum of 1/8" from the drive wheels when the clutch is disengaged (clutch control handle is not squeezed against upper handle). Refer to figure 6. When the clutch control is engaged, the drive pinions should mesh with the tires.

If adjustment is necessary, loosen the screw which secures the cable bracket on the handle. Adjust until there is at least 1/8" of clearance. If additional adjustment is required, unhook the cable from the clutch handle, and move it to the higher hole to obtain less clearance. Using the lower hole gives more clearance. Retighten the cable bracket when the correct adjustment is reached.

### THROTTLE CONTROL ADJUSTMENT

If the throttle control needs adjustment or has been replaced, adjust the throttle control as follows.

1. Loosen (do not remove) the screw on the cable clamp so that the cable will move freely under the clamp. See figure 13.
2. Place the throttle control lever on the handle all the way forward to START position.
3. Place the control lever on the engine in the full open position by pushing it as far toward the **outside** of the engine as it will go. Tighten the screw on the cable clamp to secure the cable in this position.

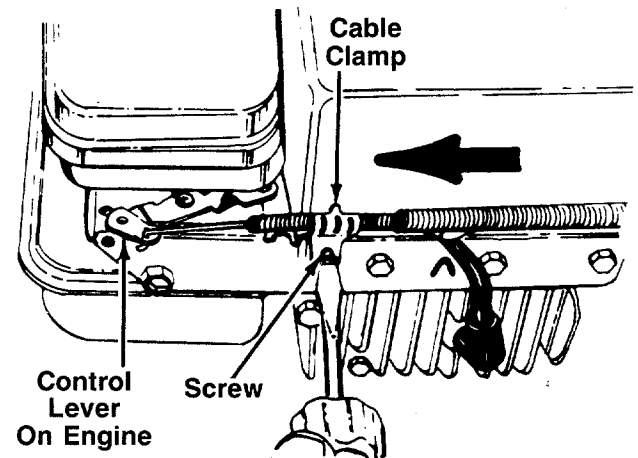

FIGURE 13.

### CARBURETOR ADJUSTMENTS



**WARNING:** If any adjustments are made to the engine while the engine is running (e.g. carburetor), keep clear of all moving parts. Be careful of heated surfaces and muffler.

Minor carburetor adjustments may be required to compensate for differences in fuel, temperature, altitude and load. To adjust carburetor, refer to the separate engine manual packed with your mower.

**NOTE:** A dirty air cleaner will cause an engine to run rough. Be certain air cleaner is clean and attached to the carburetor before adjusting carburetor. Refer to the separate engine manual.

---

## LUBRICATION

---



**WARNING:** Always stop engine and disconnect spark plug wire before cleaning, lubricating or doing any kind of work on lawn mower.

**Blade Control**—Lubricate the pivot points on the blade control handle and the brake cable at least once a season with light oil. The blade control must operate freely in both directions.

**Chute Deflector**—The torsion spring and pivot point should be lubricated periodically with light oil to prevent any rust or binding. Deflector must work freely.

**Wheels**—The mower may be provided with ball bearing wheels. Lubricate at least once a season with light oil. Also, if the wheels are removed for any reason, lubricate the surface of the axle bolt and the inner surface of the wheel with light oil. A 4 oz. plastic bottle of light oil lubricant is available. Order part number 737-0170. Engine oil may also be used.

**Engine**—Follow engine manual for lubrication instructions.

**Throttle**—Periodically lubricate throttle control lever and throttle wire assembly with a few drops of light oil for ease of operation.

**Chain**—The chain should be lubricated periodically with a few drops of light oil to prevent any rust or binding. Use very little or no oil if unit is being used in a dusty or sandy area.

---

## MAINTENANCE

---



**WARNING:** Be sure to disconnect and ground the spark plug wire before performing any repairs or maintenance.

**NOTE:** When tipping the unit, empty the fuel tank and keep engine spark plug side up.

### TROUBLE SHOOTING

Refer to page 17 of this manual for trouble shooting information.

### CUTTING BLADE

When removing the cutting blade for sharpening or replacement, protect hands by using heavy gloves or a rag to grasp the cutting blade. Remove the bolt and bell washer which hold the blade and adapter to the engine crankshaft. Remove the blade and adapter from the crankshaft.

If the blade or blade adapter needs replacing, remove the two small bolts, lock washers and nuts which hold the blade to the adapter.



**WARNING:** Periodically inspect the blade adapter for cracks, especially if you strike a foreign object. Replace when necessary.

When sharpening the blade, follow the original angle of grind as a guide. It is **extremely important** that each cutting edge receives an equal amount of grinding to prevent an unbalanced blade. An unbalanced blade will cause excessive vibration when rotating at high speeds, may cause damage to the mower and could break, causing personal injury.

It is recommended that the blade always be removed from the adapter for the best test of balance.

The blade can be tested by balancing it on a round shaft screwdriver. Remove metal from the heavy side until it balances evenly.

Before reassembling the blade and the blade adapter to the unit, lubricate the engine crankshaft and the inner surface of the blade adapter with light oil. Lubricating the bolt holes, bolts and inner surface of the nuts with light oil is also recommended. A 4 oz. plastic bottle of light oil lubricant is available. Order part number 737-0170. Engine oil may also be used.

When replacing the blade, be sure to install the blade with the side of the blade marked "Bottom" (or with part number) facing the ground when the mower is in the operating position.

### Blade Mounting Torque

Center Bolt and Blade Adapter Bolts:  
375 in. lb. min., 450 in. lb. max.

To insure safe operation of your unit, **all** nuts and bolts must be checked periodically for correct tightness.

### DECK

The underside of the mower deck should be cleaned after each use to prevent a buildup of grass clippings, leaves, dirt or other matter. If this debris is allowed to accumulate, it will invite rust and corrosion, and may cause an uneven discharge of grass clippings at the next cutting.

The deck may be cleaned by tilting the mower and scraping clean with a suitable tool (make certain the spark plug wire is disconnected).

## ENGINE

Refer to the separate engine manual for engine maintenance instructions.

Maintain **engine oil** as instructed in the separate engine manual packed with your unit. Read and follow instructions carefully.

Service **air cleaner** every 25 hours under normal conditions. Clean every few hours under extremely dusty conditions. Poor engine performance and flooding usually indicates that the air cleaner should be serviced. To service the air cleaner, refer to the separate engine manual packed with your unit.

The **spark plug** should be cleaned and the gap reset once a season. Spark plug replacement is recommended at the start of each mowing season; check engine manual for correct plug type and gap specifications.

**Clean the engine** regularly with a cloth or brush. Keep the cooling system (blower housing area) clean to permit proper air circulation which is essential to engine performance and life. Be certain to remove all grass, dirt and combustible debris from muffler area.

---

## OFF-SEASON STORAGE

---

The following steps should be taken to prepare lawn mower for storage.

1. Clean and lubricate mower thoroughly as described in the lubrication instructions.
2. Refer to separate engine manual for correct engine storage instructions.
3. Coat mower's cutting blade with chassis grease to prevent rusting.
4. Store mower in a dry, clean area.

**NOTE:** *When storing any type of power equipment in an unventilated or metal storage shed, care should be taken to rust-proof the equipment. Using a light oil or silicone, coat the equipment, especially cables and all moving parts.*

# Models 280R and 282R

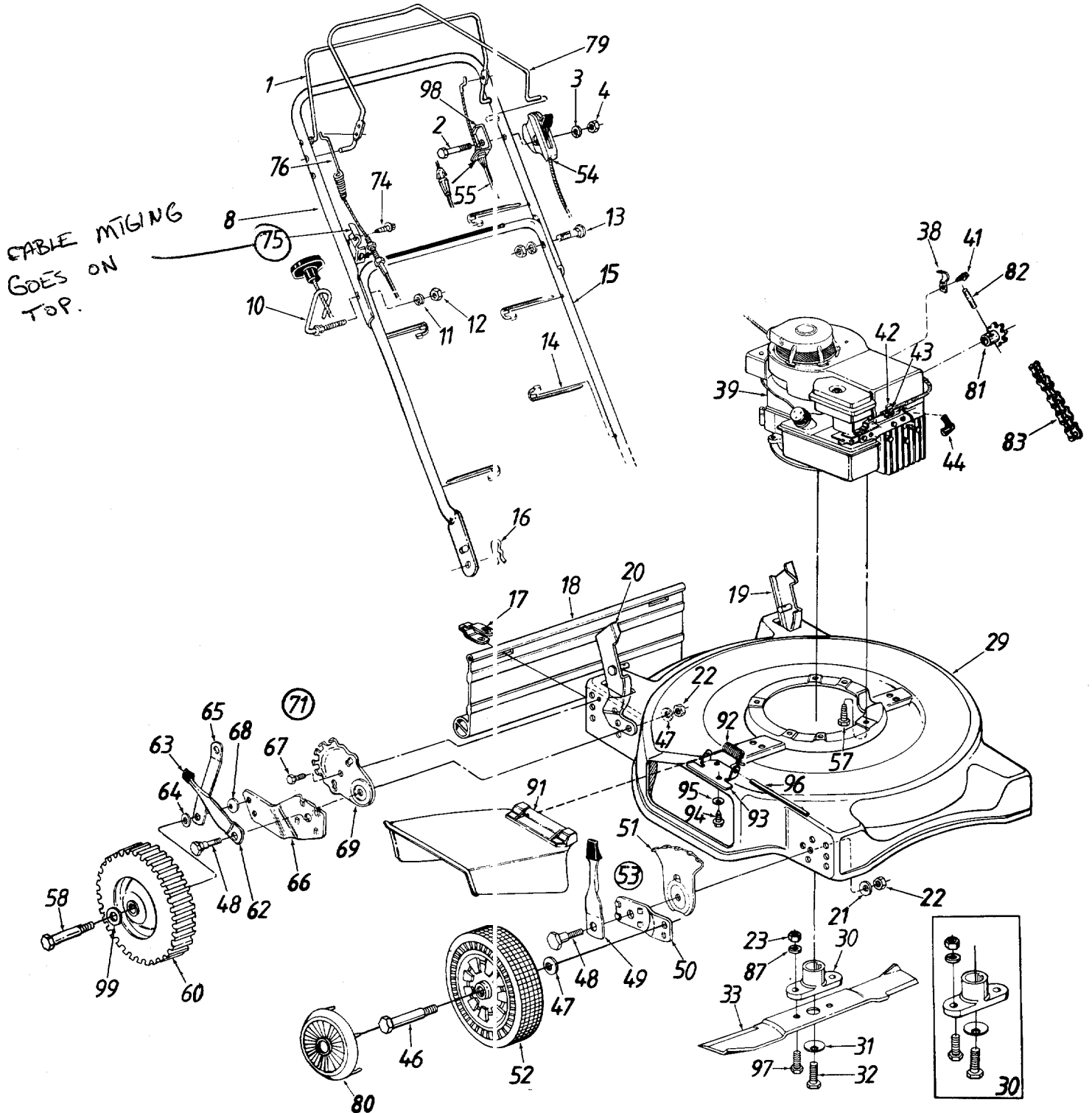

\*For faster service obtain standard nuts, bolts and washers locally. If these items cannot be obtained locally, order by part number and size as shown on parts list.

***Optional Hub Caps	
Red	731-0124A
Orange	731-0254
Black	731-0354
Gray	731-0355A

# Models 280R and 282R

## PARTS LIST FOR MODELS 280R AND 282R ROTARY MOWERS

REF. NO.	PART NO.	CODE	DESCRIPTION	REF. NO.	PART NO.	CODE	DESCRIPTION
1	747-0748	N	Control Handle	54	746-0801	N	Throttle Control Ass'y. Comp.
2	710-0136		Hex Bolt 1/4-20 x 1.75" Lg.				51.62" Lg.
3	736-0175		Spr. Wash. .265" I.D. x .562" O.D.	55	746-0550		Control Cable—39"
4	712-0287		Hex Nut 1/4-20 Thd.*	57	710-0654A		Hex L-Wash. Hd. Scr. 3/8-16 x 1.0" Lg.
8	749-0756		Upper Handle	58	738-0102		Rear Axle Bolt
10	710-0842B		Rope Guide Bolt	60	**		Rear Wheel Ass'y. Comp.
11	736-0119		L-Wash. 5/16" I.D.*	62	732-0417A		Spring Lever
12	712-0267		Hex Nut 5/16-18 Thd.*	63	720-0190		Spring Lever Knob
13	710-0671		Curved Carriage Bolt 5/16-18 x 1.38" Lg.	64	736-0192		Fl-Wash. .531" I.D. x .93"
14	726-0240		Cable Tie	65	14760A		Link 4.58" Lg.
15	749-0372B		Lower Handle	66	14765		Pivot Bar R.H.
16	714-0104		Hairpin Cotter		14766		Pivot Bar L.H. (Not Shown)
17	17098		Hinge Clip	67	710-0892		Hex AB-Tap 1/4-.62" Lg.
18	731-0872		Rear Flap	68	736-0105		Bell-Wash. .380" I.D. x .88"
19	17189		Handle Bracket Ass'y.—L.H.	69	14764C		Index Plate
20	17188		Handle Bracket Ass'y.—R.H.	71	16106		Rear Height Adj. Ass'y.—R.H.
21	736-0356		Bell-Wash. .39" I.D. x 1.38"		16107		Rear Height Adj. Ass'y.—L.H. (Not Shown)
22	712-0798		Hex Nut 3/8-16 Thd.*	74	710-0726		Hex Wash. AB-Tap Scr. 5/16 x .75" Lg.
23	712-0241		Hex Nut 3/8-24 Thd.				Cable Brkt.
29	17046	638	22" Deck Ass'y.	75	16309A		Clutch Cable w/Spring—33"
30	753-0484		Blade Adapter Kit	76	746-0628		S.P. Bail Ass'y.
31	736-0452		Bell-Wash. .39" I.D.	79	747-0749	N	Hub Cap (Optional)
32	710-1044		Hex Bolt 3/8-24 x 1.5" Lg.	80	***		10 Tooth Sprocket Ass'y.
33	742-0522		22" Blade	81	713-0308		Spring Pin Spir. 3/16" Dia. x 1" Lg.
38	12894A		Cable Clamp	82	715-0247		#48 Chain 1/2" Pitch 50 Links (Endless)
39	—		Engine				L-Wash. 3/8" I.D.*
41	710-0429		Hex B-Tap Scr. #10 x .38"	83	713-0311		Chute Deflector Ass'y.
42	751-0369		Cable Clamp				Torsion Spring
43	710-0227		Hex AB-Tap Scr. #8 x 38" Lg.	87	736-0169		Adapter Plate
44	735-0639		Spark Plug Boot (Optional)	91	731-1034		Hex Self-Tap Scr. 1/4-20 x .5" Lg.
46	738-0102		Front Axle Bolt	92	732-0593		Bell-Wash. 1/4" I.D.
47	736-0105		Bell-Wash. .400" I.D. x .88"	93	17032		Hinge Pin
48	738-0507B		Shld. Bolt .50" Dia. x .357"	94	710-0599		Hex Bolt 3/8-24 x 1" Lg.
49	14832		Spring Lever Ass'y. w/Knob	95	736-0270		Cable Mtg. Bracket
50	15262B		Pivot Bar	96	747-0710		Fl-Wash. .531" I.D. x .93"
51	15261A		Height Adj. Plate	97	710-1055		
52	**		Front Wheel Ass'y. Comp.	98	17173	N	
53	14578		Height Adj. Ass'y. Comp.—R.H.	99	736-0192		
	14579		Height Adj. Ass'y. Comp.—L.H. (Not Shown)				

\*\*WHEEL CHART (8 x 1.75)

Wheels w/o Bearings		Wheels With Bearings			
Tread†	Ass'y. Comp.	Tread†	Ass'y. Comp.	Bearings	
Gear	734-1174A	Gear	734-0538 734-1026	Plastic Brg. 1/2" I.D.-741-0262 (2 per Wheel) Ball Brg. 1/2" I.D.-741-0180 (2 per Wheel)	
Bar	734-1608	"T" Tread	734-1566 734-1259	Plastic Brg. 1/2" I.D.-741-0262 (2 per Wheel) Ball Brgs.: 3/8" I.D.-741-0267, 1/2" I.D.-741-0484, Spacer-750-0434 (Uses Front Axle Bolt 710-1020)	
Waffle	734-1162A	Waffle	734-0812 734-0924 734-0645	Plastic Brg. 1/2" I.D.-741-0262 (2 per Wheel) Ball Brg. 1/2" I.D.-741-0180 (2 per Wheel) Ball Brgs.: 3/8" I.D.-741-0267, 1/2" I.D.-741-0484, Spacer-750-0434 (Uses Front Axle Bolt 710-1020)	

†Tread Type: Gear  ; Bar  ; "T" Tread  ; Waffle 

# Models 280R and 282R

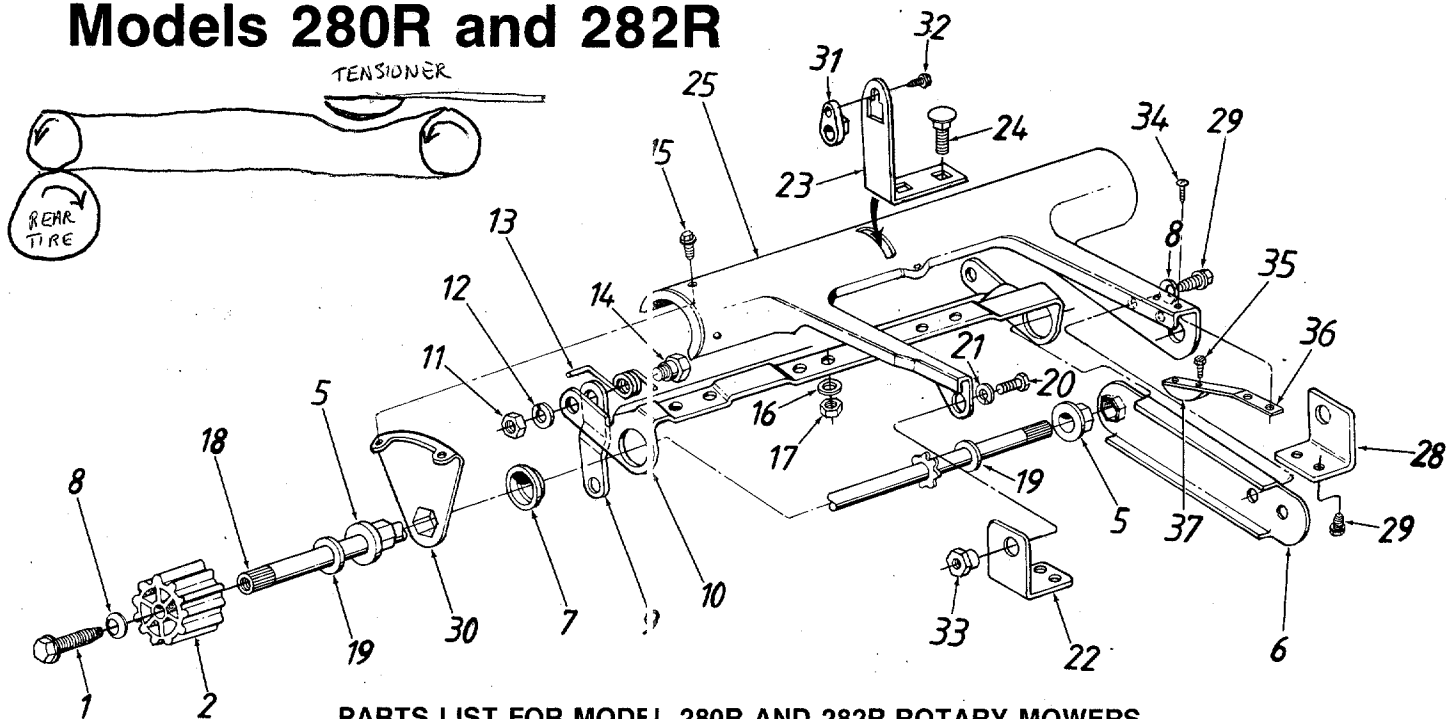

**PARTS LIST FOR MODEL 280R AND 282R ROTARY MOWERS**

REF. NO.	PART NO.	CODE	DESCRIPTION	REF. NO.	PART NO.	CODE	DESCRIPTION
1	710-0642		Hex Wash. Hd. Tap Scr. 1/4-20 x .75" Lg.	20	710-0168		Hex Bolt 3/8-16 x .5" Lg.*
2	731-0908		Wheel Drive Pinion	21	736-0169		L-Wash. 3/8" I.D.
5	741-0503		Hex Flange Brg. .504" I.D.	22	17614		Pivot Bracket—R.H.
6	17018		Hex Bearing Support	23	16756		Engagement Arm—L.H.
7	741-0504		Flange Bearing .879" I.D.	24	710-0258		Hex Bolt 1/4-20 x .62" Lg.
8	736-0270		Bell-Wash. .265" I.D. x .75" O.D.	25	17726	N	Rear Pinion Pivot Cover
9	14760A		Link 4.58" Lg.	28	17613		Pivot Bracket—L.H.
10	16832		Drive Engagement Cam	29	710-0892		Hex Wash. Hd. AB-Tap Scr. 1/4 x .62" Lg.
11	712-0267		Hex Nut 5/16-18 Thd.*	30	17017		Hex Bearing Axle Brkt.
12	736-0119		L-Wash. 5/16" I.D.*	31	746-0606		Barrel Cable Hold-Down—R.H.
13	732-0569		Torsion Spring—R.H.	32	710-0919		Hex B-Tap Scr. #10 x .44" Lg.
	732-0570		Torsion Spring—L.H. (Not Shown)	33	738-0529		Shld. Nut .625" Dia. x .165" Lg.
14	738-0754		Shoulder Bolt .437" Dia.	34	710-0351		Truss Mach. B-Tap Scr. #10 x .5" Lg.
15	710-0892		Hex L-Hd. AB-Tap Scr. 1/4" x .62" Lg.	35	710-0429		Hex B-Tap Scr. #10 x 3/8" Lg.
16	736-0329		L-Wash. 1/4" I.D.*	36	732-0634	N	Cantilever Spring
17	712-0287		Hex Nut 1/4-20 Thd.*	37	731-1136	N	Chain Tensioner
18	738-0732		Drive Shaft Ass'y.				
19	736-0160		FI-Wash. .531" I.D. x .93" O.D.				

## NOTE

This instruction manual covers various models and all specifications shown do not necessarily apply to your model. Specifications subject to change without notice or obligation.

NOTE: The engine is not under warranty by the mower manufacturer. . . If repairs or service is needed on the engine, please contact your nearest authorized engine service outlet. Check the "Yellow Pages" of your telephone book under "Engines—Gasoline."

**Find It Fast  
In The  
Yellow Pages**

**CODE: N** notates a **new part** (not previously existing). A three digit number is the **color code**. Specify color code as shown below if color or finish is important when ordering parts. [i.e., 638 for Red Finish].

### Color Codes

456—Radiant Tangerine	629—Silver Flake
460—Green Flake	630—Metallic Blue
483—Charcoal Gray	637—Black
498—Yellow	638—Red
499—Beige	640—Green
621—Brilliant Fire Mist	646—CM Blue



# Trouble Shooting Guide

Trouble	Possible Cause(s)	Corrective Action
Engine fails to start	<ol style="list-style-type: none"> <li>1. Blade control handle disengaged.</li> <li>2. Spark plug wire disconnected.</li> <li>3. Throttle control lever not in FAST or START position.</li> <li>4. Fuel tank empty, or stale fuel.</li> <li>5. Blocked fuel line.</li> <li>6. Faulty spark plug.</li> <li>7. Engine flooded.</li> </ol>	<ol style="list-style-type: none"> <li>1. Engage blade control handle.</li> <li>2. Connect wire to spark plug.</li> <li>3. Move throttle lever to FAST or START position.</li> <li>4. Fill tank with clean, fresh gasoline.</li> <li>5. Clean fuel line.</li> <li>6. Clean, adjust gap or replace.</li> <li>7. Remove spark plug, dry the plug, and crank engine with plug removed and throttle in off position. Replace spark plug, connect wire and resume starting procedures.</li> </ol>
Engine runs erratic	<ol style="list-style-type: none"> <li>1. Unit running in START position.</li> <li>2. Spark plug wire loose.</li> <li>3. Blocked fuel line or stale fuel.</li> <li>4. Vent in gas cap plugged.</li> <li>5. Water or dirt in fuel system.</li> <li>6. Dirty air cleaner.</li> <li>7. Carburetor out of adjustment.</li> </ol>	<ol style="list-style-type: none"> <li>1. Move throttle lever to FAST position.</li> <li>2. Connect and tighten spark plug wire.</li> <li>3. Clean fuel line; fill tank with clean, fresh gasoline.</li> <li>4. Clear vent.</li> <li>5. Drain fuel tank. Refill with fresh fuel.</li> <li>6. Clean air cleaner.†</li> <li>7. Adjust carburetor.†</li> </ol>
Engine overheats	<ol style="list-style-type: none"> <li>1. Engine oil level low.</li> <li>2. Air flow restricted.</li> <li>3. Carburetor not adjusted properly.</li> </ol>	<ol style="list-style-type: none"> <li>1. Fill crankcase with proper oil.</li> <li>2. Remove blower housing and clean.†</li> <li>3. Adjust carburetor.†</li> </ol>
Occasional skip (hesitates) at high speed	<ol style="list-style-type: none"> <li>1. Carburetor idle speed too slow.</li> <li>2. Spark plug gap too close.</li> <li>3. Carburetor idle mixture adjustment improperly set.</li> </ol>	<ol style="list-style-type: none"> <li>1. Adjust carburetor.†</li> <li>2. Adjust gap to .030".</li> <li>3. Adjust carburetor.†</li> </ol>
Idles poorly	<ol style="list-style-type: none"> <li>1. Spark plug fouled, faulty or gap too wide.</li> <li>2. Carburetor improperly adjusted.</li> <li>3. Dirty air cleaner.</li> </ol>	<ol style="list-style-type: none"> <li>1. Reset gap to .030" or replace spark plug.</li> <li>2. Adjust carburetor.†</li> <li>3. Clean air cleaner.†</li> </ol>
Mower will not drive	<ol style="list-style-type: none"> <li>1. Drive clutch cable out of adjustment.</li> <li>2. Chain out of adjustment or stretched.</li> </ol>	<ol style="list-style-type: none"> <li>1. Adjust drive clutch cable (see adjustment section).</li> <li>2. Adjust or replace chain.</li> </ol>
Excessive vibration	<ol style="list-style-type: none"> <li>1. Cutting blade loose or unbalanced.</li> <li>2. Bent cutting blade.</li> </ol>	<ol style="list-style-type: none"> <li>1. Tighten blade and adapter. Balance blade.</li> <li>2. Replace blade.</li> </ol>
Mower will not discharge grass	<ol style="list-style-type: none"> <li>1. Engine speed too low.</li> <li>2. Wet grass.</li> <li>3. Excessively high grass.</li> </ol>	<ol style="list-style-type: none"> <li>1. Set throttle between 3/4 and full throttle.</li> <li>2. Do not mow when grass is wet; wait until later to cut.</li> <li>3. Mow once at a high cutting height, then mow again at desired height or make a narrower cutting swath (1/2 width).</li> </ol>
Uneven cut	<ol style="list-style-type: none"> <li>1. Wheels not positioned correctly.</li> <li>2. Dull blade.</li> </ol>	<ol style="list-style-type: none"> <li>1. Place all four wheels in same height position.</li> <li>2. Sharpen or replace blade.</li> </ol>

†Refer to separate engine manual packed with your unit.

**Note:** For repairs beyond the minor adjustments listed above, contact your local authorized service dealer.





# PARTS INFORMATION

## POWER EQUIPMENT PARTS AND SERVICE

Parts and service are available through the authorized service firms listed below. All orders should specify the model number of your unit, part numbers, description of parts and the quantity of each part required.

**NOTE:** If any parts are found to be missing or defective upon assembly of this unit, write to advise the factory so that immediate replacement can be made.

<b>ARKANSAS</b>	<b>NORTH LITTLE ROCK</b>
Sutton's Lawn Mower Shop.....	5301 Roundtop Drive Box 368, Rt. 4 ..... 72117
<b>CALIFORNIA</b>	<b>PORTERVILLE</b>
Billious .....	75 North D Street ..... 93257
<b>COLORADO</b>	<b>DENVER</b>
Spitzer Industrial Products Co. . .	6601 N. Washington St. .... 80229
<b>FLORIDA</b>	<b>JACKSONVILLE</b>
Radco Distributors .....	4909 Victor St. Box 5459 ..... 32207
	<b>HIALEAH</b>
Small Eng. Dist. ....	7995 W. 26th Court ..... 33016
<b>ILLINOIS</b>	<b>LYONS</b>
Keen Edge Co. ....	8615 Ogden Ave. .... 60534
<b>INDIANA</b>	<b>ELKHART</b>
Parts & Sales Inc. ....	2101 Industrial Pkwy. Box 277 ..... 46516
<b>IOWA</b>	<b>DUBUQUE</b>
Power Lawn & Garden Equip. ....	2551 J.F. Kennedy ..... 52001
<b>MARYLAND</b>	<b>BELTSVILLE</b>
Center Supply Co. ....	6802 Industrial Dr. #208 ..... 20705
<b>MASSACHUSETTS</b>	<b>SPRINGFIELD</b>
Morton B. Collins Co. ....	300 Birnie Ave. .... 01107
<b>MICHIGAN</b>	<b>MOUNT CLEMENS</b>
Power Equipment Dist. ....	340 Hubbard ..... 48043
<b>MINNESOTA</b>	<b>PLYMOUTH</b>
Hance Distributing Inc. ....	12795 16th Ave. North ..... 55441
<b>MISSOURI</b>	<b>EARTH CITY</b>
Oscar Wilson Engine & Parts ....	4159 Shoreline Dr. .... 33045
	<b>KANSAS CITY</b>
Automotive Equip. Service .....	3117 Holmes St. .... 34109
<b>NEW YORK</b>	<b>CARTHAGE</b>
Gamble Dist., Inc. ....	West End Ave. Box 389 ..... 13619

## BRIGGS AND STRATTON, TECUMSEH AND PEERLESS PARTS AND SERVICE

Briggs & Stratton, Tecumseh and Peerless parts and service should be handled by your nearest authorized engine service firm. Check the yellow pages of your telephone directory under the listing **Engines—Gasoline**, Briggs & Stratton or Tecumseh Lauson.

<b>NORTH CAROLINA</b>	<b>BROWNS SUMMIT</b>
Dixie Sales Company .....	5920 Summit Ave. .... 27214
<b>OHIO</b>	<b>CARROLL</b>
Stebe's Mid-State Mower Supply	Box 366, 71 High St. .... 43112
	<b>CLEVELAND</b>
Bleckrie, Inc. ....	7900 Lorain Ave. .... 44102
	<b>WADSWORTH</b>
National Central .....	687 Seville Rd. .... 44281
	<b>YOUNGSTOWN</b>
Burton Supply Co. ....	1301 Logan Ave. Box 929 ..... 44501
<b>PENNSYLVANIA</b>	<b>HARRISBURG</b>
EECO Inc. ....	4021 N. 6th St. .... 17110
	<b>PITTSBURGH</b>
Bluemont Co. ....	11101 Frankstown Rd. . 15235
	<b>PUNXSUTAWNEY</b>
Frank Roberts & Sons .....	R.D. 2 ..... 15767
	<b>SCRANTON</b>
Scranton Auto Ignition Co. ....	1133-35 Wyoming Ave. . 18509
<b>TENNESSEE</b>	<b>KNOXVILLE</b>
Ace Distributors .....	2103 Magnolia ..... 37917
	<b>NASHVILLE</b>
Chilton Air Cooled Engine .....	319 4th Ave. S. .... 37210
<b>TEXAS</b>	<b>DALLAS</b>
Marr Brothers, Inc. ....	423 E. Jefferson ..... 752
<b>UTAH</b>	<b>SALT LAKE CITY</b>
Powered Products .....	1661 N. Beck St. .... 84116
<b>VIRGINIA</b>	<b>ASHLAND</b>
RBI Corp. ....	101 Cedar Ridge Dr. . 23005
<b>WASHINGTON</b>	<b>SEATTLE</b>
Equip. Northwest .....	1410 14th Ave. .... 98122
<b>WISCONSIN</b>	<b>MILWAUKEE</b>
Wisconsin Magneto Inc. ....	4727 N. Teutonia St. . 53209
<b>PUERTO RICO</b>	<b>RAMEY</b>
Island Distribution Center .....	102 N. St. .... 00604

### WARRANTY PARTS AND SERVICE POLICY

(0689)

The purpose of warranty is to protect the customer from defects in workmanship and materials, defects which are NOT detected at the time of manufacture. It does not provide for the unlimited and unrestricted replacement of parts. Use and maintenance are the responsibility of the customer. The manufacturer cannot assume responsibility for conditions over which it has no control. Simply put, if it's the manufacturer's fault, it's the manufacturer's responsibility; if it's the customer's fault, it's the customer's responsibility.

#### CLAIMS AGAINST THE MANUFACTURER'S WARRANTY INCLUDES:

1. Replacement of Missing Parts on new equipment.
2. Replacement of Defective Parts within the warranty period.
3. Repair of Defects within the warranty period.

All claims MUST be substantiated with the following information:

1. Model Number, Serial Number and/or Date Code of unit involved.
2. Date unit was purchased.
3. Date of Failure.
4. Nature of Failure.

MTD PRODUCTS INC • P.O. BOX 360900 • CLEVELAND, OHIO 44136

## Free Manuals Download Website

<http://myh66.com>

<http://usermanuals.us>

<http://www.somanuals.com>

<http://www.4manuals.cc>

<http://www.manual-lib.com>

<http://www.404manual.com>

<http://www.luxmanual.com>

<http://aubethermostatmanual.com>

Golf course search by state

<http://golfingnear.com>

Email search by domain

<http://emailbydomain.com>

Auto manuals search

<http://auto.somanuals.com>

TV manuals search

<http://tv.somanuals.com>