

# ALTO-SHAAM®

## Rotisserie

## Electric



**Models:**  
**AR-7EVH**

**ELECTRIC ROTISSERIE WITH VENTLESS HOOD**

- **INSTALLATION**
- **OPERATION**
- **MAINTENANCE**



W164 N9221 Water Street • P.O. Box 450 • Menomonee Falls, Wisconsin 53052-0450 USA  
PHONE: 262.251.3800 • 800.558.8744 USA/CANADA FAX: 262.251.7067 • 800.329.8744 U.S.A. ONLY  
[www.alto-shaam.com](http://www.alto-shaam.com)



Delivery .....	1
Unpacking .....	1
Safety Procedures and Precautions .....	2

### Installation

Site Installation .....	3
Leveling .....	3
Clearance Requirements .....	3
Sound Pressure Levels .....	3
Dimension Drawings .....	4
Product Capacity .....	4
Electrical Connection .....	5
Drip Tray Installation .....	6
Stacking Combinations & Instructions .....	6-7
Options & Accessories .....	8

### Operating Instructions

Start-Up Procedures .....	9
Ventless Hood Control Identification .....	9
Rotisserie Control Identification .....	10
Cooking Procedures - Quick Reference .....	11
Cooking Instructions .....	12
Hold Only Instructions .....	13
Additional Browning Feature .....	14
Preset Menu Key Option .....	15-16
Product Loading .....	17-18
Grease Collection .....	19-20

### Care and Cleaning

Cleaning and Preventative Maintenance .....	21
Protecting Stainless Steel Surfaces .....	21
Cleaning Agents .....	21
Cleaning Materials .....	21
Ventless Hood Cleaning and Maintenance .....	22
Rotisserie Cleaning and Maintenance .....	24
Rotisserie Daily Cleaning .....	24
Daily Gasket Cleaning .....	25
Clean Rotisserie Convection Box .....	25
Check Rotisserie Overall Condition .....	26

### Service

Troubleshooting Guide .....	27
Ventless Hood, Final Floor .....	28
Ventless Hood, Electrical Assembly .....	28
Ventless Hood, Parts List .....	29
Ventless Hood, Full Assembly .....	30
Rotisserie, Bulb Replacement Instructions .....	31
Rotisserie, Final Floor .....	32
Rotisserie, Final Floor Parts List .....	33-34
Rotisserie, Full Assembly & Door Assembly .....	35
Rotisserie, Full & Door Assembly Parts Lists .....	36
Rotisserie, Interior View .....	37
Rotisserie, Electrical Service .....	38
Rotisserie, Replacement of Glass Door .....	39
Rotisserie, Stainless Steel Back Panel .....	40
Grease Collection Unit .....	41

### Wire Diagrams

Always refer to the wire diagram(s) included with the unit for most current version.

### Warranty

Transportation Damage and Claims ..... Back Cover  
Limited Warranty..... Back Cover



## DELIVERY

This Alto-Shaam appliance has been thoroughly tested and inspected to ensure only the highest quality unit is provided. Upon receipt, check for any possible shipping damage and report it at once to the delivering carrier. *See Transportation Damage and Claims section located in this manual.*

This appliance, complete with unattached items and accessories, may have been delivered in one or more packages. Check to ensure that all standard items and options have been received with each model as ordered.

Save all the information and instructions packed with the appliance. Complete and return the warranty card to the factory as soon as possible to ensure prompt service in the event of a warranty parts and labor claim.

This manual must be read and understood by all people using or installing the equipment model. Contact the Alto-Shaam Tech Team Service Department if you have any questions concerning installation, operation, or maintenance.

**NOTE:** All claims for warranty must include the full model number and serial number of the unit.

## UNPACKING

1. Carefully remove the appliance from the carton or crate.

**NOTE:** Do not discard the carton and other packaging material until you have inspected the unit for hidden damage and tested it for proper operation.

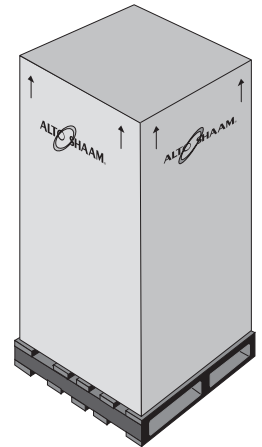

2. Read all instructions in this manual carefully before initiating the installation of this appliance.

**DO NOT DISCARD THIS MANUAL.**

This manual is considered to be part of the appliance and is to be provided to the owner or manager of the business or to the person responsible for training operators. *Additional manuals are available from the Alto-Shaam Tech Team Service Department.*

3. Remove all protective plastic film, packaging materials, and accessories from the appliance before connecting electrical power. Store any accessories in a convenient place for future use.

## SAFETY PROCEDURES AND PRECAUTIONS

Knowledge of proper procedures is essential to the safe operation of electrically and/or gas energized equipment. In accordance with generally accepted product safety labeling guidelines for potential hazards, the following signal words and symbols may be used throughout this manual.

### DANGER



Used to indicate the presence of a hazard that **WILL** cause severe personal injury, death, or substantial property damage if the warning included with this symbol is ignored.

### WARNING



Used to indicate the presence of a hazard that **CAN** cause personal injury, possible death, or major property damage if the warning included with this symbol is ignored.

### CAUTION



Used to indicate the presence of a hazard that can or will cause minor or moderate personal injury or property damage if the warning included with this symbol is ignored.

### CAUTION

Used to indicate the presence of a hazard that can or will cause minor personal injury, property damage, or a potential unsafe practice if the warning included with this symbol is ignored.

**NOTE:** Used to notify personnel of installation, operation, or maintenance information that is important but not hazard related.

1. This appliance is intended to cook, hold or process foods for the purpose of human consumption. No other use for this appliance is authorized or recommended.
2. This appliance is intended for use in commercial establishments where all operators are familiar with the purpose, limitations, and associated hazards of this appliance. Operating instructions and warnings must be read and understood by all operators and users.
3. Any troubleshooting guides, component views, and parts lists included in this manual are for general reference only and are intended for use by qualified technical personnel.
4. This manual should be considered a permanent part of this appliance. This manual and all supplied instructions, diagrams, schematics, parts lists, notices, and labels must remain with the appliance if the item is sold or moved to another location.

### NOTE

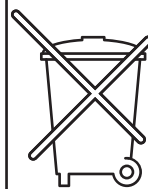

For equipment delivered for use in any location regulated by the following directive:

**DO NOT DISPOSE OF ELECTRICAL OR ELECTRONIC EQUIPMENT WITH OTHER MUNICIPAL WASTE.**

# INSTALLATION

## SITE INSTALLATION

### DANGER



**IMPROPER INSTALLATION, ALTERATION, ADJUSTMENT, SERVICE, OR MAINTENANCE COULD RESULT IN SEVERE INJURY, DEATH, OR CAUSE PROPERTY DAMAGE.**

**READ THE INSTALLATION, OPERATING AND MAINTENANCE INSTRUCTIONS THOROUGHLY BEFORE INSTALLING OR SERVICING THIS EQUIPMENT.**

In order to maintain established National Sanitation Foundation standards, all counter-mounted models must be sealed to the counter with a R.T.V. or silastic meeting N.S.F. requirements or have 6" (152mm) unobstructed clearance at the back and sides of the unit.

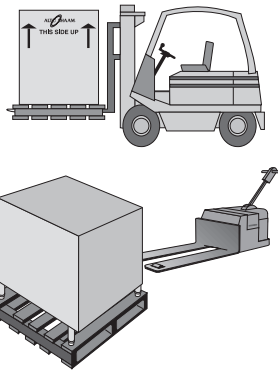

1. The appliance must be installed in a well ventilated room obeying the local ventilation codes and standards and on a non-combustible, level surface.
2. **DO NOT** install this appliance in any area where it may be affected by any adverse conditions such as steam, grease, dripping water, high temperatures, or any other severely adverse conditions.
3. For both safety and convenience, the rotisserie must be installed in a location to provide easy access to the controls and should be positioned at a safe and convenient height to provide easy loading and unloading of hot products.
4. This appliance must be kept free and clear of any obstructions blocking access for maintenance or service.
5. The AR-7EVH can be stacked on top of a matching holding cabinet. Complete stacking instructions are located in this manual.

A number of adjustments are associated with initial installation and start-up. It is important that these adjustments be conducted by a qualified service technician. Installation and start-up adjustments are the responsibility of the dealer or user. These adjustments include but are not limited to thermostat calibration, door adjustment, leveling, electrical hook-up and installation of optional casters or legs.

### CAUTION



**METAL PARTS OF THIS EQUIPMENT BECOME EXTREMELY HOT WHEN IN OPERATION. TO AVOID BURNS, ALWAYS USE HAND PROTECTION WHEN OPERATING THIS APPLIANCE.**

### DANGER



**DO NOT store or use gasoline or other flammable vapors or liquids in the vicinity of this or any other appliance.**

### CAUTION



**TO PREVENT PERSONAL INJURY, USE CAUTION WHEN MOVING OR LEVELING THIS APPLIANCE.**

### LEVELING

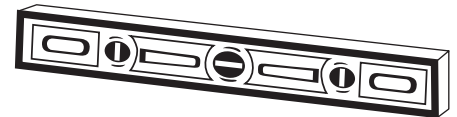

Level the appliance from side-to-side and front-to-back with the use of a spirit level.

We recommend checking the level periodically to make certain the floor has not shifted nor the appliance moved.

**NOTE:** Failure to properly level this appliance can cause improper function.

### MINIMUM CLEARANCE REQUIREMENTS

A 6" (152mm) minimum clearance must be allowed at the back and both sides of the unit. Warranty will become null and void if these directions are not followed.

### SOUND PRESSURE MEASUREMENT

Microphone position	Sound pressure level dBA	
	Without hood system operating	With hood system operating
Front	69	71
Right Side	64.3	67
Left Side	64.3	69
Rear	64.7	68

# INSTALLATION

## SITE INSTALLATION

**DOUBLE PANE CURVED GLASS DOOR**

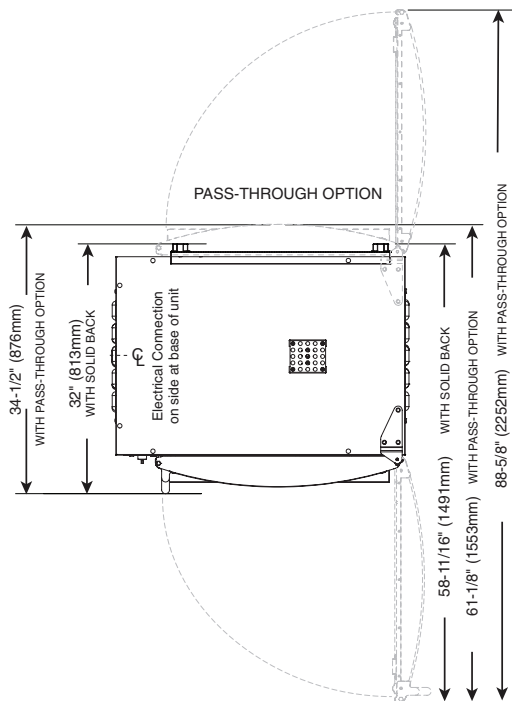

**SINGLE PANE FLAT GLASS DOOR**

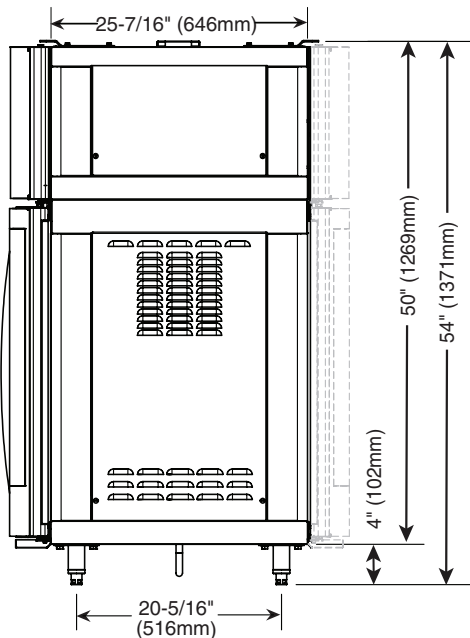
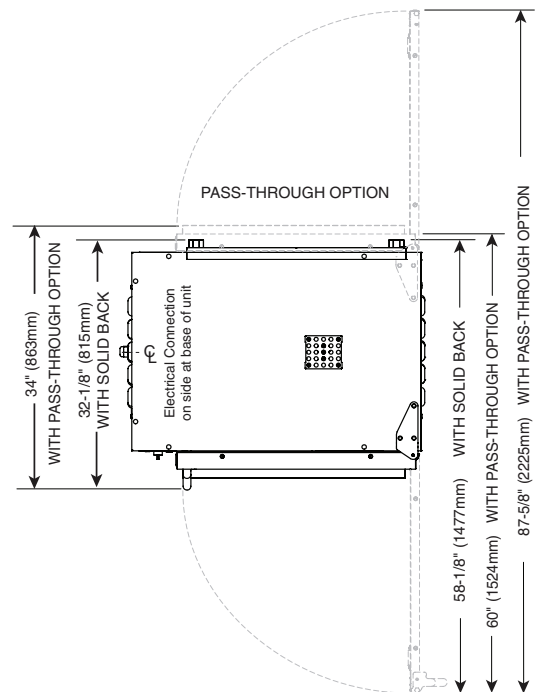

**SIDE VIEW - SOLID BACK**

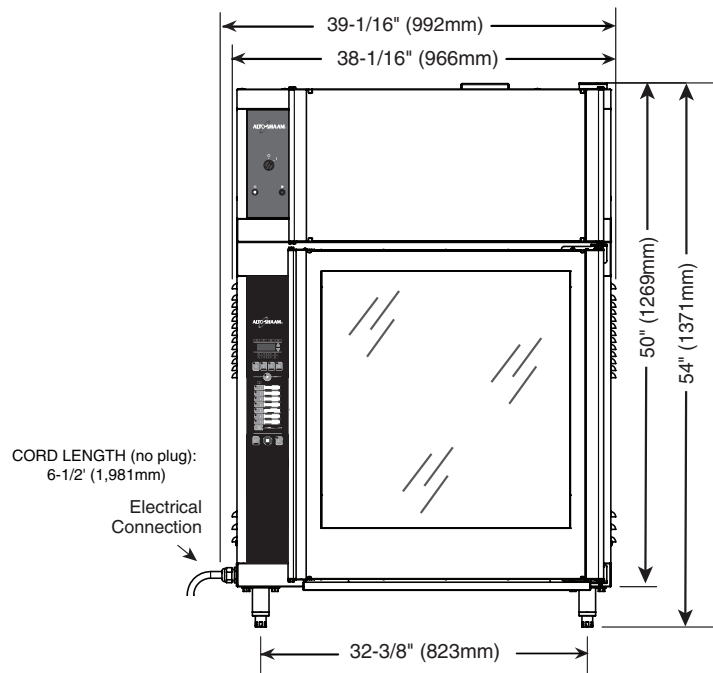

**FRONT VIEW**

**PRODUCT \ PAN CAPACITY**

98 lb (44 kg) MAXIMUM

ANGLED SPITS (STANDARD): (UP TO 7 SPITS CAN BE USED)  
 Up to twenty-one (21) 3-1/2 lb chickens (1,6 kg)  
 Up to twenty-eight (28) 2-1/2 to 3 lb chickens (1,1 to 1,4 kg)

PIERCING SPITS (OPTIONAL): (UP TO 7 SPITS CAN BE USED)  
 Up to twenty-eight (28) 2-1/2 to 3-1/2 lb chickens (1,1 to 1,6 kg)

TURKEY SPIT (OPTIONAL): (UP TO 3 SPITS CAN BE USED) One (1) Turkey up to 25 lb (11 kg) on each spit

# INSTALLATION

## ELECTRICAL CONNECTION

The appliance must be installed by a qualified service technician. The oven must be properly grounded in accordance with the National Electrical Code and applicable local codes.

### DANGER



To avoid electrical shock, this appliance **MUST** be adequately grounded in accordance with local electrical codes or, in the absence of local codes, with the current edition of the National Electrical Code ANSI/NFPA No. 70. In Canada, all electrical connections are to be made in accordance with CSA C22.1, Canadian Electrical Code Part 1 or local codes.



Plug the unit into a properly grounded receptacle **ONLY**, positioning the unit so that the plug is easily accessible in case of an emergency. Arcing will occur when connecting or disconnecting the unit unless all controls are in the "OFF" position.

Proper receptacle or outlet configuration or permanent wiring for this unit must be installed by a licensed electrician in accordance with applicable local electrical codes.

After wiring and power connection has been completed, turn the main power switch to the "ON" position. The main power switch can be left "ON" for daily use, but should be turned "OFF" when cleaning or performing maintenance or repairs to the rotisserie.

### "WARNING" RISK OF FIRE!

Use a UL Listed grounding type plug rated 250 Volts, 50 Amperes, 1 Phase, 3 wire for single phase units and 250 V, 50 A, 3 Phase, 4 wire for three phase units. Plug to be selected and installed only by qualified service personnel. Individual conductors are marked L1, L2, L3 when applicable, N when applicable, and G.

### DANGER



**APPLIANCES WITH NO CORD PROVIDED BY FACTORY MUST BE EQUIPPED WITH A CORD OF SUFFICIENT LENGTH TO PERMIT THE APPLIANCE TO BE MOVED FOR CLEANING.**



**ELECTRICAL CONNECTIONS MUST BE MADE BY A QUALIFIED SERVICE TECHNICIAN IN ACCORDANCE WITH APPLICABLE ELECTRICAL CODES.**

### ELECTRICAL

VOLTAGE	PHASE	CYCLE/HZ	AMPS	kW	
208	1	60	40.0	8.3	BARE END
240	1	60	38.0	8.8	NO PLUG
208	3	60	33.0/ph	8.3	BARE END
240	3	60	32.0/ph	8.8	NO PLUG
380-415 (AGCY)	3	50/60	24.0/ph	8.8	
380	3	50/60	22.0/ph	7.4	NO CORD
415	3	50/60	24.0/ph	8.8	NO PLUG

Wire diagrams are located in the inside access panel of the unit.

### REGARDING INTERNATIONAL STANDARD UNITS:

If the unit is not equipped with flexible cord with plug, an all-pole country approved disconnection device which has a contact separation of at least 3mm in all poles must be incorporated in the fixed wiring for disconnection. When using a cord without a plug, the green/yellow conductor shall be connected to the terminal which is marked with the ground symbol. If a plug is used, the socket outlet must be easily accessible. If the power cord needs replacement, use a similar one obtained from the distributor.

**For CE approved units:** To prevent an electrical shock hazard between the appliance and other appliances or metal parts in close vicinity, an equalization-bonding stud is provided. An equalization bonding lead must be connected to this stud and the other appliances / metal parts to provide sufficient protection against potential difference. The terminal is marked with the following symbol.



**Power Cord Connection:** The side connection is recommended for all applications. If a bottom connection is necessary for counter top units, user will need to provide a cutout in the countertop to allow the cord to hang freely without crimping.

### Hard wired models:

Hard wired models must be equipped with a country certified external allpole disconnection switch with sufficient contact separation.

If a power cord is used for the connection of the product an oil resistant cord like H05RN or H07RN or equivalent must be used.

**NOTE:** Where local codes and CE regulatory requirements apply, appliances must be connected to an electrical circuit that is protected by an external GFCI outlet.



### DANGER



**ENSURE POWER SOURCE MATCHES VOLTAGE IDENTIFIED ON APPLIANCE RATING TAG.**

# INSTALLATION

## DRIP TRAY INSTALLATION

Attach tray using two carriage bolts (A) in base panel. Lift tray up and away to remove.

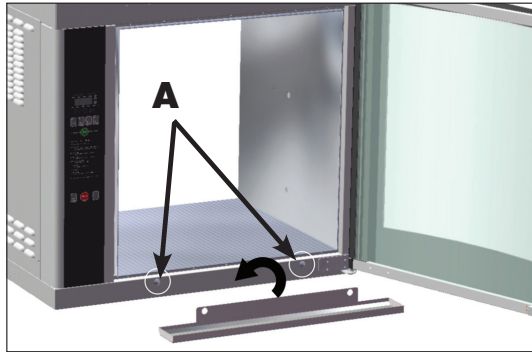

## GREASE COLLECTION UNIT



## STACKING COMBINATIONS & INSTALLATION REQUIREMENTS

### STACKING COMBINATIONS (FACTORY INSTALLED)

AR-7EVH rotisserie with ventless hood *over* AR-7H companion holding cabinet

Requires 6" (152mm) legs with flanged feet 5001761 bolted to the floor.

[OVERALL HEIGHT: 90-13/16" (2307mm)]

## CAUTION



STACKING APPLICATIONS  
OUTSIDE THE U.S. REQUIRE  
FLANGED FEET AND MUST BE  
BOLTED TO THE FLOOR.

## CAUTION



MAKE CERTAIN TO FASTEN  
EACH OF THE FOUR HOLES



## STACKING INSTRUCTIONS

A rotisserie with ventless hood can be stacked on top of a matching holding cabinet.

Only screws, lock washers, and hex nut are required to fasten units together when stacking a rotisserie on top of a matching holding cabinet.

All fastening holes have been prepunched. The stacking combination also requires the minimum clearance of 6-inches (152mm) at the top, back and both sides.

1. Attach 4: Support Brackets (1010092) and any required feet or casters (varies) with 4: SC-2191, 4: WS-2867, and 4: WS-22095 to the bottom unit.
2. Remove the access panels of both units.
3. Punch out the knock out hole (A) in the top panel of the lower unit.
4. Remove power cord from upper unit and discard.
5. The new power cord and strain relief bushing for upper unit should be routed through the knock out hole in the top panel of the lower unit.
6. Carefully lift and place the upper unit into position aligning on bottom unit.
7. Secure units together by inserting a hex head screw and washer inside upper unit, and back them with a washer, lock-washer, and nut inside lower unit. Securely tighten all four screws.
8. Attach a strain relief bushing to the bottom panel of the lower unit to the left of the existing power cord. (B)
9. Route power cord from upper unit through the strain relief bushings, then tighten bushings.
10. Replace the access panels on both units.

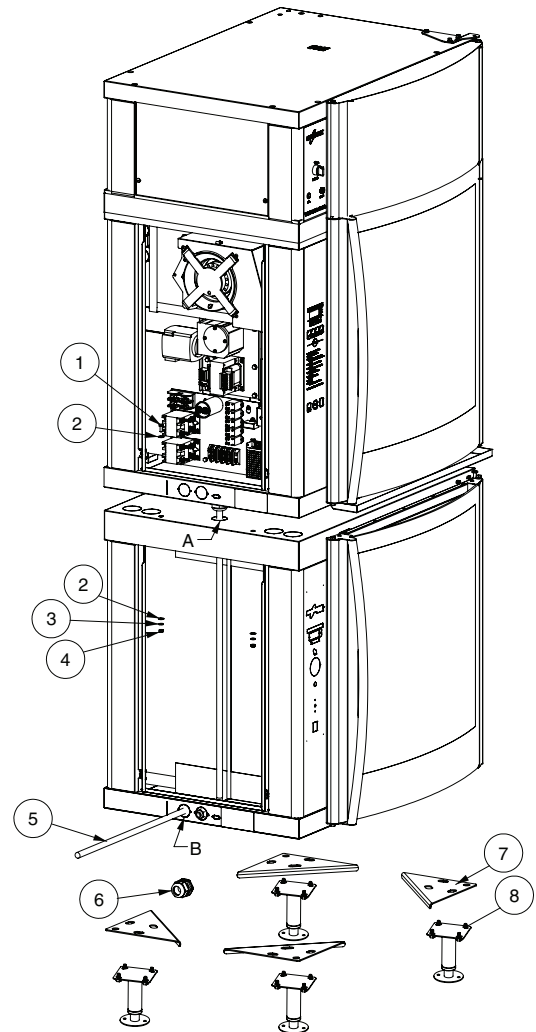

AR-7EVH OVER AR-7H STACKING ASSEMBLY			
ITEM	PART NO.	DESCRIPTION	QTY
1	SC-27385	SCREW, 1/4/20 X 3/4" LG HEX HEAD	4
2	WS-22094	WASHER, 1/4", FLAT, 5/8 OD 18-8 SS	8
3	WS-2294	LOCK WASHER, 1/4"	4
4	NU-2437	NUT, 1/4-20 HEX S/S	4
5	CD-3987	CORD, 8/4 SEEO W-A, 105C, (-50C)	1
6	BU-33948	BUSHING, STRAIN RELIEF, 18MM-25MM AR-7E	1
7	1010092	BRACKET, SUPPORT, BASE	4
8	SC-2191	SCREW, HEX HEAD, 5/16-18 X 1" LONG	16
9*	CR-3801*	CONNECTORS, *CT, RING, 10MM, SQ/M6	4
10*	WS-22095	WASHER, 3/8" ID, 1" OD, FLAT, 18-8 SS	16
11*	WS-2867	LOCK WASHER, 5/16"	16

\*NOT SHOWN

# INSTALLATION

## OPTIONS & ACCESSORIES

DESCRIPTION	PART NO.
DOOR HANDLE	NON-CONTROL SIDE HD-26900
DRIP PAN, STAINLESS STEEL	WITHOUT DRAIN 1001976
FEET, RUBBER, 2" (51mm) FOR COUNTER TOP UNITS ONLY (NOT AVAILABLE ON MODELS BUILT FOR US OR CANADA)	CE ONLY 5001614
GREASE COLLECTION UNIT	NOT AVAILABLE ON STACKED UNITS 5012800
LEGS	ASSEMBLY, 6" (152mm) 5001414
	ASSEMBLY, FLANGED FEET, 6" (152mm) (REQUIRED FOR STACKING UNITS) 5001761
MULTI-PURPOSE WIRE BASKET (.50 DIAMETER PIN)	BS-26019
SPITS	ANGLED SPIT, STAINLESS STEEL (7 STANDARD WITH UNIT) SI-25934
	PIERCING SPIT, STAINLESS STEEL SI-25729
	TURKEY SPIT, STAINLESS STEEL 5011681
	ANGLED SPIT, TEFLON COATED 5001335
<b>STACKING ASSEMBLY (FACTORY INSTALLED)</b>	
AR-7EVH OVER AR-7H	(208-240V, 1PH) 5008787
	(208-240V, 3PH) 5008948
	(380-415V) 5008922
STANDS	AR-7EVH w/ SHELF [35-15/16" x 39-3/16" x 27-1/2" (912mm x 995mm x 700mm)] FR-26550
	AR-7EVH OVER 750-S, [36" x 39-3/16" x 27-9/16" (914mm x 995mm x 700mm)] 5002058
TEFLON® COATED ACCESSORY PACKAGE	COMMERCIAL GRADE, INCLUDES DISKS, DRIP TRAY AND 7 ANGLED SPITS 5001302
VENTLESS HOOD REPLACEMENT FILTERS	GREASE FILTER FI-25867
	CHARCOAL FILTER FI-25866

# OPERATING INSTRUCTIONS

## START-UP

1. Before operating the unit, become familiar with the operation of the controls. Read this manual carefully and retain it for future reference.
2. Ensure the filters inside the hood are correctly in place and the door is closed.
3. Turn on the hood by turning the **power switch** ① to the "I" position
  - Note that the **fan indicator light** ② will illuminate while running.
4. Wait 5 seconds and press the **reset button** ③ to allow the rotisserie to be turned on.
5. Continue with the operation instructions for the rotisserie on page 10.

## ATTENTION

**HOOD AND ROTISSERIE WILL NOT OPERATE UNLESS FILTERS ARE IN PLACE.**



## VENTLESS HOOD CONTROL IDENTIFICATION

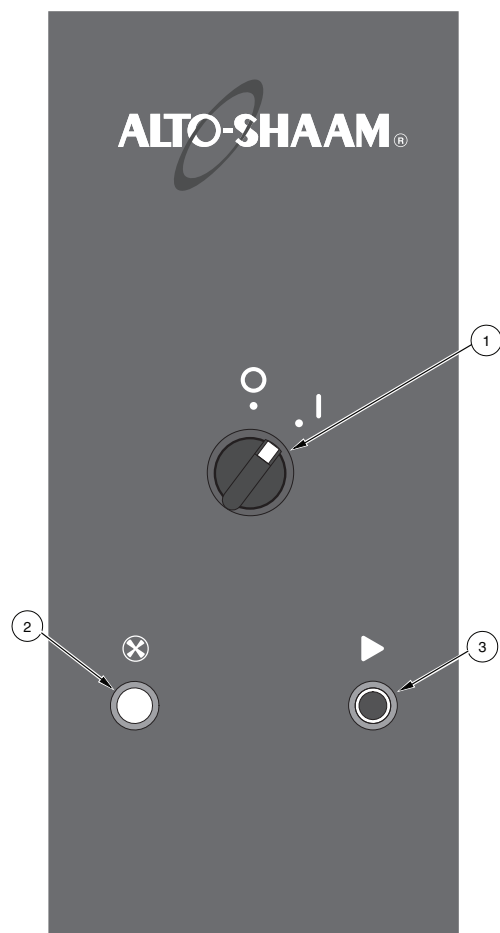

1	POWER SWITCH
2	FAN INDICATOR LIGHT
3	RESET BUTTON



## DANGER



**DISCONNECT UNIT FROM POWER SOURCE BEFORE CLEANING OR SERVICING.**

## CAUTION

**THE EDGES INSIDE THE HOOD HOUSING CAN BE SHARP. USE CAUTION WHEN REMOVING OR REPLACING FILTERS.**

# OPERATING INSTRUCTIONS

## ROTISSERIE CONTROL IDENTIFICATION

**ALTO-SHAAM®**

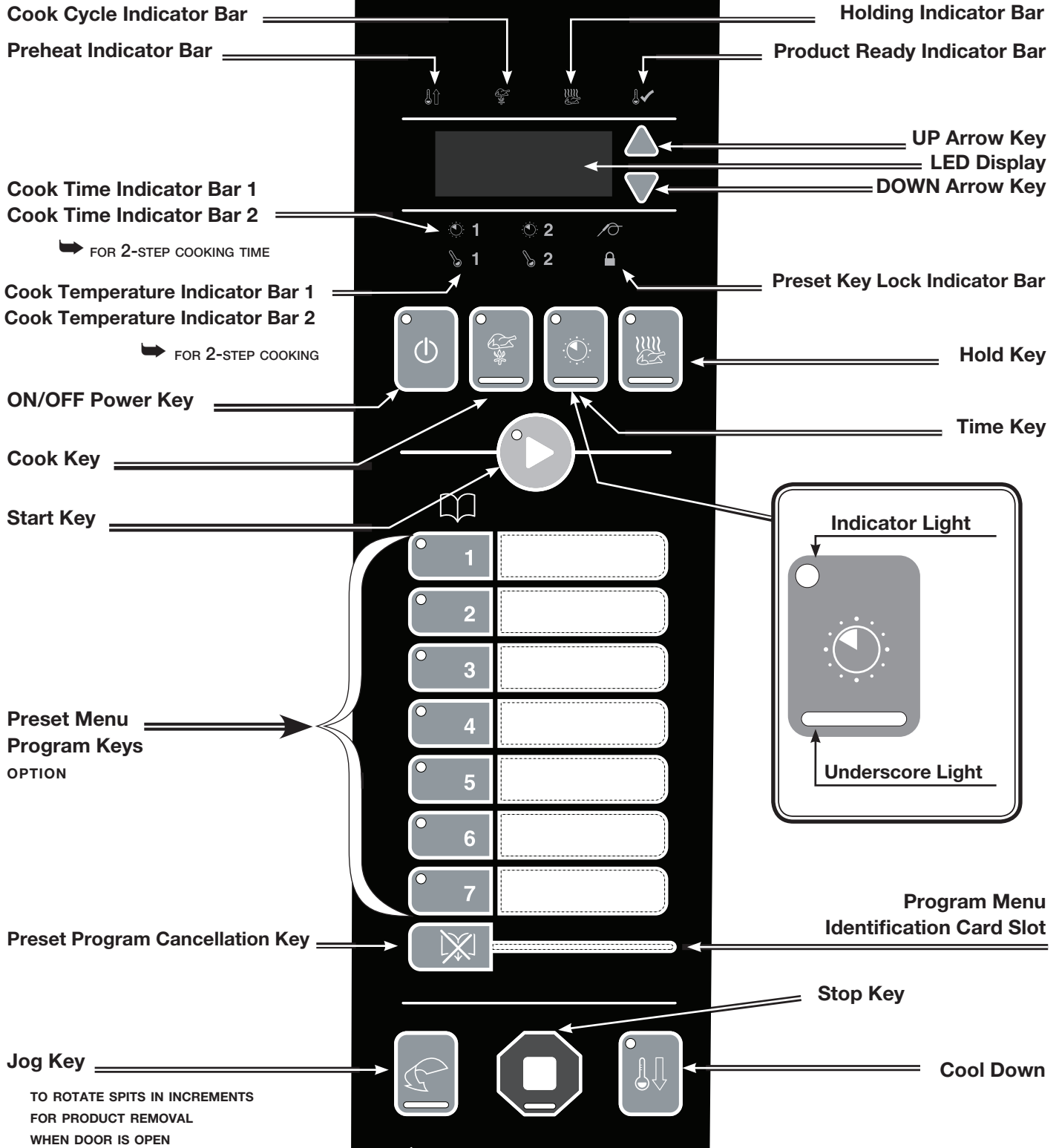

# QUICK REFERENCE OPERATION

## ALLOW THE ROTISSERIE TO PREHEAT

LOAD PRODUCT WHEN OVEN BEEPS AT REGULAR INTERVALS AND THE START KEY AND READY INDICATOR BEGIN FLASHING

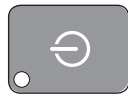

**ON/OFF Key**

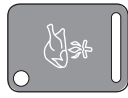

**COOK Key**

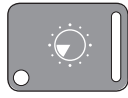

**TIME Key**

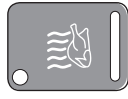

**HOLD Key**



**START Key**



**Ready Indicator**

1. Press the **ON/OFF** key.
2. Press and set the **COOK** key.
3. Press and set the **COOK** key for 2-step cooking.
4. Press and set the **TIME** key.
5. Press and set the **TIME** key for 2-step cooking.
6. Press and set the **HOLD** key.
7. Press the **HOLD** key again to add browning time.
8. **When preheated:** Load product & press start.

ITEM	CHICKEN, HALVES OR PIECES	CHICKEN, WHOLE	TURKEY BREAST	PORK RIBS	PORK LOIN, BONELESS	LAMB LEG, BONELESS
<b>SIZE OF MEAT</b>	2-1/2 to 3 lb (1,1 to 1,4 kg)	2-1/2 to 3 lb (1,1 to 1,4 kg)	5-1/2 lb (2,5 kg)	2-3/4 down	5 to 7 lb (2,3 to 3,2 kg)	8 to 11 lb (4 to 5 kg)
<b>CAPACITY PER SPIT/BASKET</b>	8 pieces	3-4 chickens	1 turkey breast	2 full slabs	1 to 2 pork loins	1 lamb leg
<b>SUGGESTED SPIT</b>	BASKET	STANDARD OR PIERCING SPIT	BASKET OR PIERCING	BASKET	BASKET	BASKET OR PIERCING
<b>COOK TEMP 1</b>	425°F (218°C)	400°F (204°C)	250°F (121°C)	250°F (121°C)	250°F (121°C)	250°F (121°C)
<b>COOK TEMP 2</b>	NOT REQUIRED	NOT REQUIRED	400°F (204°C)	375°F (191°C)	350°F (177°C)	350°F (177°C)
<b>COOK TIME 1</b>	30 minutes (20 min for long-term holding)	45 minutes	1-1/2 hours	40 minutes	1 hour	1-1/2 hours
<b>COOK TIME 2</b>	NOT REQUIRED	NOT REQUIRED	15 minutes	5 minutes	15 minutes	15 minutes
<b>HOLD TEMP</b>	160°F (71°C)	160°F (71°C)	165°F (74°C)	150°F (66°C)	160°F (71°C)	150°F (66°C) (medium doneness)
<b>BROWNING TIME</b>	NOT REQUIRED	5 minutes	NOT REQUIRED	15 minutes	NOT REQUIRED	15 minutes
<b>FINAL INTERNAL TEMP</b>	185°F (85°C)	185°F (85°C)	180°F (82°C)	160° to 170°F (71° to 77°C)	155° to 165°F (68° to 74°C)	145° to 150°F (63° to 66°C)

# OPERATING INSTRUCTIONS

## COOKING INSTRUCTIONS



### Press the ON/OFF key.

1. The on/off indicator light will illuminate.
2. The display will show the last set holding temperature.
3. The hold indicator will illuminate.
4. The rotisserie will begin to preheat to the holding temperature shown in the display.



### Press the COOK key.

1. The COOK and the TIME underscore lights will alternately illuminate.
2. The display will indicate the last set cooking temperature when the COOK underscore light is illuminated.
3. The display will indicate the last set cooking time when the TIME underscore light is illuminated.
4. Cook temperature indicator bar will illuminate for:

COOK TEMPERATURE 1

5. If 2-step cooking is required press the COOK key again



Cook temperature indicator bar will illuminate for:

COOK TEMPERATURE 2



#### To change the displayed temperature:

After pressing the COOK key, press the up and down arrow key when COOK TEMPERATURE 1 or COOK TEMPERATURE 2 is illuminated.



### Press the TIME key.

1. The TIME underscore light will illuminate.
2. The display will indicate the last set cooking time when the TIME underscore light is illuminated.
3. The display will indicate the last set cooking temperature when the COOK underscore light is illuminated.

4. Time indicator bar will illuminate for:

TIME 1



5. If 2-step cooking is required press the TIME key again

Time indicator bar will illuminate for:

TIME 2



#### To change the displayed time:

After pressing the TIME key, press the up and down arrow key when TIME 1 or TIME 2 is illuminated.

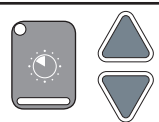

### Press the HOLD key.

1. The HOLD underscore light will illuminate.
2. The display will indicate the last set holding temperature.

#### To change the holding temperature:

After pressing the HOLD key, press the up and down arrow key when the HOLD underscore light is illuminated.



- Product programming can be considered complete after the holding temperature has been set or additional browning time can be added if desired.
- Automatic holding time will activate when the cooking cycle time and any additional browning time has elapsed and the PRODUCT READY BAR is illuminated.
- The product will continue to cook as it decreases from the cooking temperature to the holding temperature. For best results, always allow for product temperature override.



#### To stop a cooking program early and continue to hold:



**Press stop**  
The Rotisserie will stop



**Press On/Off**  
The rotisserie will continue in the hold mode



**Press Start**  
The rotisserie will begin to rotate and hold at the set temperature

# OPERATING INSTRUCTIONS

## HOLD ONLY INSTRUCTIONS

Hold with rotisserie can be set in the power on hold mode or if the operator wants to stop a cooking procedure but continue holding with rotisserie.



### Press the ON/OFF key.

1. The on/off indicator light will illuminate.
2. The display will show the last set holding temperature.
3. The hold indicator will illuminate.
4. The rotisserie will begin to preheat to the holding temperature shown in the display.



### Press the HOLD key.

1. The HOLD underscore light will illuminate.
2. The display will indicate the last set holding temperature.

#### To change the holding temperature:

After pressing the HOLD key, press the up and down arrow key when the HOLD underscore light is illuminated.

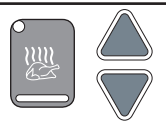

### Press the START key.

The rotisserie will begin to rotate and hold at the set temperature

### To stop a cooking program early and continue to hold:



**Press stop**  
The Rotisserie will stop



**Press On/Off**  
The rotisserie will continue  
in the hold mode



**Press Start**  
The rotisserie will begin to rotate  
and hold at the set temperature

# OPERATING INSTRUCTIONS

## ADDITIONAL BROWNING FEATURE

The control allows the operator to set a specific period of time for additional browning between the end of the COOK TIME and the illumination of the PRODUCT READY BAR at the end of the cooking cycle. Browning time is to be added during initial product programming.



Press the HOLD key.

1. The HOLD underscore light will illuminate.
2. The display will indicate the last browning time.

### To change the browning time:

After pressing the HOLD key, press the up and down arrow key when the browning time appears in the display. **Note:** To disable the browning feature set the time to ":00"



### AVERAGE BROWNING TIME FOR MOST PRODUCTS IS BETWEEN 5 AND 20 MINUTES

- If a browning time has been set, only the radiant heaters will operate.
- **NOTE:** The product will continue to cook as it decreases from the cooking temperature to the holding temperature. For best results, always allow for product temperature override.
- The PRODUCT READY BAR will illuminate at the end of the set browning time and the oven temperature will decrease to the set holding temperature in the automatic hold mode.



THE ROTISSERIE WILL CONTINUE TO PREHEAT UNTIL THE COOK TEMPERATURE IS REACHED.

ALWAYS ALLOW THE ROTISSERIE TO PREHEAT TO THE FULL SET COOKING TEMPERATURE.

When fully preheated, the START key and the PRODUCT READY BAR will flash and the control will beep four times



LOAD PRODUCT PRESS START



- The spit motor will begin to rotate.
- The display will alternate between showing the set cook temperature and set cook time.

When the cooking time and any additional set browning time is complete, the PRODUCT READY BAR will illuminate to indicate the end of the cooking function.

▶ ▶ ▶ AUTOMATIC HOLDING TIME WILL ACTIVATE. ◀ ◀ ◀

- The display will alternate between the set holding temperature and the elapsed holding time since READY.

To stop a cooking program early and continue to hold:



Press stop  
the Rotisserie will stop



Press On/Off  
The rotisserie will continue  
in the hold mode



Press Start  
The rotisserie will begin to rotate  
and hold at the set temperature



# OPERATING INSTRUCTIONS

## PRESET MENU KEY OPTION

The Alto-Shaam rotisserie provides the operator with the ability to set as many as seven cooking programs. Each cooking program can be preset to include all cooking and holding functions. Cooking programs are stored and recalled using the PRESET Keys labeled 1 through 7.

### PROGRAMMING A COOKING PROGRAM:



With the rotisserie oven in the "OFF" position, determine the food product procedure to be programmed. Press and release control ON/OFF key. The oven will beep for one second and power to the unit will be indicated by an illuminated green indicator light located in the upper left corner of the ON/OFF key. The oven will begin operating in the hold mode. The amber hold indicator will be illuminated and the last set hold temperature will be displayed.

---

### ENTER ALL COOKING AND HOLDING PARAMETERS FOR THE PRODUCT SELECTED AS INSTRUCTED ON THE PREVIOUS PAGE.

---

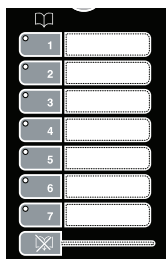

Select a number for the programmed product. Press and hold the selected PRESET number key until you hear an audible signal which will occur within 3 seconds. The number key program indicator light will illuminate. The programmed product is now stored in memory on the specific number key selected.

---

**NOTE:** The last PRESET Key programmed will be the oven cooking run sequence for the next product to be programmed. Settings can be manually changed for the next product and an alternate pre-programmed letter key selected.

---

### TO COOK WITH PRESET MENU KEYS:



#### PRESS AND RELEASE CONTROL ON/OFF KEY.

- The control will beep and the green indicator light on the ON/OFF key will illuminate.
- The amber hold indicator will illuminate.
- The oven will begin operating in the hold mode.
- The previously set hold temperature will be displayed.
- The green indicator will illuminate on all programmed PRESET Keys.

#### PRESS DESIRED PRESET KEY (1 THROUGH 7)

- The Pre-Heat indicator will illuminate.
  - ➔ The rotisserie oven will automatically preheat to the cooking temperature programmed.
- The oven will beep when preheated and the preheat indicator will go out.
- Both the Ready and Start indicator lights will flash.
  - ➔ The set cook temperature will be maintained by the oven and appear in the display while in the ready/start mode.

**NOTE:** Presets cannot be modified once selected. If a modification is desired, the preset must be erased and re-saved.

### LOAD THE PREPARED PRODUCT SPITS INSIDE OVEN AND CLOSE THE OVEN DOOR.

PRESS AND RELEASE THE START KEY.



---

**NOTE:** The rotisserie will beep 4 times when cooking is finished.

---

# OPERATING INSTRUCTIONS

## ATTENTION

After programming a specific product into memory on a preset key number, it is suggested the product be identified by inserting a label in the Program Menu Identification Card Slot.

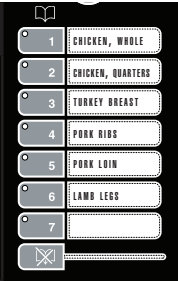

## TO ERASE A PRESET

To erase a preset, the oven must be in either the power-up hold mode or in the preheat mode. The oven cannot be in a cook or automatic hold.

When the oven is in the power-up hold mode or in the preheat mode, press and hold both the **CANCEL** key and the appropriate number **PRESET** key to be erased. The preset indicator light will go out once the preset is erased.



CANCEL key



preset indicator light

## PRESET MENU LOCK AND UNLOCK

The preset menu keys can be locked at any time in order to prevent inadvertent or accidental setting changes.

To lock the preset keys, press the **UP ARROW** key along with the **ON/OFF** Key. The rotisserie will beep and the **preset lock indicator** will illuminate. Release all keys. The rotisserie presets are now locked.



preset lock indicator

To unlock the preset keys, press the **DOWN ARROW** key along with along with the **ON/OFF** Key. The rotisserie will beep twice and the preset lock indicator will extinguish. Release all keys. The preset keys are now unlocked and ready for programming.

## FAHRENHEIT OR CELSIUS SELECTION

With the control off, **press and hold** the **UP ARROW** key for 2 seconds to display the current temperature scale. Toggle between °F and °C by pressing either the up or down arrow key while the temperature scale is displayed on the screen.

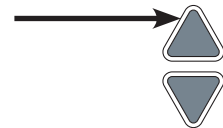

The new scale will save when the screen clears or the On/Off key is pressed.

## COOL DOWN

To cool down the unit:



- Press the Stop button
- Press the **COOL DOWN** key. The fan will turn on. The display will cycle between "Cool" and the internal cavity temperature.

**NOTE:** If the door is closed, the display will show "oPEn door" instead of "Cool".

- Press the **STOP** button again to cancel the cool down process.

## WARNING



**THE CONVECTION FAN CONTINUES TO ROTATE DURING THE COOL DOWN PROCESS. DO NOT OPEN THE PANEL WHILE COOLING DOWN THE ROTISSERIE OVEN.**

# OPERATING INSTRUCTIONS

## PRODUCT LOADING

### STANDARD SPITS

Each of the seven rotisserie spits includes two welded prongs on the square end and one welded, ridged prong on the tapered end. Insert the two-prong, square end into the two holes indicated on the disk assembly drive wheel in the drawing. Insert the tapered, ridged-prong end into the top hole indicated on the opposite side and maneuver until the ridge catches in the hole. After placing one spit into the oven, rotate the rotisserie using the jog button as shown to load every other position. Continue loading the spits one at a time. This is done to maintain balance within the rotisserie.

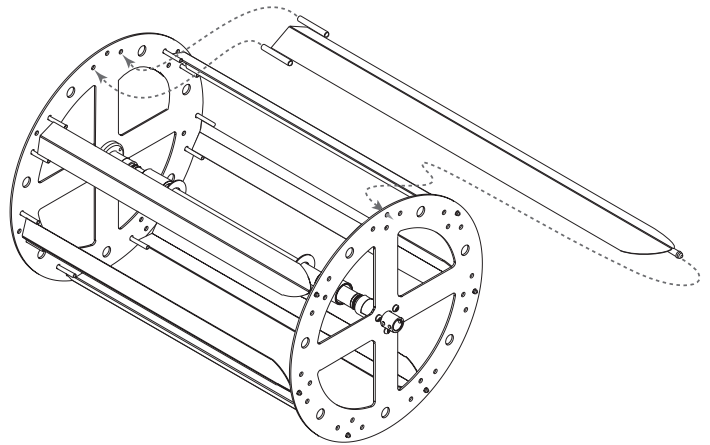
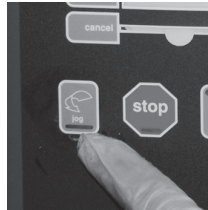

### OPTIONAL SPITS/BASKETS

When optional spits are used, insert the spits in the drive wheel as indicated in the illustration.

When inserting the basket, put the smooth pin (A) end in first. When removing the basket, the machined pin (B) comes out first.

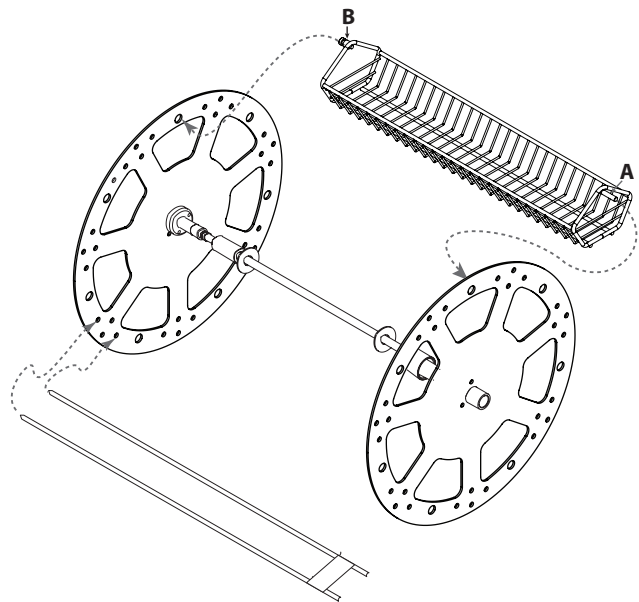

### IMPORTANT NOTE:

When using a partial quantity of standard or optional spits, space the spits evenly as possible around the drive wheel to maintain balance and even rotation.

### SPECIAL ATTENTION:

A combination of standard, piercing, and basket spits can be used at the same time but **NOT** in every spit insertion position. The use of a spit in every position will interfere with the free rotation of the baskets. Using a combination of spits can only be accomplished at significantly reduced rotisserie capacity.

# OPERATING INSTRUCTIONS

## PRODUCT LOADING

### STANDARD SPIT

Insert whole chickens with the legs toward the square end of the spit. Load up to 3, 3-1/2 lb (1,6 kg) chickens per spit for a total of 21 chickens or 4, 2-1/2 lb (1,1 kg) chickens for a total of 28 whole chickens.

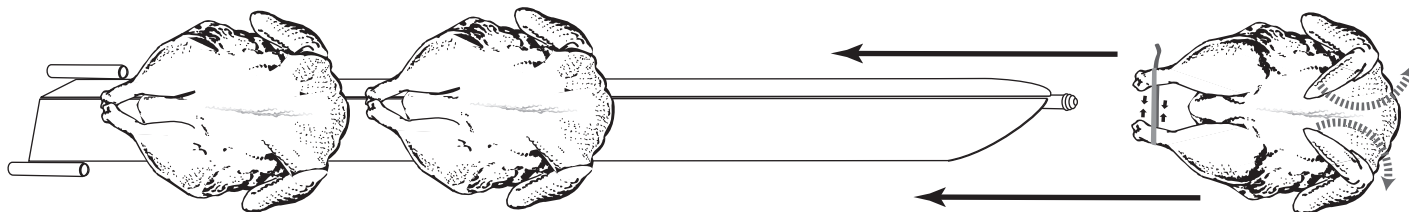

### PIERCING SPIT (OPTION)

The optional piercing spit (Item SI-25729) will accommodate 4, 2-1/2 lb (1,1 kg) to 3-1/2 lb (1,6 kg) whole chickens per spit.

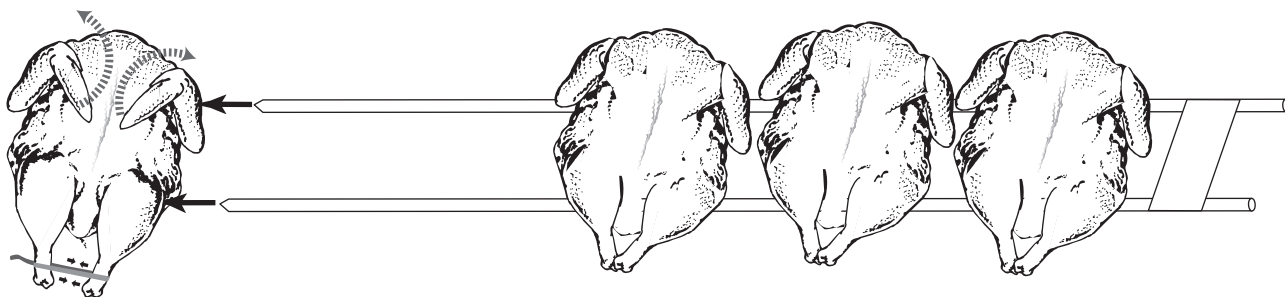

### BASKET SPIT (OPTION)

Basket spits (Item BS-26019 with .50 diameter pin) are useful for irregular size products, denser items, or heavier products that need more support than the piercing spits.

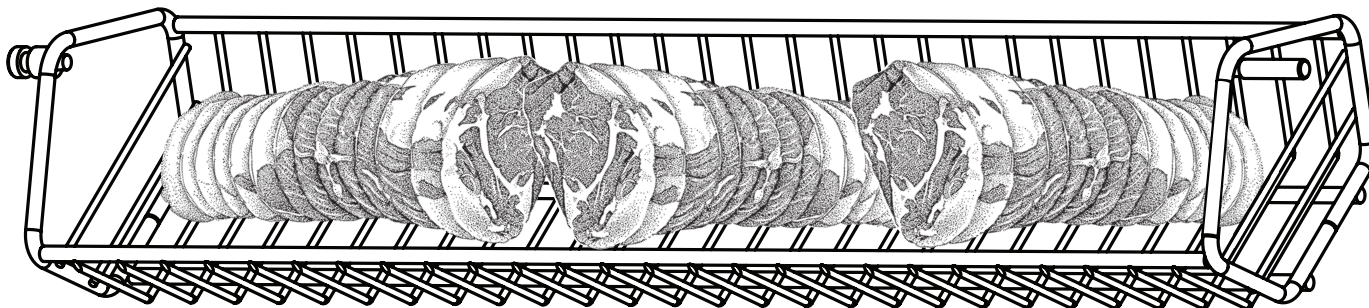

### Turkey SPIT (option)

Insert whole turkey with legs towards the stop plate of the spit (Item 5011681) and slide in stopping tab to keep turkey in position. Load up to 1, 25 lb (11,4 kg) turkey per spit. Use up to three turkey spits per cavity for a total of 3 whole turkeys.

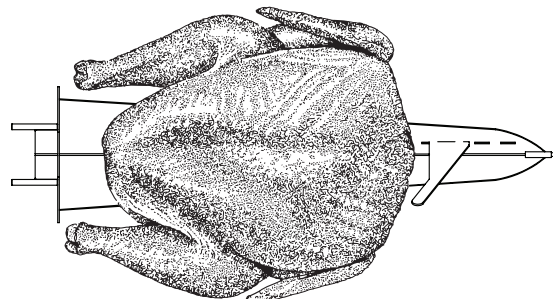

# OPERATING INSTRUCTIONS

## GREASE COLLECTION PROCEDURES

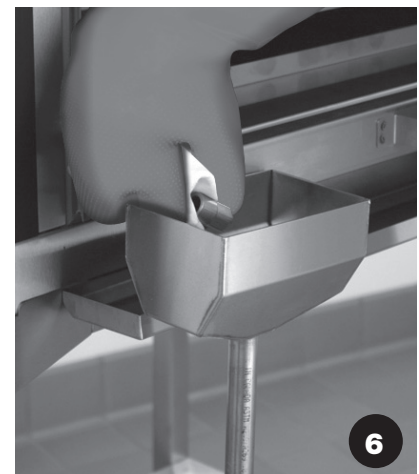
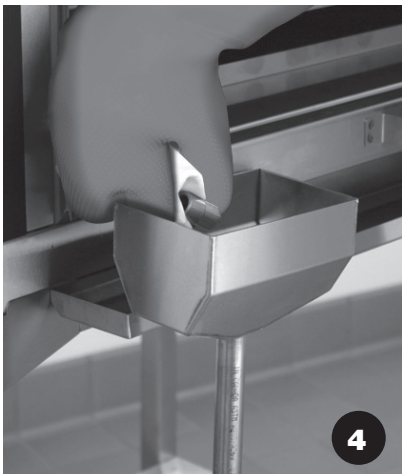

- 1.** Open oven door and pull bottom grease tray forward by pulling on the handle. Pull tray forward only until it engages with the automatic stop mechanism. **DO NOT** pull tray out farther than mechanism will allow.
- 2.** Position rolling grease collection unit in front of oven by pulling it forward. Turn and loosen black release knob to extend the telescoping funnel upward. Ensure top funnel cup is directly under the grease tray spout.
- 3.** Position telescoping funnel behind elbow drain. Tighten black release knob to lock into place.
- 4.** Wearing heat resistant gloves, turn the grease tray spout until the open end is pointing into the drain cup. Open end of spout should be pointing downwards at the 6:00 position. \*Use caution as hot grease will begin draining from the grease tray spout into the grease collection cup.
- 5.** Allow liquid and grease from oven grease tray to drain completely into the grease collection cup. Must allow grease to completely stop flowing and dripping.
- 6.** Wearing heat resistant gloves, turn the grease tray spout until the open end is pointing up and no more grease can drain from it. Open end of the spout should be pointing upwards to the 12:00 position.

# OPERATING INSTRUCTIONS

## GREASE COLLECTION PROCEDURES

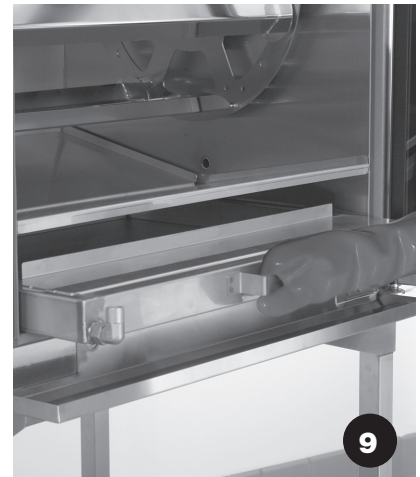

- 7.** Turn and loosen black release knob and gently guide the telescoping funnel downward.
- 8.** Telescoping funnel should be lowered to the level at which it stops without applying force. When properly lowered the funnel will fit under the oven unit.
- 9.** Push grease tray back into oven and close oven door. Wipe any drippings with a wet cloth from the front of the tray and oven.
- 10.** Check grease level in the rolling grease collection unit after every drain cycle. Using handle at front of rolling grease collection unit, lift lid of unit to observe grease level. If grease level is half full or more, the unit must be emptied into the building grease collection tank or dumpster.
- 11.** Return the rolling grease collection unit to its original position by rolling it completely under the electric rotisserie oven.

# CARE AND CLEANING

## CLEANING AND PREVENTATIVE MAINTENANCE

### PROTECTING STAINLESS STEEL SURFACES



It is important to guard against corrosion in the care of stainless steel surfaces. Harsh, corrosive, or inappropriate chemicals can completely destroy the protective surface layer of stainless steel. Abrasive pads, steel wool, or metal implements will abrade surfaces causing damage to this protective coating and will eventually result in areas of corrosion. Even water, particularly hard water that contains high to moderate concentrations of chloride, will cause oxidation and pitting that result in rust and corrosion. In addition, many acidic foods spilled and left to remain on metal surfaces are contributing factors that will corrode surfaces.





Proper cleaning agents, materials, and methods are vital to maintaining the appearance and life of this appliance. Spilled foods should be removed and the area wiped as soon as possible but at the very least, a minimum of once a day. Always thoroughly rinse surfaces after using a cleaning agent and wipe standing water as quickly as possible after rinsing.

### CLEANING AGENTS

Use non-abrasive cleaning products designed for use on stainless steel surfaces. Cleaning agents must be chloride-free compounds and must not contain quaternary salts. Never use hydrochloric acid (muriatic acid) on stainless steel surfaces. Always use the proper cleaning agent at the manufacturer's recommended strength. Contact your local cleaning supplier for product recommendations.

### CLEANING MATERIALS

The cleaning function can usually be accomplished with the proper cleaning agent and a soft, clean cloth. When more aggressive methods must be employed, use a non-abrasive scouring pad on difficult areas and make certain to scrub with the visible grain of surface metal to avoid surface scratches. Never use wire brushes, metal scouring pads, or scrapers to remove food residue.

 <b>CAUTION</b>	
 NO SCRAPERS	<b>TO PROTECT STAINLESS STEEL SURFACES, COMPLETELY AVOID THE USE OF ABRASIVE CLEANING COMPOUNDS, CHLORIDE BASED CLEANERS, OR CLEANERS CONTAINING QUATERNARY SALTS. NEVER USE HYDROCHLORIC ACID (MURIATIC ACID) ON STAINLESS STEEL. NEVER USE WIRE BRUSHES, METAL SCOURING PADS OR SCRAPERS.</b>
 NO WIRE BRUSHES	
 NO STEEL PADS	

# CARE AND CLEANING

## HOOD CLEANING & MAINTENANCE

To ensure optimum performance from the ventless hood, it is important to establish and maintain a regular cleaning and maintenance schedule. Use of the cleaning and maintenance reminder form is highly recommended.



**Note:** If cleaning is not performed according to the instructions a fire may occur.

Access to the internal components, safety switches, filters, etc., are gained by opening the access door. A metal grease filter and charcoal filter are located immediately inside the hood access door.

To help maintain the protective film coating on polished stainless steel, clean the exterior of the cabinet with a cleaner recommended for stainless steel surfaces. Spray the cleaning agent on a clean cloth and wipe with the grain of the stainless steel.

**NOTE:** Never use hydrochloric acid (muriatic acid) on stainless steel.

### ATTENTION

**HOOD AND ROTISSERIE WILL NOT OPERATE UNLESS FILTERS ARE IN PLACE.**

### CHARCOAL FILTER

The charcoal (odor and pollution control filter) is located immediately inside the hood access door. The charcoal filter should be inspected for contaminants on a regular basis. **Replacement must be made at a minimum of three-month intervals or more often if heavy contaminants are visible or if the filter no longer controls odors, which ever happens first.** To remove the filter, grasp on both ends and pull out from the front of the hood.

**WHEN REPLACING THE FILTER, MAKE CERTAIN THE AIR FLOW ARROW POINTS TOWARD THE HOOD FAN. MAKE CERTAIN THE FILTER IS REPLACED IN THE FOUR-SIDED METAL FRAME PROVIDED WITH THE HOOD.**

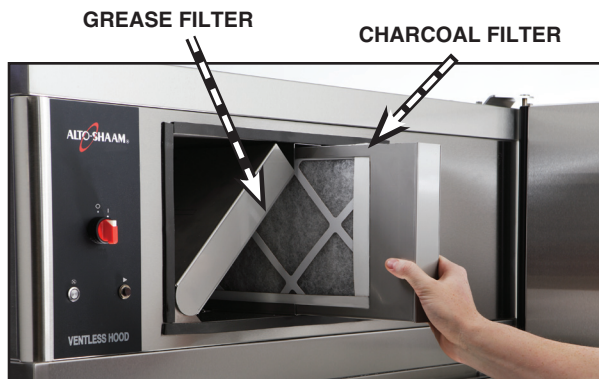

## DANGER



**AT NO TIME SHOULD THE INTERIOR OR EXTERIOR BE STEAM CLEANED, HOSED DOWN, OR FLOODED WITH WATER OR LIQUID SOLUTION OF ANY KIND. DO NOT USE WATER JET TO CLEAN.**



**SEVERE DAMAGE OR ELECTRICAL HAZARD COULD RESULT.**

**WARRANTY BECOMES VOID IF APPLIANCE IS FLOODED**



## DANGER



**DISCONNECT UNIT FROM POWER SOURCE BEFORE CLEANING OR SERVICING.**

### GREASE FILTERS & METAL HOUSING (PLENUM)

The metal grease filter is located immediately inside the hood. Cleaning frequency should be based on oven usage. Grease-laden products such as red meat, poultry, etc., require cleaning frequency of at least once a week. Remove the grease filter by pulling it straight out of the housing from the front access. Place the filter in the dishwasher or wash separately by placing in hot, soapy water until all grease and particles have been removed. Rinse thoroughly. Allow the filter to air dry before reinstalling.

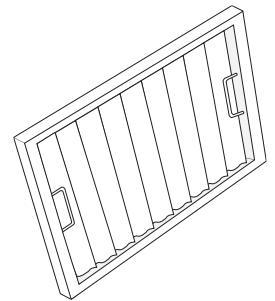

Clean the interior metal housing (plenum) with a damp cloth and any good commercial detergent or grease solvent at the recommended strength. Avoid the use of abrasive cleaning compounds, chloride-based cleaners, or cleaners containing quaternary salts. Use a degreasing agent if necessary.

## CAUTION

**THE EDGES INSIDE THE HOOD HOUSING CAN BE SHARP. USE CAUTION WHEN REMOVING OR REPLACING FILTERS.**



## HOOD CLEANING & MAINTENANCE

**When performing replacement of filters at minimum 3 month OR when heavy contamination is found (which ever happens first), it is recommended that the exhaust tube be cleaned.** To clean insert a flexible wire brush with the recommended cleaning solution as specified in this manual into both sides of the exhaust tube and scrub until any grease buildup is removed.

**NOTE:** liquid cleaner may be sprayed into the exhaust tube as needed before applying the brush. Consult the cleaning section of this manual (following pages) for approved cleaners.

1. Insert the brush into the two lower exhaust openings (one at a time) as far as possible Figure 1.
2. Work the brush in and out as indicated by the arrows above in Figure 2 to remove any grease/debris from the exhaust tube.
3. Repeat with the exhaust tube opening located inside the hood cavity Figure 3.

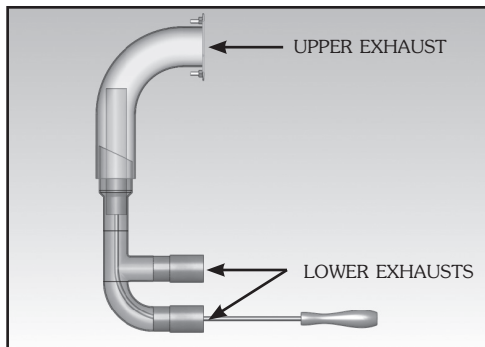

**Figure 1** Exhaust tube only - unit removed for clarity

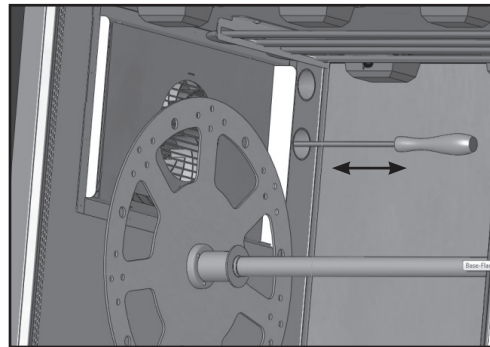

**Figure 2**

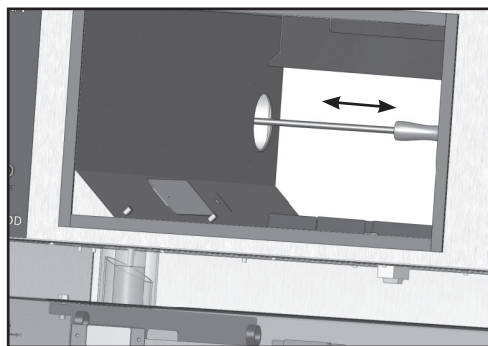

**Figure 3**

# CARE AND CLEANING

## ROTTISSERIE CLEANING & MAINTENANCE

### EQUIPMENT CARE

Under normal circumstances, this oven should provide you with long and trouble free service. There is no preventative maintenance required, however, the following Equipment Care Guide will maximize the potential life and trouble free operation of this oven. The cleanliness and appearance of this equipment will contribute considerably to operating efficiency and savory, appetizing food. Good equipment that is kept clean works better and lasts longer.



## DANGER



**DISCONNECT UNIT FROM POWER SOURCE BEFORE CLEANING OR SERVICING.**

### CLEAN ROTTISSERIE DAILY

1. Press the electrical power switch to the "OFF" position.
2. Allow rotisserie surfaces to cool.
3. Disconnect the rotisserie from the electrical power source.
4. Remove all detachable items such as spits, grease deflection trays, and grease collection unit. Drain grease from the drip pan and remove the drip pan from the oven when draining is complete.
5. Remove rotisserie drive assembly from the interior of the oven.
  - a. Supporting the central drive tube assembly, slide the metal washer and the collar on both sides of the drive tube toward the center of the tube to disengage.
  - b. Remove the disk drive wheels by pulling each directly toward the center of the oven compartment.
6. Wash all detached items separately in a ware washing area or sink. Do not use abrasive or corrosive cleaners. Only hot, soapy water is required for the optional Teflon® coated items.
7. Wipe the interior metal surfaces of the oven with a paper towel to remove loose food debris.
8. Clean interior with a damp cloth or sponge and any good commercial detergent at the recommended strength.
9. Spray heavily soiled areas with a water soluble degreaser and let stand for 10 minutes. After 10 minutes, remove soil with a plastic scouring pad.
10. Rinse surfaces thoroughly by wiping with sponge and clean, warm water
11. Remove excess water with sponge and wipe dry with a clean cloth or air dry. Leave door open until interior is completely dry. Always replace all removable parts including drip pan and grease deflection trays before operating.

## CAUTION



**METAL PARTS OF THIS EQUIPMENT BECOME EXTREMELY HOT WHEN IN OPERATION. TO AVOID BURNS, ALWAYS USE HAND PROTECTION WHEN OPERATING THIS APPLIANCE.**

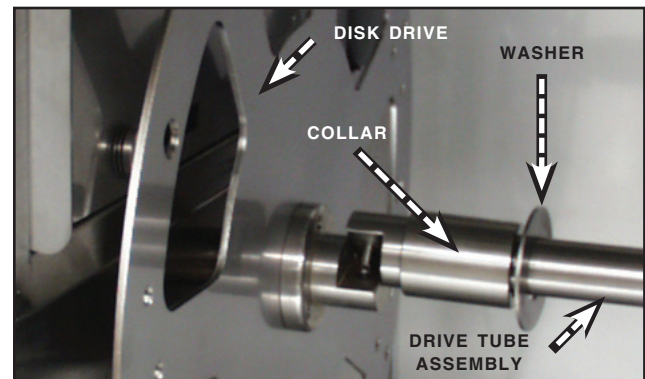

12. Interior can be wiped with a sanitizing solution after cleaning and rinsing. This solution must be approved for use on stainless steel food contact surfaces.
13. Wipe control panel and door handle(s) thoroughly since these areas harbor food debris and bacteria. Dry the control panel dry with a clean, soft cloth.
14. To help maintain the protective film coating on polished stainless steel, clean the exterior of the cabinet with a cleaner recommended for stainless steel surfaces. Spray the cleaning agent on a clean cloth and wipe with the grain of the stainless steel. For optional color coated exterior surfaces, wipe with a damp cloth or sponge and wipe dry with a clean cloth.
15. Clean glass doors with a standard, commercial glass cleaner.

## CAUTION



**Always follow appropriate state or local health (hygiene) regulations regarding all applicable cleaning and sanitation requirements for equipment.**

# CARE AND CLEANING

## DAILY ROTISSERIE GASKET CLEANING

It is important to prolong the life of the oven gasket by cleaning this item on a daily basis. The acids and related compounds found in fat, particularly chicken fat, will weaken the composition of the gasket unless cleaned on a daily basis.

Routine cleaning will help protect the composition of the gasket from deterioration caused by acidic foods. After allowing the oven to cool, remove pull-out gasket and wash in hot, soapy water. **Do not** place gasket in the dishwasher.

### CAUTION



**ALWAYS REPLACE THE DOOR GASKET BEFORE CLEANING THE INTERIOR OR OPERATING THE APPLIANCE.**



### DANGER



**DISCONNECT UNIT FROM POWER SOURCE BEFORE CLEANING OR SERVICING.**

## CLEAN ROTISSERIE CONVECTION BOX

Remove the screws holding the convection fan panel unto the inside of the cooking chamber. Using a commercial degreaser spray the back and front and allow the degreaser to soften the grease for 10 minutes. Using a plastic scouring pad, scrub any hard deposits and rinse with hot water.

Using a damp sponge and a plastic scouring pad if needed, wipe out any grease deposits that may be built up on the area surrounding the convection element and fan blade, taking care not to bend the element or the blade. A degreaser may be sprayed in this area to help dissolve any grease deposits that may be built up, but only a damp cloth or sponge can be used to remove the dissolved grease.

Reinstall fan panel and tighten screws finger tight.

**UNIT MAY BE RUN AFTER CLEANING FOR 30-40 MINUTES TO AID IN DRYING, ALTHOUGH THERE MAY BE SOME SMOKING, WHICH IS NORMAL.**

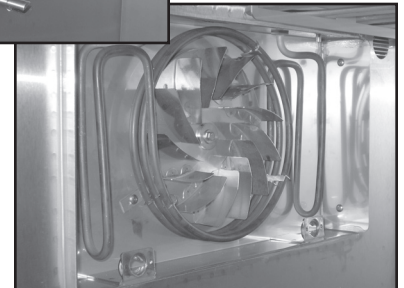

# CARE AND CLEANING

## CHECK OVERALL CONDITION OF THE ROTISSERIE ONCE A MONTH

Check for physical damage and loose screws. Correct any problems before they begin to interfere with the operation of the oven.

### DANGER



AT NO TIME SHOULD THE INTERIOR OR EXTERIOR BE STEAM CLEANED, HOSED DOWN, OR FLOODED WITH WATER OR LIQUID SOLUTION OF ANY KIND. DO NOT USE WATER JET TO CLEAN.



**SEVERE DAMAGE OR ELECTRICAL HAZARD COULD RESULT.**

WARRANTY BECOMES VOID IF APPLIANCE IS FLOODED



### CAUTION



TO PROTECT STAINLESS STEEL SURFACES, COMPLETELY AVOID THE USE OF ABRASIVE CLEANING COMPOUNDS, CHLORIDE BASED CLEANERS, OR CLEANERS CONTAINING QUATERNARY SALTS. NEVER USE HYDROCHLORIC ACID (MURIATIC ACID) ON STAINLESS STEEL. NEVER USE WIRE BRUSHES, METAL SCOURING PADS OR SCRAPERS.

## SERVICE



### DANGER



**LOCK-OUT OR POST BREAKER PANEL UNTIL SERVICE WORK HAS BEEN COMPLETED.**



### DANGER



**DISCONNECT UNIT FROM POWER SOURCE BEFORE CLEANING OR SERVICING.**

### CAUTION

THIS SECTION IS PROVIDED FOR THE ASSISTANCE OF QUALIFIED SERVICE TECHNICIANS ONLY AND IS NOT INTENDED FOR USE BY UNTRAINED OR UNAUTHORIZED SERVICE PERSONNEL.



### DANGER



**ELECTRICAL CONNECTIONS MUST BE MADE BY A QUALIFIED SERVICE TECHNICIAN IN ACCORDANCE WITH APPLICABLE ELECTRICAL CODES.**

## TROUBLESHOOTING GUIDE

Code	Description	Possible Cause
E-10	<b>Cavity air sensor shorted</b>	Cavity air sensor reading < 5°F. Verify sensor integrity. See sensor test instructions below.
E-11	<b>Cavity air sensor open</b>	Cavity air sensor reading > 517°F. Verify sensor integrity. See sensor test instructions below.
E-20	<b>Product probe is shorted</b> <i>Oven will cook in time only</i>	Product probe reading < 5°F. Verify sensor integrity. See sensor test instructions below.
E-21	<b>Product probe is open</b> <i>Oven will cook in time only</i>	Product Probe reading > 517°F. Verify sensor integrity. See sensor test instructions below.
E-30	<b>Under temperature</b>	Unit has not reached (set-point - 25°F) for more than 90 minutes.
E-31	<b>Over temperature</b>	Unit has been higher than 25°F above the maximum cavity set-point for more than 2 minutes. <b>Note:</b> Holding Cabinets with this error code are more than 145°F higher than the maximum set-point.
E-50	<b>Temp. measurement error</b>	Contact factory.
E-51	<b>Temp. measurement error</b>	Contact factory.
E-60	<b>Real time clock error</b>	Data set to factory default. Ensure that date and time are correct if applicable.
E-61	<b>Real time clock error</b>	Contact factory.
E-64	<b>Clock is not oscillating</b>	Contact factory.
E-70	<b>Configuration connector error (DIP switch)</b>	Refer to wiring diagram for the particular model and ensure dip switches on the control match the settings called out on the WD. If the dip switch settings are correct according to the print replace the control.
E-78	<b>Voltage low</b>	Voltage below 90 VAC on a 125 VAC unit, or below 190 VAC on a 208-240 VAC unit. Correct voltage.
E-79	<b>Voltage high</b>	Voltage over 135 VAC on a 125 VAC unit, or over 250 VAC on a 208-240 VAC unit. Correct voltage.
E-80	<b>EEPROM Error</b>	Ensure that all temperatures and times are properly set. Contact factory if problem persists.
E-81	<b>EEPROM Error</b>	Contact factory.
E-82	<b>EEPROM Error</b>	Contact factory.
E-83	<b>EEPROM Error</b>	Contact factory.
E-85	<b>EEPROM Error</b>	All timers, if previously on, are now off. Possible bad EEPROM.
E-86	<b>EEPROM Error</b>	Stored HACCP memory corrupted. HACCP Address reset to 1. Possible bad EEPROM. Contact factory if problem persists.
E-87	<b>EEPROM Error</b>	Stored offsets corrupted. Offsets reset to 0. Control may need a recalibration. Possible bad EEPROM. Contact factory if problem persists.
E-88	<b>EEPROM Error</b>	All timer set-points are reset to 1 minute. Timers, if previously on, are now off. Possible bad EEPROM.
E-90	<b>Button stuck</b>	A button has been held down for >60 seconds. Adjust control. Error will reset when the problem has been resolved.
E-dS	<b>Datakey error</b>	Datakey digital signature incompatible. Cycle power, and install compatible Datakey if error persists.
E-dT	<b>Datakey error</b>	Datakey incompatible with control. Install compatible Datakey.
E-dU	<b>Datakey unplugged</b>	Install Datakey and cycle power to control to clear error.
dLto	<b>Datalogger has timed out</b>	Cycle power. Contact factory if error persists.
dLSD	<b>Micro SD card not plugged in</b>	Plug in SD card and cycle power. Contact factory if error persists.

*Note: If in doubt, always cycle the power to the control and contact factory if the problem persists.*

### To test probe and air sensor:

Test probe and air sensor by placing sensor in ice water bath and using an ohmmeter set on the ohm scale. The reading should be 100 ohms resistance. If it is more than 2 ohms higher or lower, sensor needs to be replaced.

Part numbers and drawings are subject to change without notice.

# SERVICE

## VENTLESS HOOD, FINAL FLOOR (RIGHT HAND SHOWN)

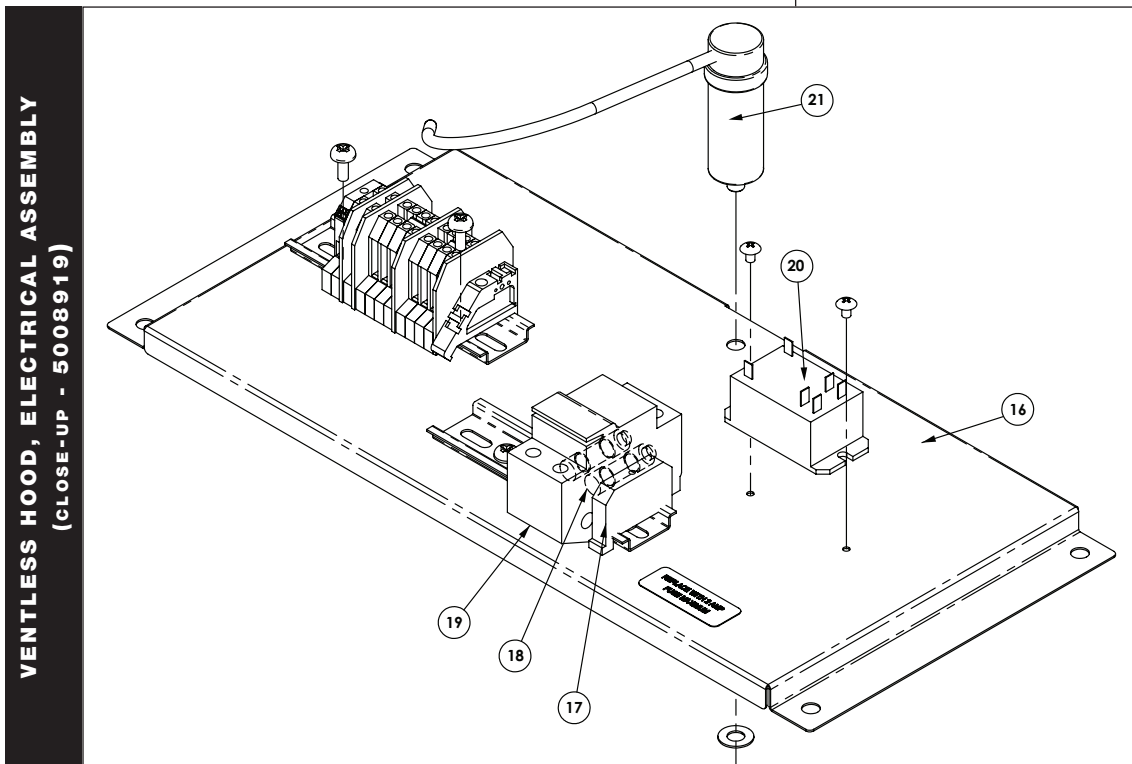
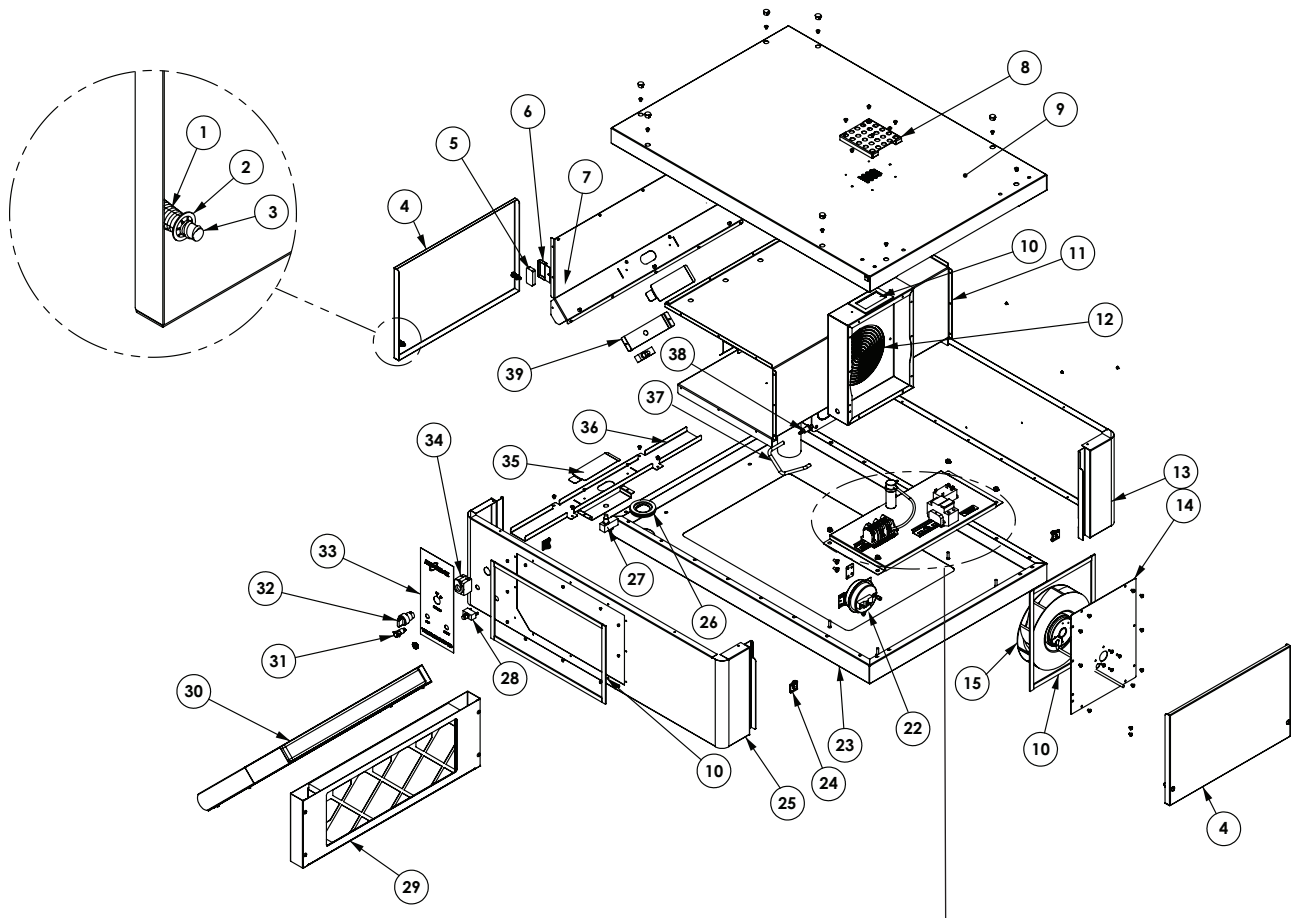

**VENTLESS HOOD, ELECTRICAL ASSEMBLY**  
(CLOSE-UP - 5008919)

Part numbers and drawings are subject to change without notice.

## VENTLESS HOOD, FINAL FLOOR & ELECTRICAL PARTS LIST

\*NOT SHOWN

ITEM	DESCRIPTION	PART NO.	QTY	
1	SPRING, M6 x 48, SAFETY	SD-22194	4	
2	WASHER, SAFETY, STEEL	WS-22195	4	
3	STUD, M6 x 27MM, 1/4 TURN	ST-22193	4	
4	COVER, SIDE	1007843	2	
5	MAGNET, SMCO, SILVER	MA-27568	1	
6	BRACKET, MAGNET, DOOR	1009532	1	
7	ASSEMBLY, SPOT, PANEL, WALL	RIGHT HAND 5009187	1	
		LEFT HAND*	5009510	1
8	HOUSING, DEFLECTOR, EXHAUST	1010387	1	
9	COVER, TOP	1007841	1	
10	TAPE, FOAM, 1/2" x 72YD	GS-2019	9	
11	WELDMENT, TUBE INNER	5007005	1	
12	SCREEN, FAN	1002412	1	
13	PANEL, NON-CONTROL SIDE	RIGHT HAND 1008460	1	
		LEFT HAND*	1010127	1
14	PLATE, COVER, FAN HOUSING	1009737	1	
15	FANS, 208-240V TANG	FA-3716	1	
16	ELECTRONIC COMPONENT ASSEMBLY	5008919	1	
17	TERMINAL	TN-34305	2	
18	FUSE, 2A CLASS G	FU-34929	2	
19	FUSE HOLDER, DUAL	FU-34771	1	
20	RELAY, POWER PANEL MOUNT	RL-33493	1	
21	FANS, CAPACITOR, 2MFD	FA-33440	1	
22	PRESSURE SWITCH KIT	5014332	1	
23	ASSEMBLY, WELD, PANEL, BOTTOM	RIGHT HAND 5009151	1	
		LEFT HAND*	5009504	1
24	CLIP, HOLDING, M6	CL-22196	4	
25	PANEL, CONTROL SIDE	RIGHT HAND 1008459	1	
		LEFT HAND*	1010132	1
26	BUSHING, SOCKET, MEMBRANE	BU-22204	1	
27	SWITCH, CT, SNAP ACTION, VHC'S	SW-33148	2	
28	SWITCH, PUSH BUTTON SPST	SW-33495	1	
29	FILTER ASSEMBLY, ODOR	FI-25866	1	
30	FILTER ASSEMBLY, GREASE	FI-25867	1	
31	WHITE PILOT LIGHT, 250V	LI-3951	1	
32	SWITCH, CT, POWER, MAIN, RED	SW-33101	1	
33	PANEL, OVERLAY, WHITE LOGO	PE-28690	1	
34	SWITCH, CT, PUSH BUTTON, INSERT	SW-3683	1	
35	FLAP, FILTER, VHML-5, VHES-5	1001478	2	
36	LOWER FILTER HOLDER	1009746	1	
37	TUBINGS, CT, NORPRENE	TU-24183	1	
38	FITTING, CT WITH HOSE BARB PANEL	FT-24182	1	
39	HOLDER, SWITCH	1009747	2	

Part numbers and drawings are subject to change without notice.

# SERVICE

## VENTLESS HOOD, FULL ASSEMBLY (RH, CURVED DOOR, PASS THROUGH SHOWN)

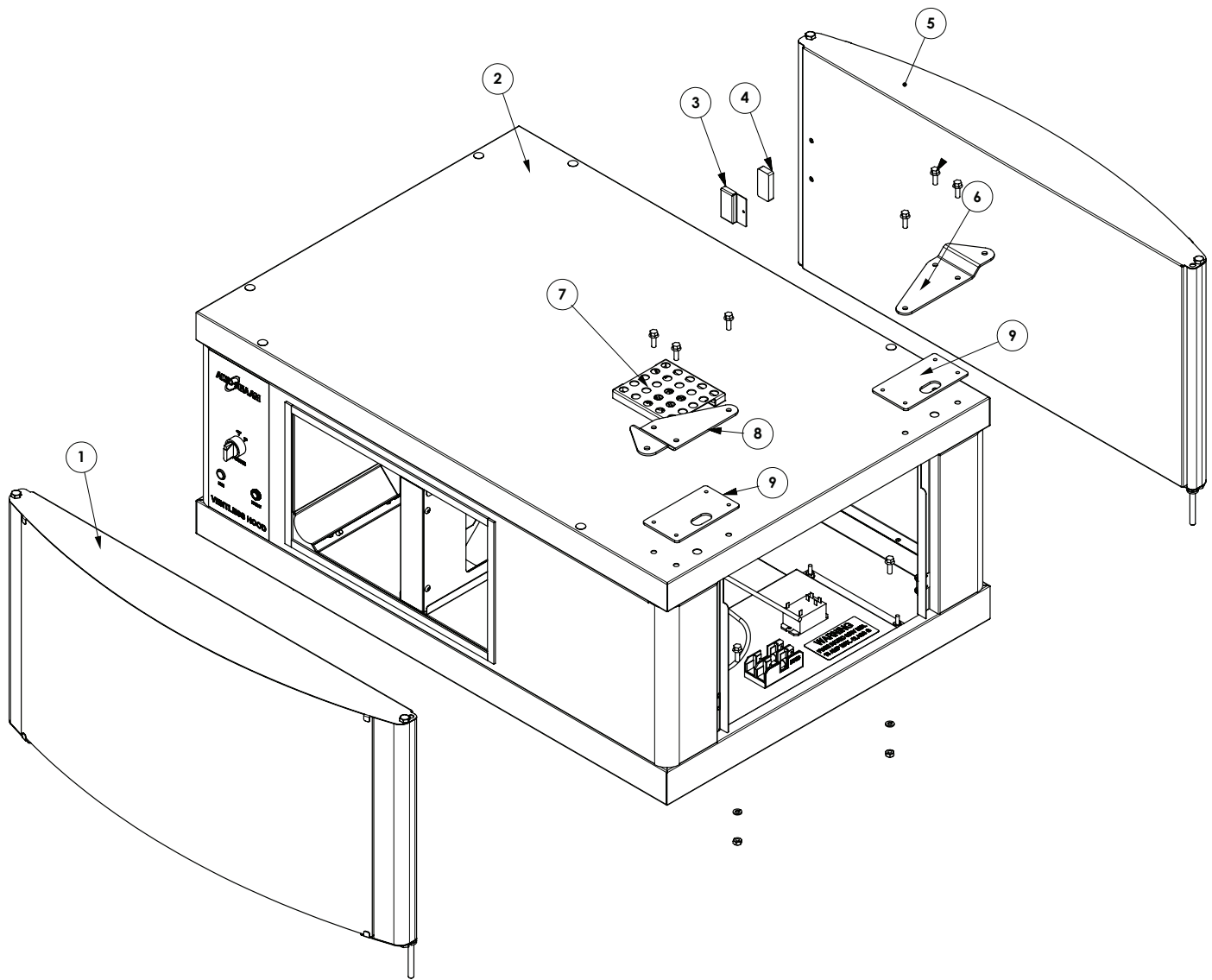

*NOT SHOWN		MODEL >	CURVED DOOR		FLAT DOOR*	
ITEM	DESCRIPTION	PART NO.	QTY	PART NO.	QTY	
1	DOOR ASSEMBLY, CONTROL SIDE	5007184	1	5007184	1	
2	COVER, TOP	1007841	1	1007841	1	
3	BRACKET, MAGNET, DOOR	1009532	1	1009532	1	
4	MAGNET, DOOR	MA-25734	1	MA-25734	1	
5	DOOR ASSEMBLY, NON-CONTROL SIDE	5009542	1	5009805	1	
6	HINGE, DOOR, REAR	1007758	1	1007758	1	
7	HOUSING, DEFLECTOR, EXHAUST	1010387	1	1010387	1	
8	HINGE, DOOR, FRONT	1007756	1	1007756	1	
9	PLATE, SUPPORT, DOOR	1008497	1	1008497	1	

Part numbers and drawings are subject to change without notice.



## ROTISSERIE, BULB REPLACEMENT INSTRUCTIONS

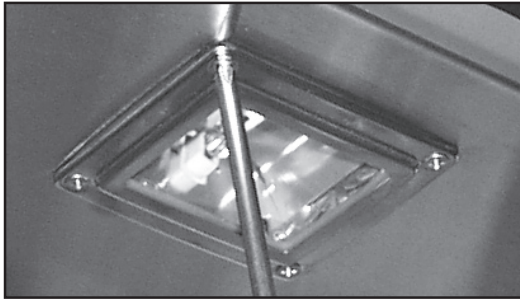

**A**

### To Replace Bulbs:

- A. Remove four screws holding glass light cover (CV-26607) and gasket (GS-26609) in place, taking care to not let the glass cover (GL-26608) fall into the oven.
- B. Pull bulb out.
- C. Push replacement bulb (LP-34213) in place.
- D. Re-install glass cover and gasket, securing with four screws removed in step one.

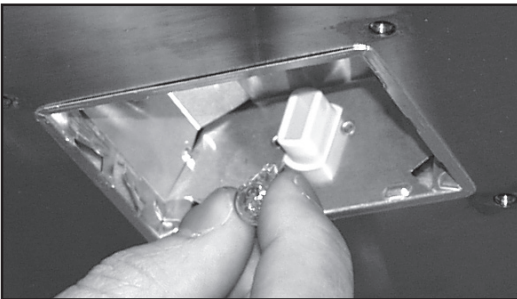

**B & C**

<b>CAUTION</b>	
	<p><b>DO NOT HANDLE NEW BULB WITH BARE HANDS. WHITE COTTON GLOVES SHOULD BE WORN WHEN REPLACING BULBS.</b></p>

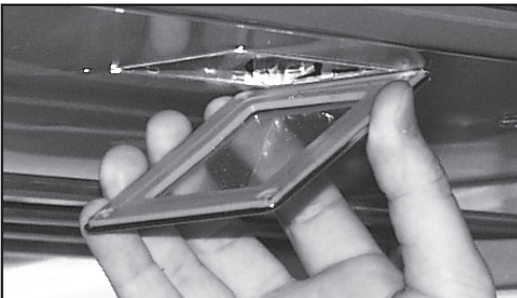

**D**

<b>CAUTION</b>	
	<p>The performance of this unit has been optimized using the factory provided bulbs. These bulbs should be replaced with an exact replacement or with a factory recommended replacement. These bulbs have been treated to resist breakage and must be replaced with similarly treated bulbs in order to maintain compliance with NSF standards. <b>DO NOT</b> over-tighten bulbs in their receptacles as this can cause damage to the bulb filament.</p>

# SERVICE

## ROTISSERIE, FINAL FLOOR (RIGHT HAND SHOWN)

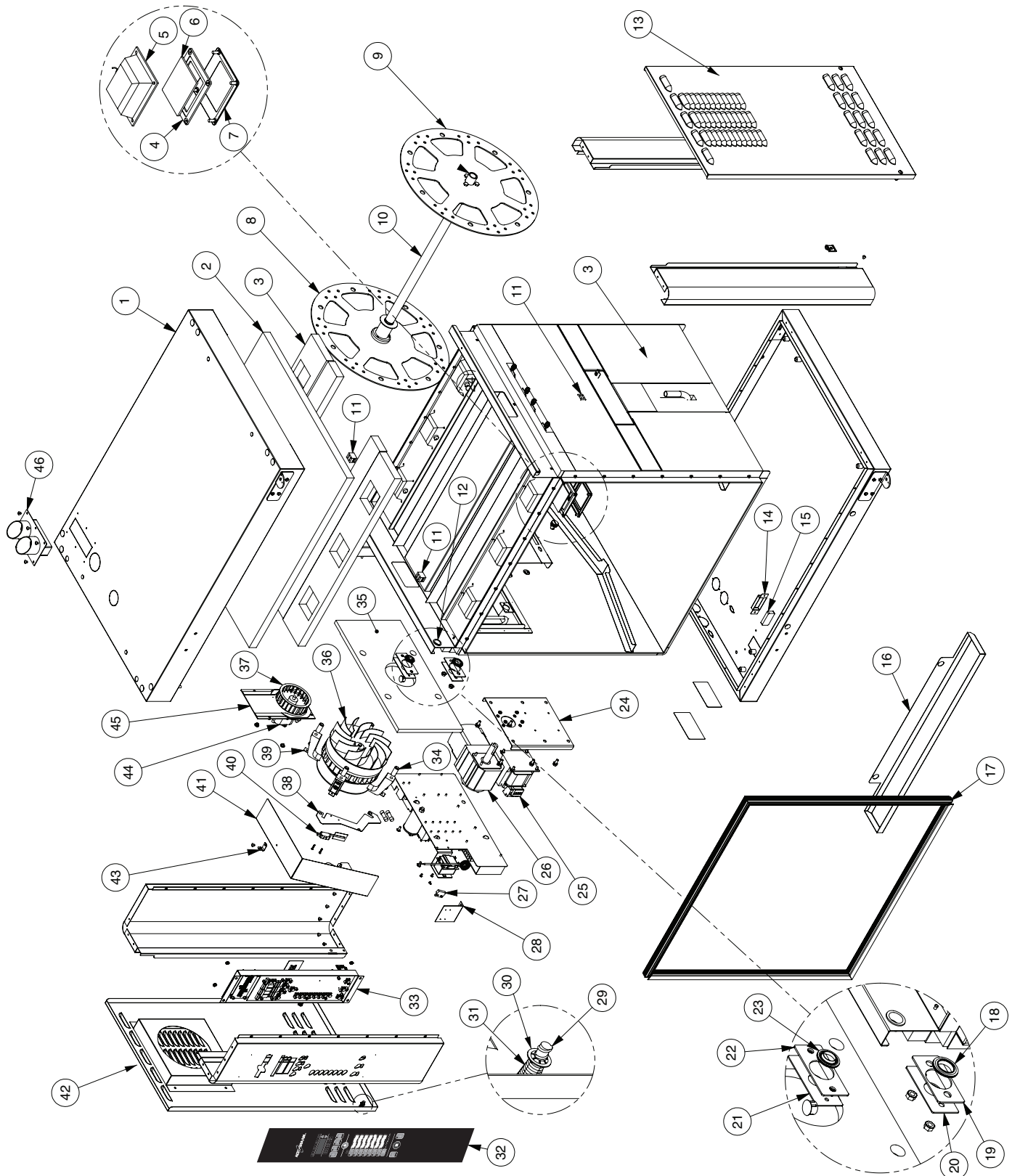

Part numbers and drawings are subject to change without notice.

## ROTISSERIE, FINAL FLOOR PARTS LIST

*NOT SHOWN		MODEL >	CURVED DOOR		FLAT DOOR	
ITEM	DESCRIPTION		PART NO.	QTY	PART NO.	QTY
1	SPOT ASSEMBLY, TOP PANEL		5009718	1	5009718	1
2	INSULATION, 1" X 4' X 25' #6, RT2300 (4.5 FT <sup>2</sup> )		IN-24588	1	IN-24588	1
3	INSULATION, NON-CONTROL SIDE		IN-28356	1	IN-28356	1
4	GASKET, OVEN LIGHT		GS-26609	6	GS-26609	6
5	LAMP ASSEMBLY, 20W		LP-34185	6	LP-34185	6
	REPLACEMENT BULBS		LP-34213	6	LP-34213	6
6	GLASS, OVEN LIGHT		GL-26608	6	GL-26608	6
7	COVER FOR OVEN LIGHT		CV-26607	6	CV-26607	6
8	DISC ASSEMBLY, CONTROL SIDE WITH PIN		5016037	1	5016037	1
9	DISC ASSEMBLY, NON-CONTROL SIDE		5016038	1	5016038	1
10	DRIVE, TUBE WELD, ASSEMBLY	STAINLESS STEEL	DV-26863	1	DV-26863	1
11	BLOCK, 2 TERMINAL, PORCELAIN		BK-33546	4	BK-33546	4
12	7/8" SNAP BUSHING, BLACK		BU-3007	4	BU-3007	4
13	PANEL, NON-CONTROL SIDE	STAINLESS STEEL	1001585	1	1001585	1
		BURGUNDY	1007425	1	1007425	1
14	COVER, MAGNET, INSIDE, SINGLE		1001667	4	1001667	4
15	MAGNET, SMCO, SILVER		MA-27568	4	MA-27568	4
16	DRIP TRAY, FRONT		1009063	1	1009063	1
17	GASKET, DOOR		GS-25753	1	GS-25753	1
18	BUSHING, SEAL, ROTISSERIE SHAFT		BU-27387	1	BU-27387	1
19	SHIM, SEAL, ROTISSERIE MOTOR		1007676	1	1007676	1
20	PLATE, COVER, SEAL, ROTISSERIE MOTOR		1006744	1	1006744	1
21	PLATE, COVER, SEAL, FAN MOTOR		1006783	1	1006783	1
22	SHIM, SEAL, FAN MOTOR		1007675	1	1007675	1
23	BUSHING, SEAL, FAN SHAFT		BU-27388	1	BU-27388	1
24	PLATE, MOUNTING, MOTOR		1007015	1	1007015	1

CONTINUED ON NEXT PAGE

### CAUTION

**THIS SECTION IS PROVIDED FOR THE ASSISTANCE OF QUALIFIED SERVICE TECHNICIANS ONLY AND IS NOT INTENDED FOR USE BY UNTRAINED OR UNAUTHORIZED SERVICE PERSONNEL.**

Part numbers and drawings are subject to change without notice.

# SERVICE

## ROTISSERIE, FINAL FLOOR PARTS LIST (CONTINUED)

*NOT SHOWN		MODEL >	CURVED DOOR		FLAT DOOR	
ITEM	DESCRIPTION		PART NO.	QTY	PART NO.	QTY
25	TRANSFORMER, STEP DOWN		TN-33460	1	TN-33460	1
26	MOTOR, AC, DRIVE, RIGHT ANGLE		MO-33893	1	MO-33893	1
	*MOTOR CAPACITOR		MO-33988	1	MO-33988	1
27	SWITCH, PROXIMITY SENSOR		SW-33906	1	SW-33906	1
28	BRACKET, DOOR SWITCH		1003474	1	1003474	1
29	STUD, CT M6 X 27MM, 1/4 TURN		ST-22193	1	ST-22193	1
30	WASHER, SAFETY, STEEL		WS-22195	4	WS-22195	4
31	SPRING, CT M6 X 48, SAFETY		SD-22194	1	SD-22194	1
32	PANEL, OVERLAY	DELUXE	PE-25738	1	PE-25738	1
		STANDARD	PE-25869	1	PE-25869	1
	INSERT CARD	DELUXE ONLY	PE-25740*	1	PE-25740*	1
33	ASSEMBLY, CONTROLS, ELECTRIC		CC-34453	1	CC-34453	1
34	SPACER, MOTOR ASSEMBLY		SP-26950	4	SP-26950	4
35	INSULATION, CONVECTION BOX		IN-27845	1	IN-27845	1
36	CONVECTION MOTOR ASSEMBLY		5002607	1	5002607	1
37	EXHAUST VENT MOTOR FAN WHEEL		FA-33481	1	FA-33481	1
38	BRACKET, BLOWER, SAIL SWITCH		1001913	1	1001913	1
39	BRACKET, MOUNTING, AIR DUCT		1002069	3	1002069	3
40	SWITCH, FAN, SAIL		SW-33907	1	SW-33907	1
41	AIR DUCT		1002068	1	1002068	1
42	PANEL, CONTROL SIDE	STAINLESS STEEL	5000949	1	5000949	1
		BURGUNDY	5006216	1	5006216	1
43	CLAMP, HIGH LIMIT		CM-2023	1	CM-2023	1
44	FAN, MOTOR, EXHAUST + VENT, 240V, 50/60HZ		FA-33221	1	FA-33221	1
45	ASSEMBLY, SPOT, PLATE, HOUSING		5009414	1	5009414	1
46	WELD ASSEMBLY, FAUX DUAL EXHAUST		5009743	1	5009743	1



Part numbers and drawings are subject to change without notice.

## ROTISSERIE, FULL ASSEMBLY (CURVED DOOR, FLAT BACK SHOWN)

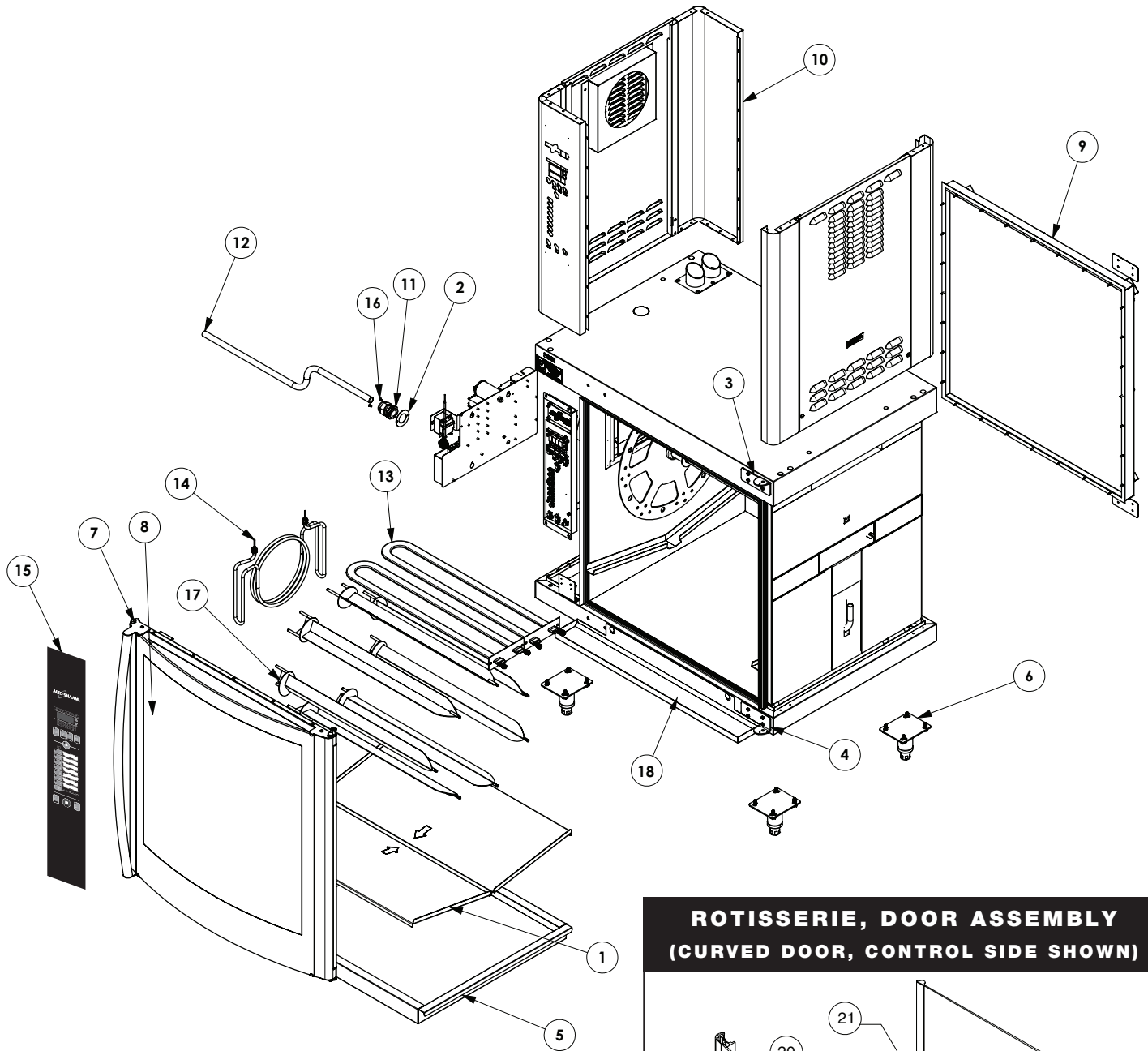

## ROTISSERIE, DOOR ASSEMBLY (CURVED DOOR, CONTROL SIDE SHOWN)

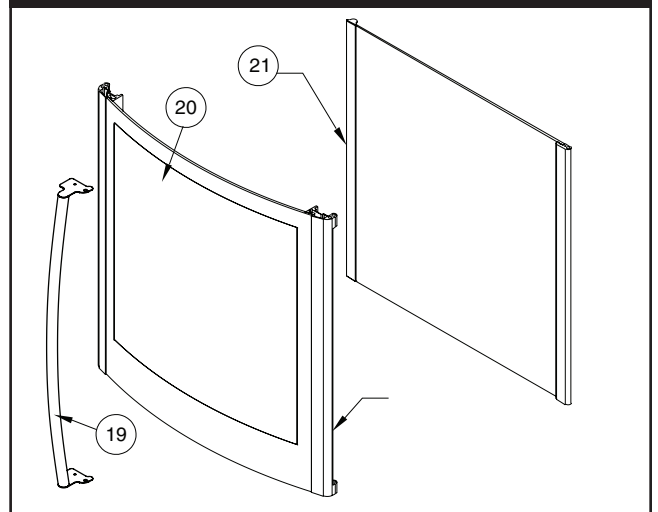

Part numbers and drawings are subject to change without notice.

# SERVICE

## ROTISSERIE, FULL ASSEMBLY PARTS LIST

*NOT SHOWN		MODEL >	CURVED DOOR		FLAT DOOR	
ITEM	DESCRIPTION		PART NO.	QTY	PART NO.	QTY
1	PAN, DRIP		1001555	2	1001555	2
2	WASHER, STRAIN RELIEF		1002389	1	1002389	1
3	HINGE, UPPER, DOOR		1007672	1	1002596	1
4	HINGE, LOWER, DOOR		1007673	1	1002597	1
5	ASSEMBLY WELD, DRIP PAN		5001094	1	5001094	1
6	ASSEMBLY, LEG, 4" (102mm), ADJUSTABLE - SET OF 4 (INCLUDES BELOW ITEMS)		5001765	1	5001765	1
	LEG PLATE		LG-26123	4	LG-26123	4
	FEET, S/S, INSERT, ADJUSTABLE		FE-26125	4	FE-26125	4
	MOUNTING SCREWS		SC-2351	16	SC-2351	16
7	ASSEMBLY, DOOR, CONTROL SIDE		5005773	1	5009591	1
	ASSEMBLY, DOOR, NON-CONTROL SIDE		5006426	1	5009815	1
8	OUTER GLASS DOOR		5007824	1	—	—
9	OPTION, SOLID BACK		5006214	1	5006214	1
10	ASSEMBLY, PANELS	STAINLESS STEEL (RIGHT-HAND)	5006461	1	5006461	1
		(LEFT-HAND)	5007085	1	5007085	1
		BURGUNDY (RIGHT-HAND)	5006211	1	5006211	1
		(LEFT-HAND)	5007086	1	5007086	1
		BLACK (RIGHT-HAND)	5006212	1	5006212	1
		(LEFT-HAND)	5009209	1	5009209	1
11	BUSHING, STRAIN RELIEF, INT	208-240V, 1PH	BU-33505	1	BU-33505	1
		208-240V, 3PH; 380-415V	BU-33948	1	BU-33948	1
12	CORD; 6-1/2' (1,981mm)	208-240V, 1PH	CD-33841	1	CD-33841	1
		208-240V, 3PH	CD-3987	1	CD-3987	1
13	ELEMENT, RADIANT, FIREBAR	208V	EL-33974	1	EL-33974	1
		230V; 240V; 380-415V	EL-33973	1	EL-33973	1
14	ELEMENT, 5kW, CONVECTION	208V	EL-34106	1	EL-34106	1
		230V; 240V; 380-415V	EL-34107	1	EL-34107	1
15	PANEL, OVERLAY	DELUXE	PE-25738	1	PE-25738	1
		STANDARD	PE-25869	1	PE-25869	1
	INSERT CARD	DELUXE ONLY	PE-25740*	1	PE-25740*	1
16	RIVET, BLIND, #44, S/S		RI-2100	2	RI-2100	2
17	WELDMENT, SPIT, ANGLED		SI-25934	7	SI-25934	7
18	DRIP TRAY, FRONT		1009063	1	1009063	1

## ROTISSERIE, DOOR ASSEMBLY PARTS LIST

		MODEL >	CURVED DOOR		FLAT DOOR	
ITEM	DESCRIPTION		PART NO.	QTY	PART NO.	QTY
19	HANDLE, DOOR		HD-26900	1	HD-26900	1
20	DOOR, OUTER GLASS		5007824	1	—	—
21	DOOR, INNER GLASS	CONTROL SIDE	5006779	1	—	—
		NON-CONTROL SIDE	5008322	1	—	—

### FASTENERS REQUIRED (NOT SHOWN)

DESCRIPTION	PART NO.	QTY	DESCRIPTION	PART NO.	QTY
WASHER, DOOR SPACE, BOTTOM	1002143	1	PIN, DOOR, BOTTOM	PI-26352	1
WASHER, FLAT, M8	WS-22298	1	NUT, HEX JAM 5/16-18	NU-25897	1
SCREW, 5/16-18 X 5/8	SC-2900	3	SCREW, INSERT	SC-25781	1
PIN, DOOR, TOP	PI-26350	1	SCREW, 8-32 X 3/8	SC-22378	6

Part numbers and drawings are subject to change without notice.

## ROTISSERIE, INTERIOR VIEW

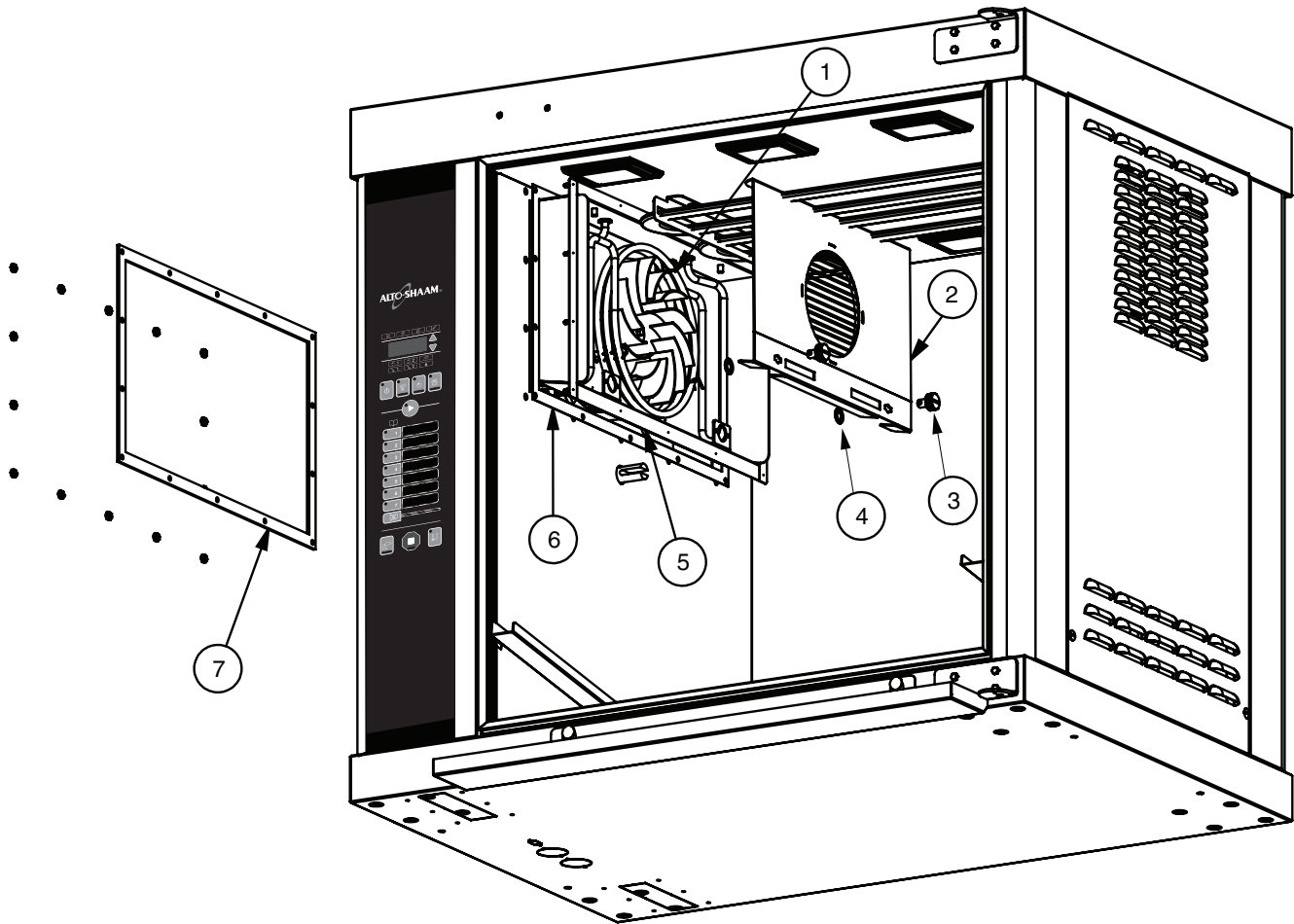

ITEM	DESCRIPTION	MODEL >		FLAT DOOR	
		CURVED DOOR		PART NO.	QTY
1	BRACKET, ELEMENT	1003595	1	1003595	1
2	WELDMENT, COVER, BLOWER	5005782	1	5005782	1
3	BLOWER COVER SCREW	CL-24089	2	CL-24089	2
4	BLOWER COVER SCREW LOCK WASHER	WS-24090	2	WS-24090	2
5	STUDWELD (SPOT) DUCT, BLOWER	5005848	1	5005848	1
6	GASKET, AIR BOX	GS-27389	1	GS-27389	1
7	PLATE, SUPPORT	1006650	1	1006650	1

Part numbers and drawings are subject to change without notice.

# SERVICE

## ROTISSERIE, ELECTRICAL SERVICE VIEW

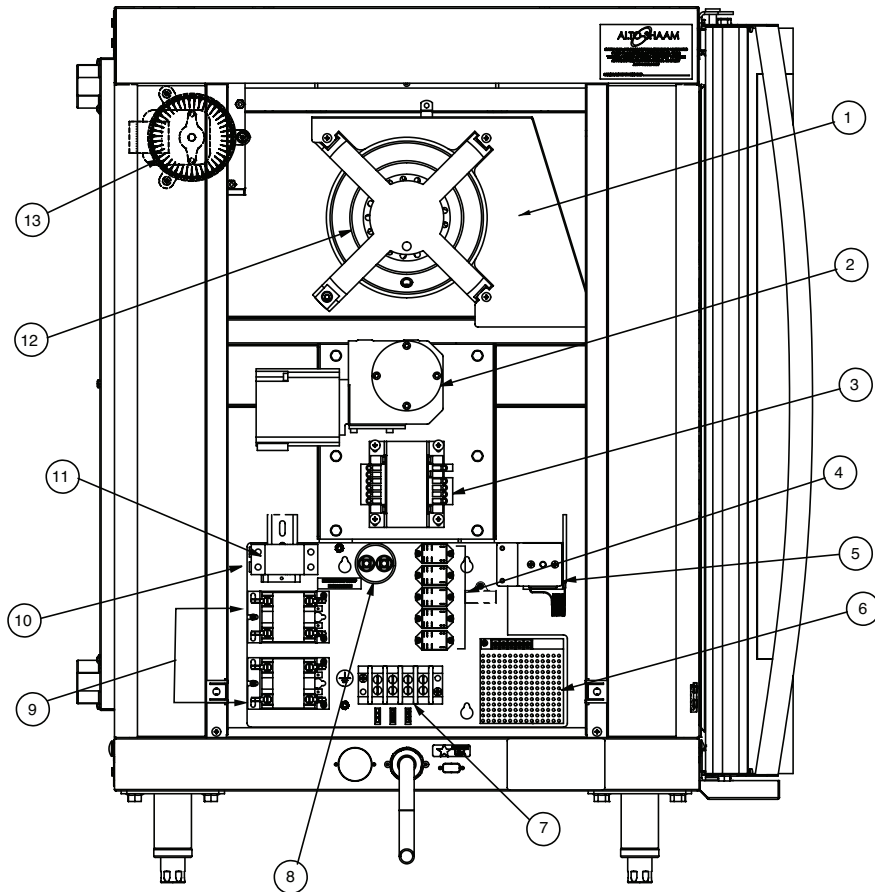

*NOT SHOWN		MODEL >	CURVED DOOR		FLAT DOOR	
ITEM	DESCRIPTION	PART NO.	QTY	PART NO.	QTY	
1	AIR DUCT	1002068	1	1002068	1	
2	MOTOR DRIVE, 230V, AC	MO-33893	1	MO-33893	1	
3	TRANSFORMER, STEP DOWN	TN-33460	1	TN-33460	1	
4	RELAY, POWER	RL-33930	5	RL-33930	5	
5	SWITCH, HIGH LIMIT	SW-34454	1	SW-34454	1	
6	BOARD, POWER SUPPLY, 12V DC, SWITCH	BA-33554	1	BA-33554	1	
7	TERMINAL BLOCK	BK-3023	1	BK-3023	1	
8	FAN, BLOWER MOTOR CAPACITOR, 4 UF	FA-33931	1	FA-33931	1	
9	CONTACTOR, 208/240V 3 POLE 25 AMP	CN-3052	2	CN-3052	2	
	RESISTOR, MOV, SURGE PROTECTOR	RS-3578*	2	RS-3578*	2	
10	FUSE, 15A, CLASS G	FU-34772	2	FU-34772	2	
11	FUSE HOLDER	FU-34771	1	FU-34771	1	
12	MOTOR, CONVECTION FAN, 220-240V	M0-33892	1	M0-33892	1	
13	EXHAUST VENT MOTOR FAN WHEEL, 240V, 50/60HZ	FA-33221	1	FA-33221	1	
14	SWITCH, FAN, SAIL	SW-33907*	1	SW-33907*	1	
15	DRIVE MOTOR CAPACITOR	MO-33988*	1	MO-33988*	1	

Part numbers and drawings are subject to change without notice.



## ROTISSERIE, REPLACEMENT OF GLASS DOOR (FLAT DOOR SHOWN)

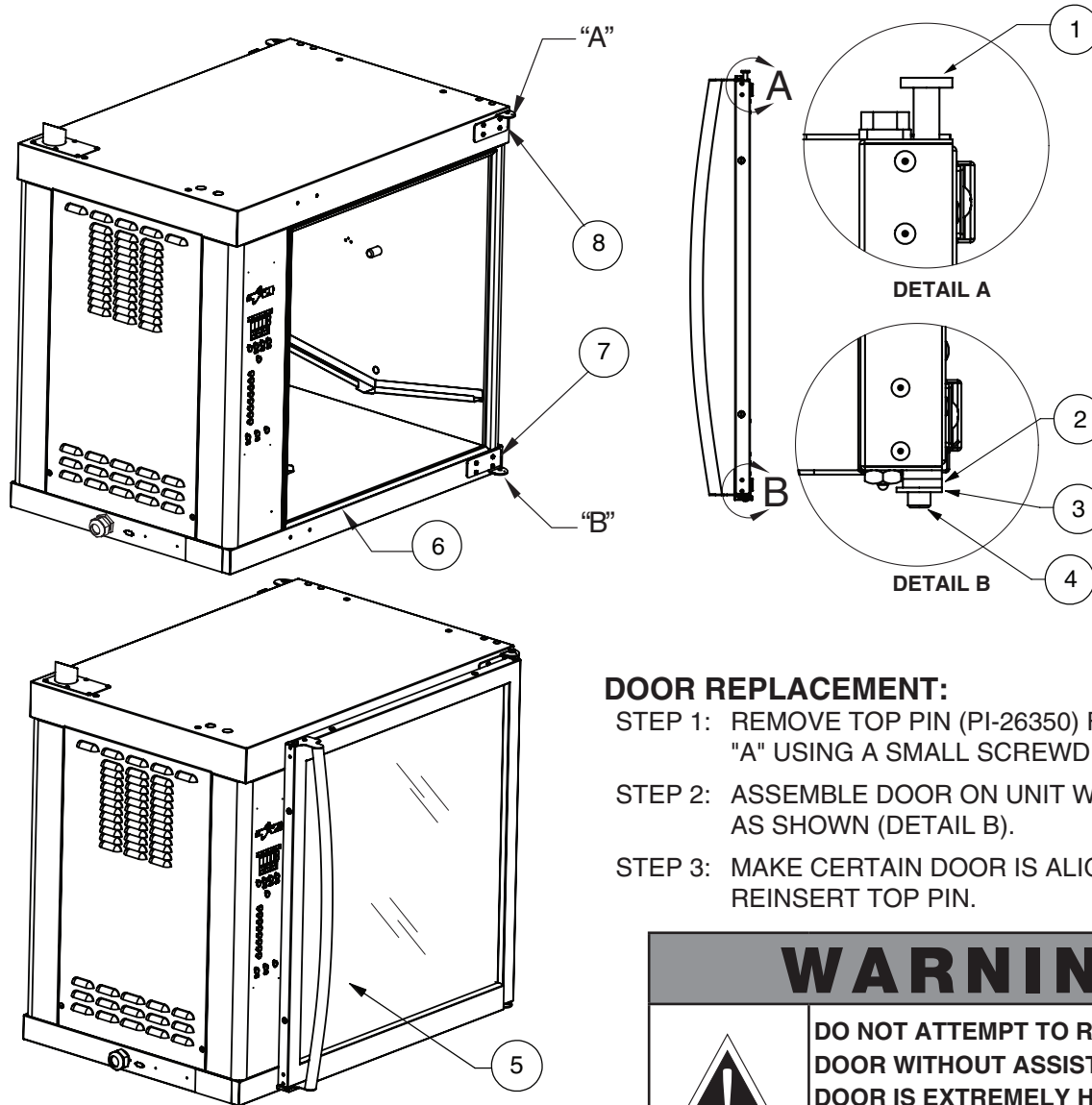

### DOOR REPLACEMENT:

- STEP 1: REMOVE TOP PIN (PI-26350) FROM BRACKET "A" USING A SMALL SCREWDRIVER.
- STEP 2: ASSEMBLE DOOR ON UNIT WITH SPACERS AS SHOWN (DETAIL B).
- STEP 3: MAKE CERTAIN DOOR IS ALIGNED AND REINSERT TOP PIN.

## WARNING



DO NOT ATTEMPT TO REMOVE THE DOOR WITHOUT ASSISTANCE. THE DOOR IS EXTREMELY HEAVY, WILL BE DAMAGED IF DROPPED, AND MAY CAUSE SERIOUS INJURY.

*NOT SHOWN		MODEL >	CURVED DOOR*		FLAT DOOR	
ITEM	DESCRIPTION	PART NO.	QTY	PART NO.	QTY	
1	PIN, DOOR, TOP	PI-26350	1	PI-26350	1	
2	SPACER	1002143	1	1002143	1	
3	WASHER	WS-22298	1	WS-22298	1	
4	PIN, DOOR, BOTTOM	PI-26352	1	PI-26352	1	
5	ASSEMBLY, DOOR, CONTROL SIDE	5006779	1	5009591	1	
	ASSEMBLY, DOOR, NON-CONTROL SIDE	5007824	1	5009815	1	
6	GASKET, DOOR	GS-25753	1	GS-25753	1	
7	HINGE, LOWER, DOOR	1007673	1	1007673	1	
8	HINGE, UPPER, DOOR	1007672	1	1007672	1	

Part numbers and drawings are subject to change without notice.

# SERVICE

## ROTISSERIE, STAINLESS STEEL BACK PANEL (5006214)

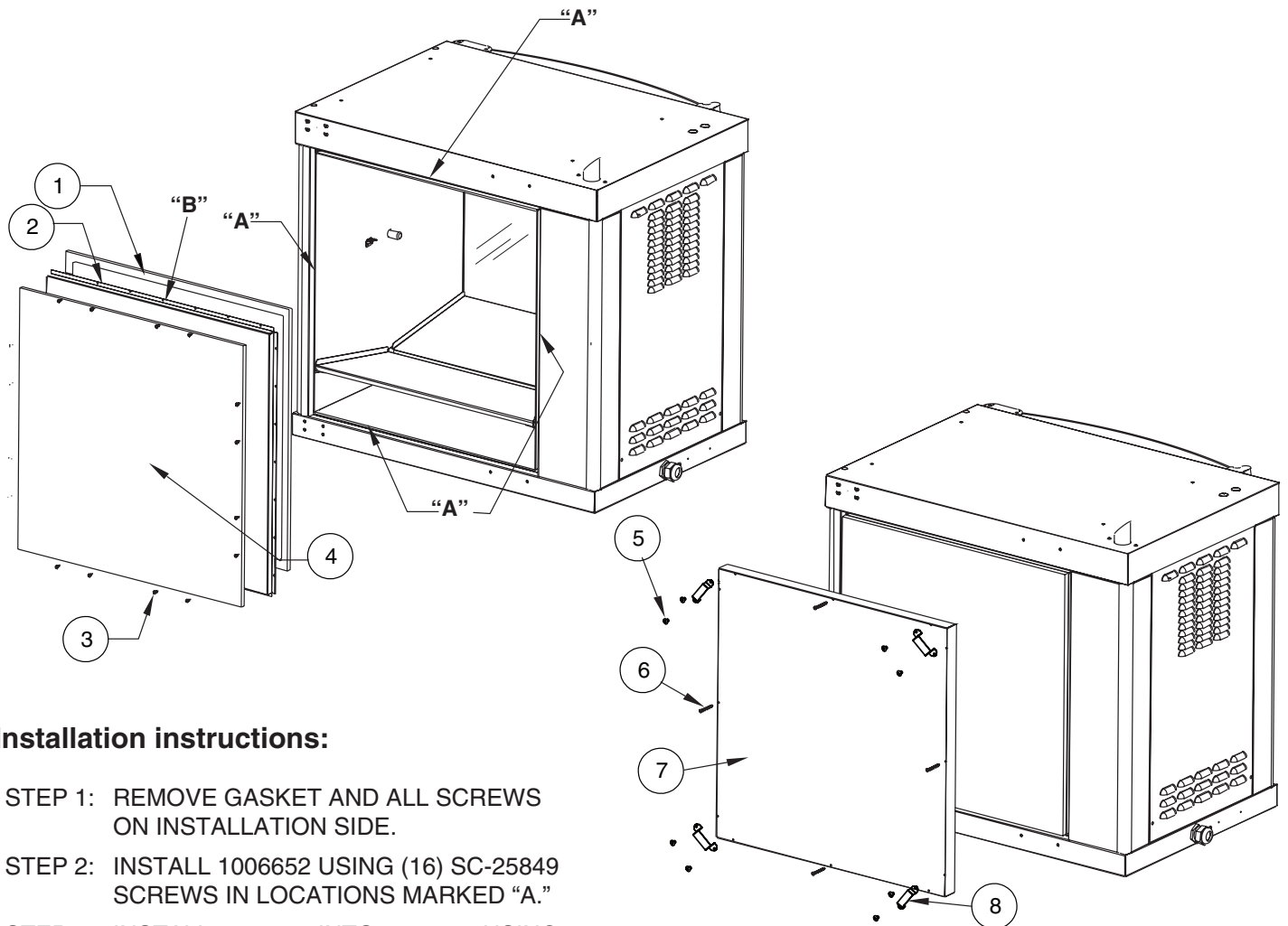

### Installation instructions:

- STEP 1: REMOVE GASKET AND ALL SCREWS ON INSTALLATION SIDE.
- STEP 2: INSTALL 1006652 USING (16) SC-25849 SCREWS IN LOCATIONS MARKED "A."
- STEP 3: INSTALL 1006746 INTO 1006652 USING (4) SC-27843 SCREWS, (8) SC-2459 SCREWS AND (4) 1002822 SPACERS.
- STEP 4: SEAL COMPLETE PERIMETER OF OPENING WITH SILICONE "B".

ITEM	DESCRIPTION	MODEL >		FLAT DOOR	
		CURVED DOOR	QTY	PART NO.	QTY
1	GASKET TAPE	GS-28123	1	GS-28123	1
2	PANEL, INTERIOR S/S BACK	1006652	1	1006652	1
3	SCREW, PAN HEAD	SC-25849	16	SC-25849	16
4	INSULATION, FIBERGLASS	IN-2003	1	IN-2003	1
5	SCREW, NC, PHILL TRUSS	SC-2459	8	SC-2459	8
6	SCREW, PAN HEAD, PHILLIPS	SC-27843	12	SC-27843	12
7	PANEL, EXTERIOR S/S BACK	1006746	1	1006746	1
8	SPACER, SOLID BACK	1002822	4	1002822	4

Part numbers and drawings are subject to change without notice.

## GREASE COLLECTION UNIT (5012271)

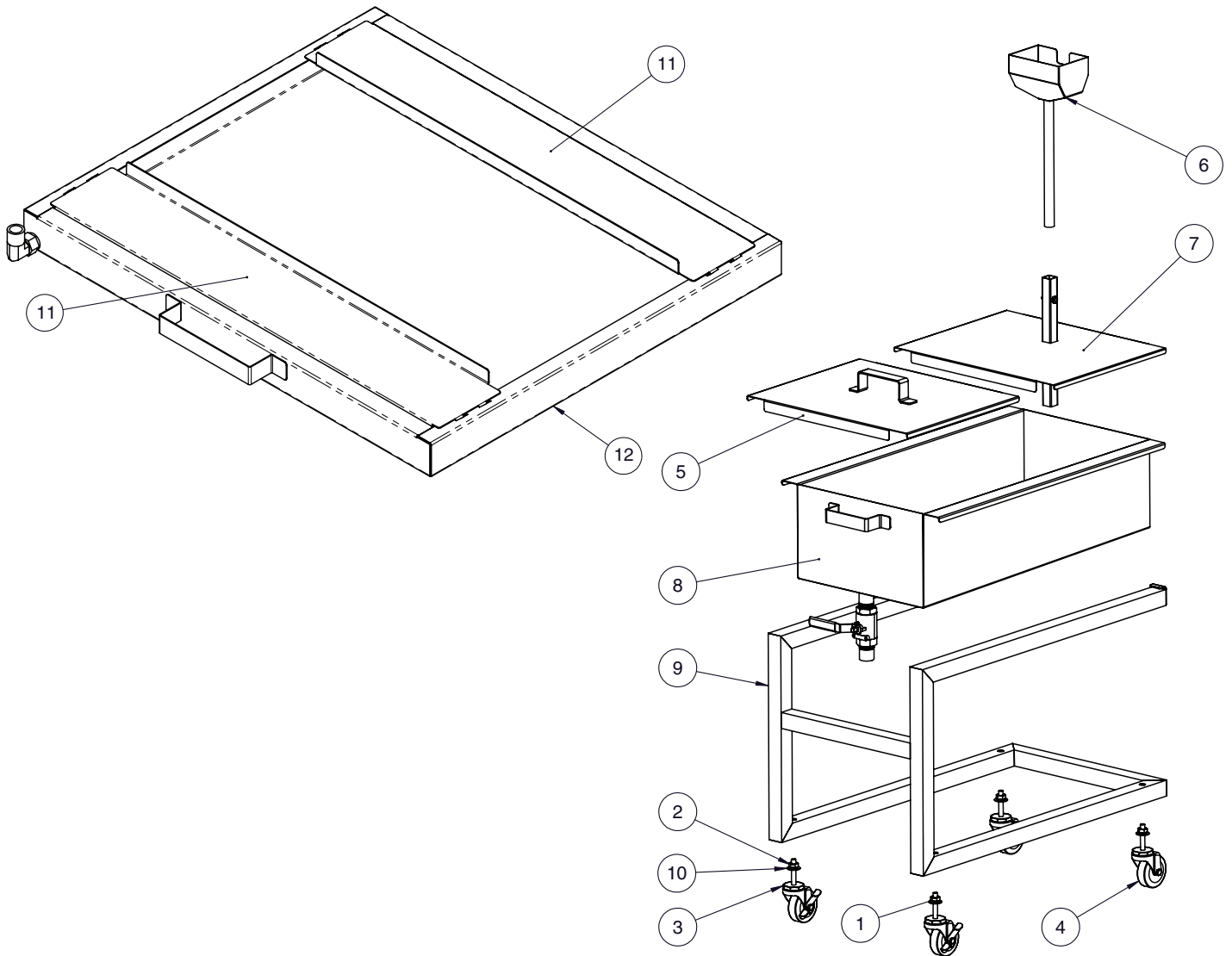

ITEM	DESCRIPTION	PART NO.	QTY
1	WASHER, LOCK, 1/2" DIA	WS-24893	4
2	NUT, 1/2-13 S/S JAMB	NU-24736	4
3	CASTER, STEM 3" SWIVEL, WITH BRAKE	CS-24857	2
4	CASTER, STEM 3" SWIVEL	CS-24858	2
5	COVER, SPACER	5012270	1
6	FUNNEL, TUBE	5012268	1
7	FUNNEL, COVER	5012266	1
8	GREASE PAN	5012265	1
9	FRAME WELDMENT	5012264	1
10	DIRECTIONAL PANEL SPACER	1006601	4
11	DRIP PAN COVER	1011621	2
12	ASSEMBLY WELD, DRIP PAN WITH DRAIN	5012290	1

Part numbers and drawings are subject to change without notice.

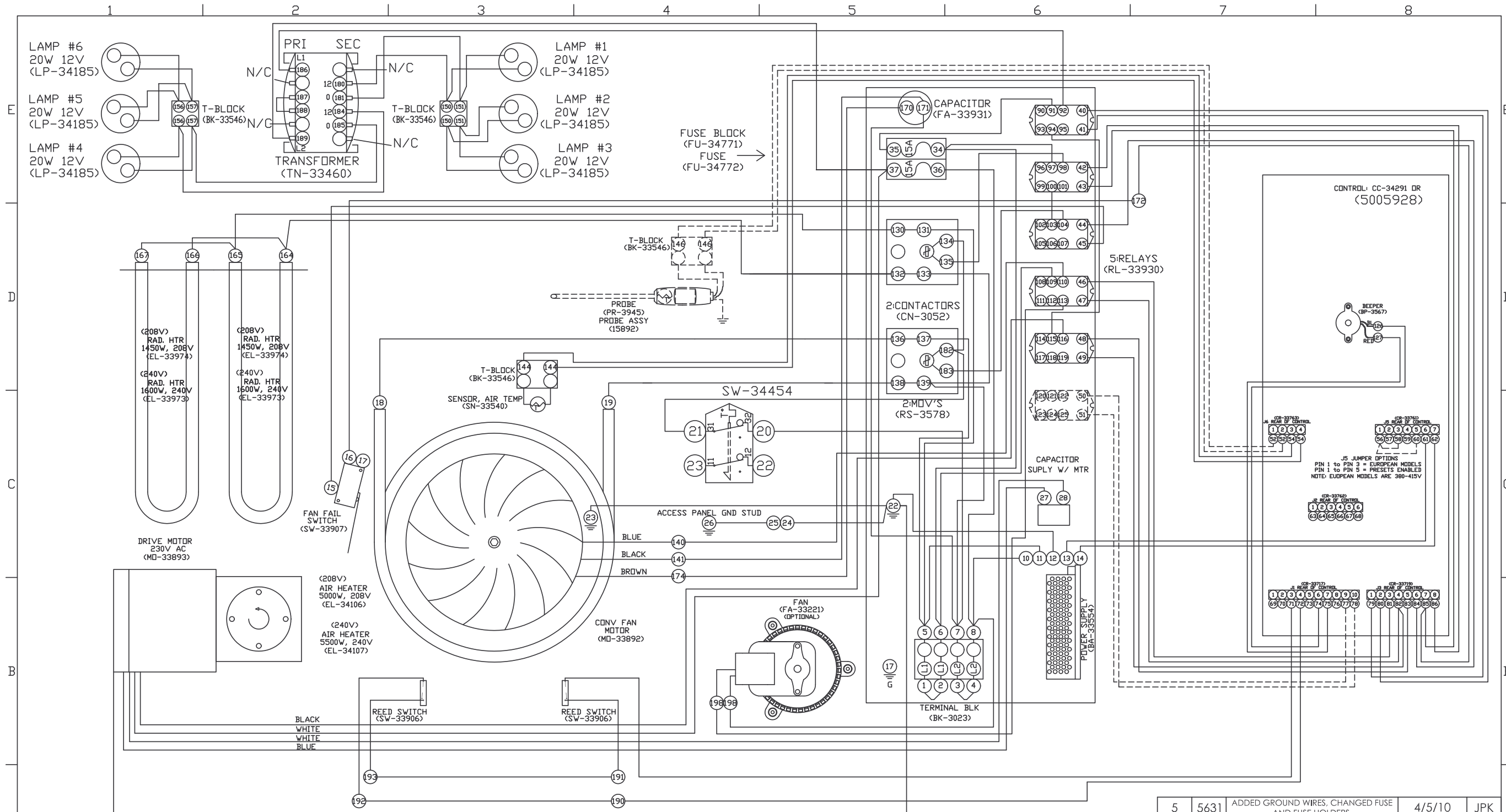

DESIGN	VOLTS	WATTS	AMPS
UL	208V	8300W	40A
DESIGN	240V	8800W	38A
UL	240V	8800W	38A

NOTE: SEE WIRE ASSEMBLY 5006891

5	5631	ADDED GROUND WIRES, CHANGED FUSE AND FUSE HOLDERS.	4/5/10	JPK
4	N/A	(50/60HZ) TO (60HZ)	9/24/09	KDS
3	5338	ADD FAN	1/13/09	JPK
REV	ECO	DESCRIPTION	DATE	APP
AR-7E(07) ELEC ROTIS 208-240V 1PH 60HZ				
<b>ALTO-SHAAM</b>		<b>WIRING DIAGRAM</b>		
BY: DDF DATE: 12/21/05		DWG: 7867	SHEET 1_OF_1	

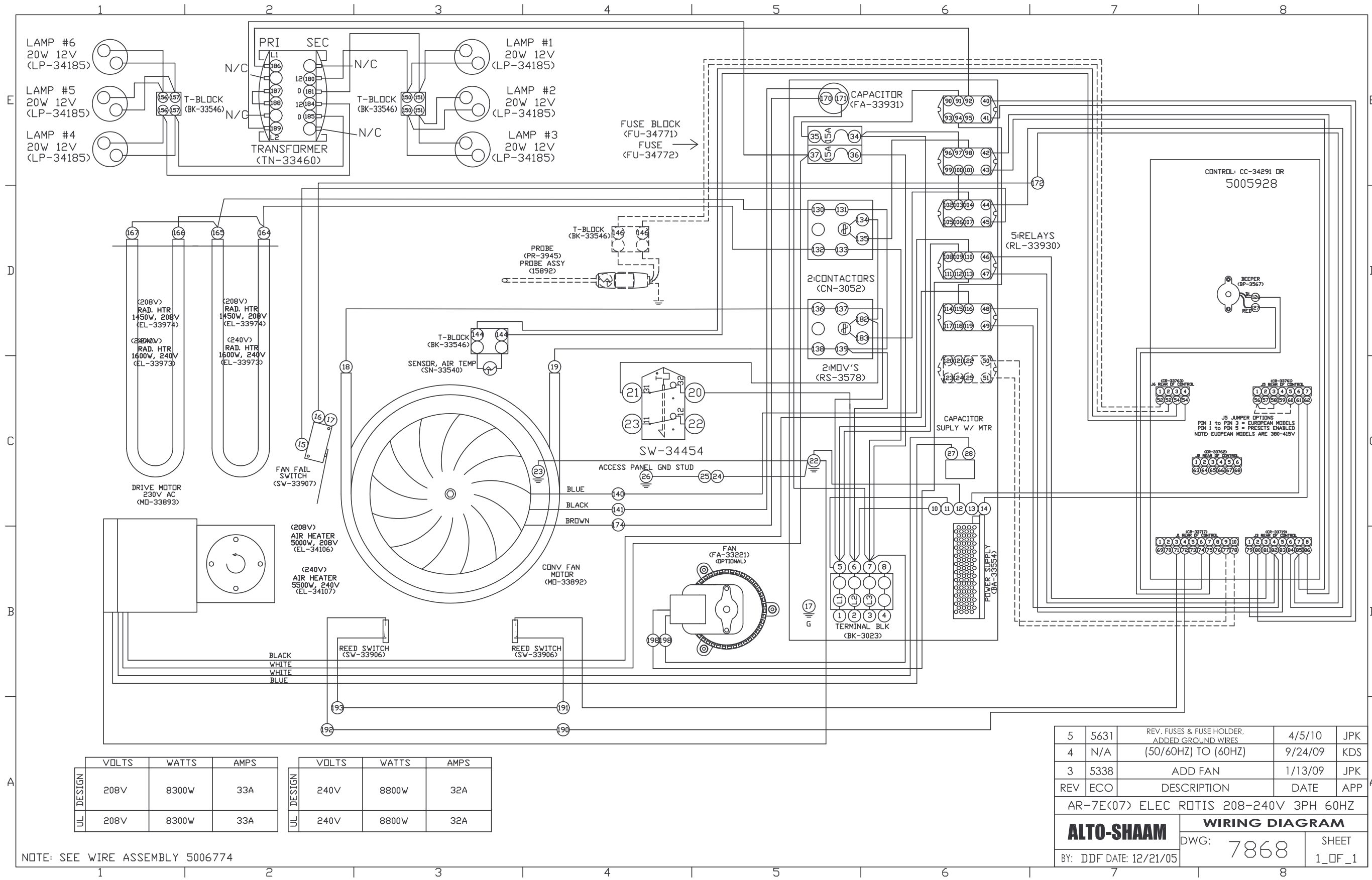

DESIGN	VOLTS	WATTS	AMPS
	208V	8300W	33A
UL	208V	8300W	33A

DESIGN	VOLTS	WATTS	AMPS
	240V	8800W	32A
UL	240V	8800W	32A

5	5631	REV. FUSES & FUSE HOLDER, ADDED GROUND WIRES (50/60HZ) TO (60HZ)	4/5/10	JPK
4	N/A		9/24/09	KDS
3	5338	ADD FAN	1/13/09	JPK
REV	ECO	DESCRIPTION	DATE	APP
AR-7E(07) ELEC ROTIS 208-240V 3PH 60HZ				
<b>ALTO-SHAAM</b>			<b>WIRING DIAGRAM</b>	
BY: DDF DATE: 12/21/05			DWG: 7868	SHEET 1_OF_1

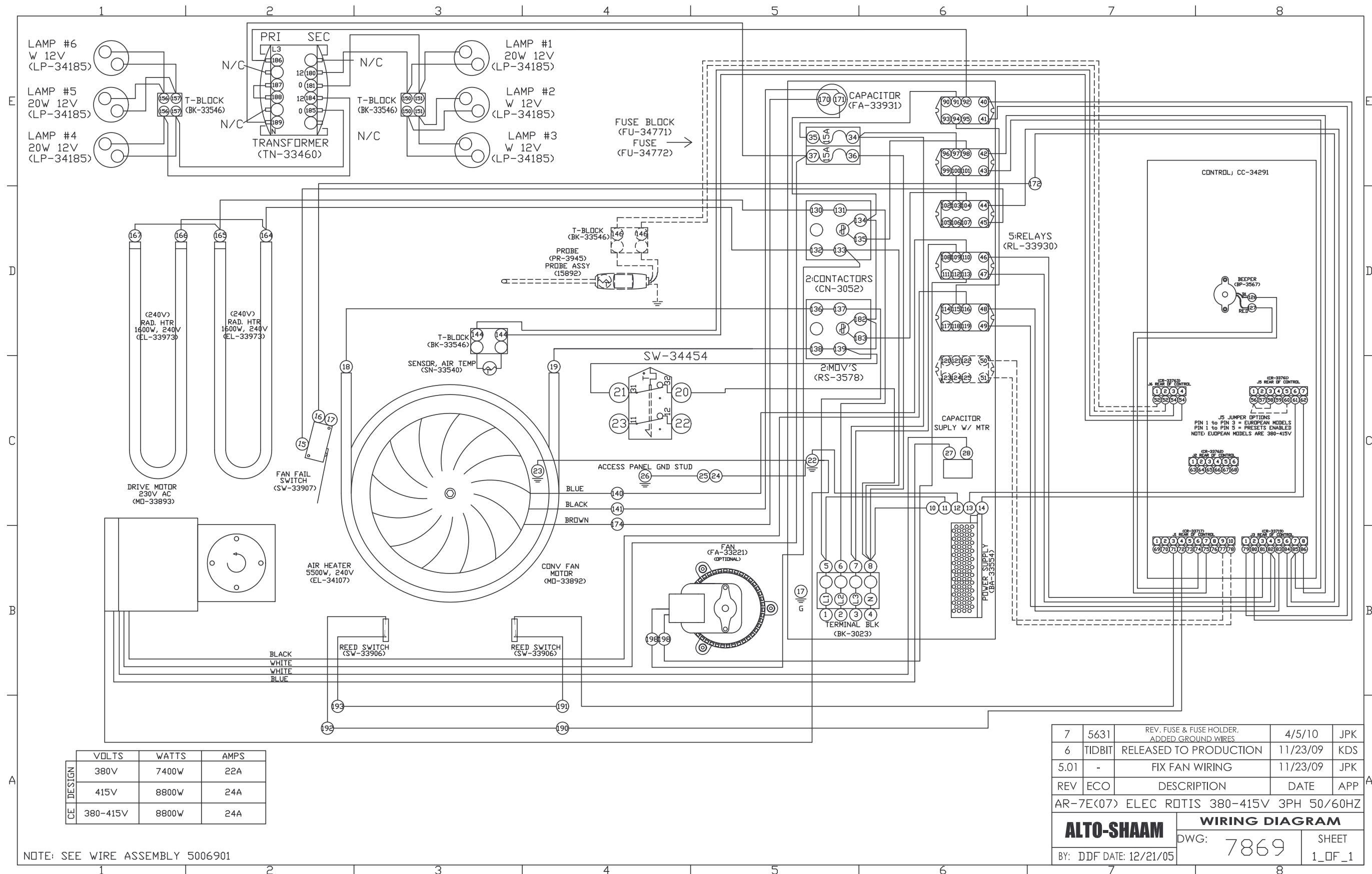

	VOLTS	WATTS	AMPS
CE DESIGN	380V	7400W	22A
	415V	8800W	24A
	380-415V	8800W	24A

7	5631	REV. FUSE & FUSE HOLDER, ADDED GROUND WIRES	4/5/10	JPK
6	TIDBIT	RELEASED TO PRODUCTION	11/23/09	KDS
5.01	-	FIX FAN WIRING	11/23/09	JPK
REV	ECO	DESCRIPTION	DATE	APP
AR-7E(07) ELEC ROTISSERIE 380-415V 3PH 50/60HZ				
<b>ALTO-SHAAM</b>		<b>WIRING DIAGRAM</b>		
BY: DDF	DATE: 12/21/05	DWG: 7869	SHEET 1_OF_1	

NOTE: SEE WIRE ASSEMBLY 5006901



# TRANSPORTATION DAMAGE and CLAIMS



All Alto-Shaam equipment is sold F.O.B. shipping point, and when accepted by the carrier, such shipments become the property of the consignee.

Should damage occur in shipment, it is a matter between the carrier and the consignee. In such cases, the carrier is assumed to be responsible for the safe delivery of the merchandise, unless negligence can be established on the part of the shipper.

1. Make an immediate inspection while the equipment is still in the truck or immediately after it is moved to the receiving area. Do not wait until after the material is moved to a storage area.
2. Do not sign a delivery receipt or a freight bill until you have made a proper count and inspection of all merchandise received.
3. Note all damage to packages directly on the carrier's delivery receipt.
4. Make certain the driver signs this receipt. If he refuses to sign, make a notation of this refusal on the receipt.
5. If the driver refuses to allow inspection, write the following on the delivery receipt:  
*Driver refuses to allow inspection of containers for visible damage.*
6. Telephone the carrier's office immediately upon finding damage, and request an inspection. Mail a written confirmation of the time, date, and the person called.
7. Save any packages and packing material for further inspection by the carrier.
8. Promptly file a written claim with the carrier and attach copies of all supporting paperwork.

We will continue our policy of assisting our customers in collecting claims which have been properly filed and actively pursued. We cannot, however, file any damage claims for you, assume the responsibility of any claims, or accept deductions in payment for such claims.

## LIMITED WARRANTY

Alto-Shaam, Inc. warrants to the original purchaser only that any original part that is found to be defective in material or workmanship will, at Alto-Shaam's option, subject to provisions hereinafter stated, be replaced with a new or rebuilt part.

### The original parts warranty period is as follows:

For the refrigeration compressor on Alto-Shaam Quickchillers™, five (5) years from the date of installation of appliance.

For the heating element on Halo Heat® cooking and holding ovens, as long as the original purchaser owns the oven. This excludes holding only equipment.

For all other original parts, one (1) year from the date of installation of appliance or fifteen (15) months from the shipping date, whichever occurs first.

The labor warranty period is one (1) year from the date of installation or fifteen (15) months from the shipping date, whichever occurs first.

Alto-Shaam will bear normal labor charges performed during standard business hours, excluding overtime, holiday rates or any additional fees.

To be valid, a warranty claim must be asserted during the applicable warranty period. This warranty is not transferable.

### THIS WARRANTY DOES NOT APPLY TO:

1. Calibration.
2. Replacement of light bulbs, door gaskets, and/or the replacement of glass due to damage of any kind.
3. Equipment damage caused by accident, shipping, improper installation or alteration.
4. Equipment used under conditions of abuse, misuse, carelessness or abnormal conditions, including but not limited to, equipment subjected to harsh or inappropriate chemicals, including but not limited to, compounds containing chloride or quaternary salts, poor water quality, or equipment with missing or altered serial numbers.
5. Damage incurred as a direct result of poor water quality, inadequate maintenance of steam generators and/or surfaces affected by water quality. Water quality and required maintenance of steam generating equipment is the responsibility of the owner/operator.
6. Damage caused by use of any cleaning agent other than Alto-Shaam's Combitherm® Cleaner, including but not limited to damage due to chlorine or other harmful chemicals. **Use of Alto-Shaam's Combitherm® Cleaner on Combitherm® ovens is highly recommended.**
7. Any losses or damage resulting from malfunction, including loss of product, food product, revenue, or consequential or incidental damages of any kind.
8. Equipment modified in any manner from original model, substitution of parts other than factory authorized parts, removal of any parts including legs, or addition of any parts.

This warranty is exclusive and is in lieu of all other warranties, express or implied, including the implied warranties of merchantability and fitness for a particular purpose. In no event shall Alto-Shaam be liable for loss of use, loss of revenue or profit, or loss of product, or for any indirect, special, incidental, or consequential damages. No person except an officer of Alto-Shaam, Inc. is authorized to modify this warranty or to incur on behalf of Alto-Shaam any other obligation or liability in connection with Alto-Shaam equipment.



Effective November 1, 2012

RECORD THE MODEL AND SERIAL NUMBER OF THE APPLIANCE FOR EASY REFERENCE.

ALWAYS REFER TO BOTH MODEL AND SERIAL NUMBER IN ANY CONTACT WITH ALTO-SHAAM REGARDING THIS APPLIANCE.

Model: \_\_\_\_\_ Date Installed: \_\_\_\_\_  
Voltage: \_\_\_\_\_ Purchased From: \_\_\_\_\_  
Serial Number: \_\_\_\_\_

W164 N9221 Water Street • P.O. Box 450 • Menomonee Falls, Wisconsin 53052-0450 • U.S.A.  
PHONE: 262.251.3800 • 800.558-8744 USA/CANADA FAX: 262.251.7067 • 800.329.8744 U.S.A. ONLY

www.alto-shaam.com

Download from Wwww.Somanuals.com. All Manuals Search And Download.

PRINTED IN U.S.A.



## Free Manuals Download Website

<http://myh66.com>

<http://usermanuals.us>

<http://www.somanuals.com>

<http://www.4manuals.cc>

<http://www.manual-lib.com>

<http://www.404manual.com>

<http://www.luxmanual.com>

<http://aubethermostatmanual.com>

Golf course search by state

<http://golfingnear.com>

Email search by domain

<http://emailbydomain.com>

Auto manuals search

<http://auto.somanuals.com>

TV manuals search

<http://tv.somanuals.com>