

PRODUCT INFORMATION

DF250SS



Suzuki 250SS

The DF250SS represents a new kind of Suzuki outboard—a “Sport 4-Stroke” designed for the sportsman who is serious about outboard performance. Based on a 4.0-liter Big Block V6 the DF250SS produces 250 horsepower and delivers outstanding acceleration throughout the entire powerband thanks to the incorporation of some of Suzuki’s most advanced technologies. With a 20-inch transom, it’s perfect for bass boats, sport pontoons, ski boats, flats and bay boats or any other boat that demands power, performance and reliability. The DF250SS also offers all the advantages of Suzuki’s 4-stroke technology, such as superior fuel economy, quiet, low vibration, and environmentally friendly operation, all while providing impressive performance and rock solid reliability.

If you’re as serious about outboard performance as you are about your sport, then the DF250SS is definitely for you.





DF250SS Main Features

- The DF250SS is designed to deliver performance and reliability that today's sport users demand.
- 4.0-liter Big Block V-6 engine—combined with Suzuki's Variable Valve Timing (VVT) and Multi Stage Induction delivers superior acceleration throughout the entire powerband.
- The 20-inch transom is perfect for bass boats, sport pontoon boats, ski boats, flats and bay boats or any boat that is designed for the sportsman who is serious about outboard performance.
- Gear case features a hydrodynamic design, introduced first on the flagship DF300, that reduces drag resistance for fast acceleration and increased top speed.
- The DF250SS complies with the California Air Resources Board's (CARB) 2008 exhaust emission standard and has earned the 3-Star Ultra Low Emission Rating.



Suzuki Technologies Deliver Outstanding Performance

VVT (Variable Valve Timing)

Suzuki engineers started off in a big way by designing the DF250SS based on a big block 4.0-liter engine, the largest displacement found in this class. This V6 engine features an aggressive cam profile, delivering maximum output and performance at high rpm, and Suzuki's advanced Variable Valve Timing (VVT), provides the DF250SS with the torque needed to boost low- to mid-range acceleration. VVT provides this boost by adjusting the intake valve timing, allowing intake valves to open before the exhaust valves are fully closed. This process creates a momentary overlap in the timing where both sets of valves are open. With VVT, this overlap can be increased or decreased by altering intake timing with the camshafts to optimize timing for low- and mid-range operation.

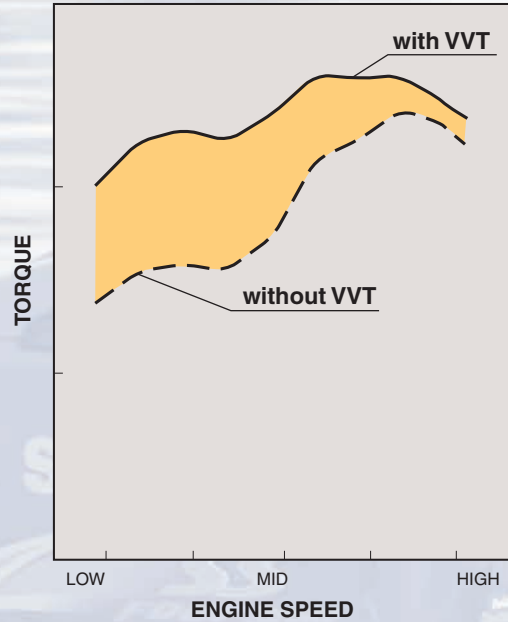
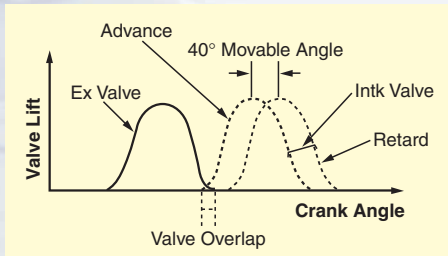
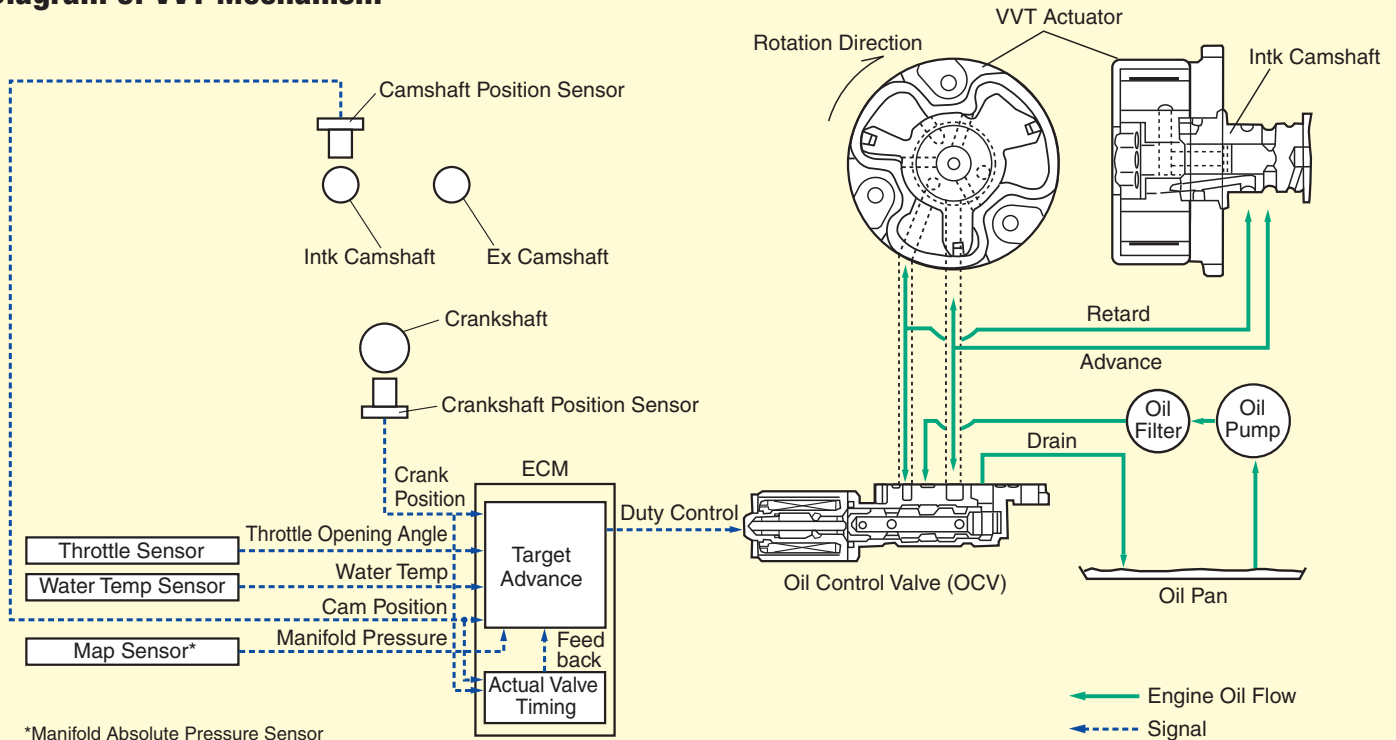

Diagram of VVT Mechanism



*Manifold Absolute Pressure Sensor

Multi-Stage Induction

Suzuki engineers also utilized Suzuki's Multi-Stage Induction, which changes intake manifold pipe length according to engine rpm to enhance engine performance. The DF250SS utilizes two intake manifold pipes per cylinder; one operates at low engine rpm and the other takes over at higher rpm. During low engine rpm, air enters the combustion chamber through the longer, curved manifold pipe. The particular length of this pipe allows just the right amount of fresh air into the chamber to improve combustion and boost low-end torque.

As engine rpm increases, a valve on the intake manifold opens, letting air enter directly

into the combustion chamber through the short, straight intake pipe. This allows a greater volume of air into the chamber, increasing the engine's ability to breathe at high rpm, thus improving high-end power output.

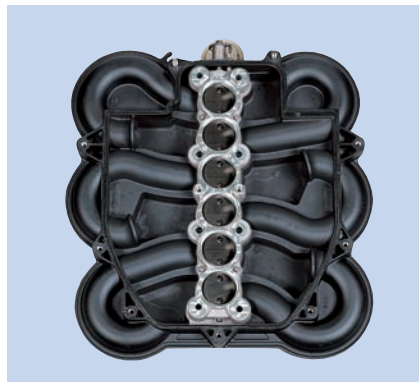

Multi-Stage Induction Module

Air Flow in Multi-Stage Induction Module

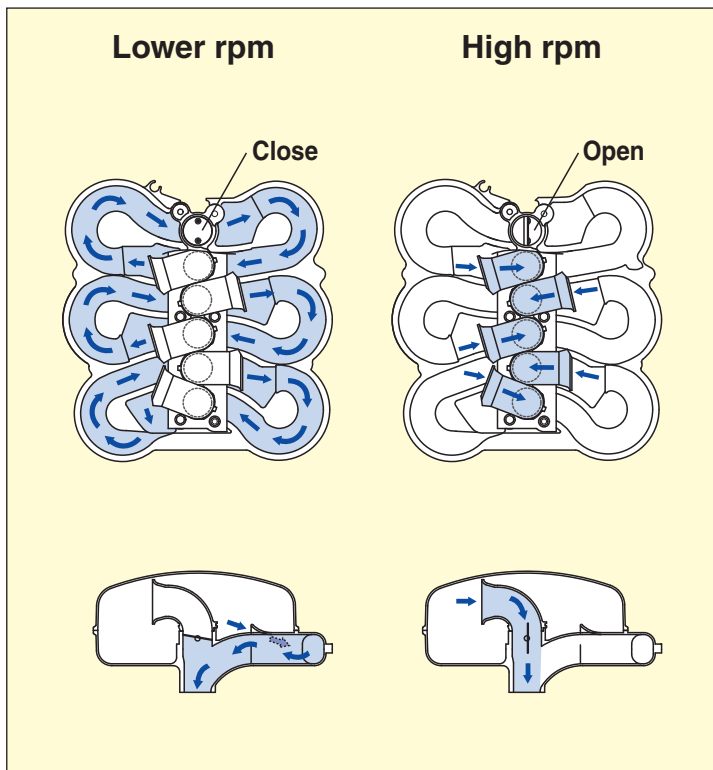

Torque Curve

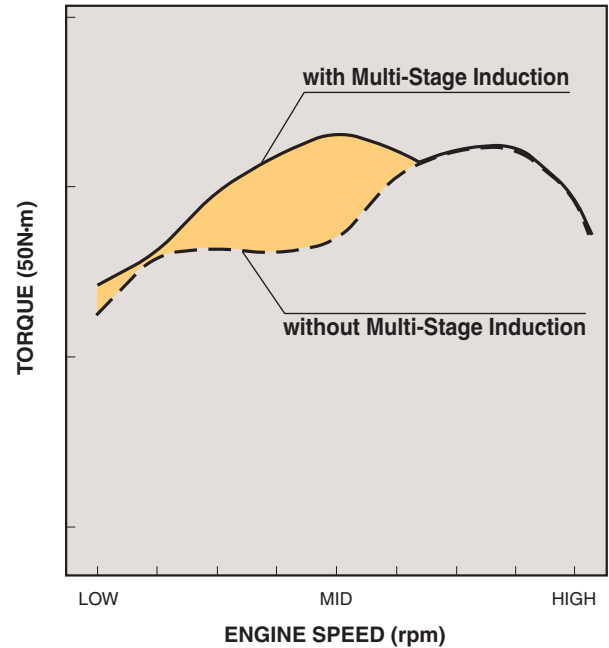

Forged Pistons

The upper portion of each piston used in the DF250SS is treated with an alumite coating that increases heat resistance. A resin coating applied to the piston skirt improves resistance to wear and reduces friction.

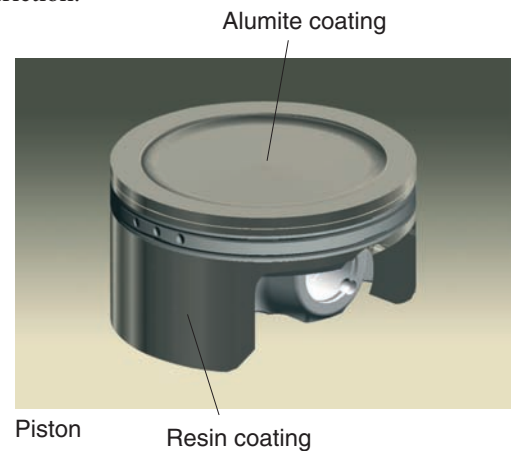

Fuel Cooler

The cooler the fuel the denser it is, and the denser it is, the more performance it delivers. The DF250SS incorporates a water-cooled fuel rail in the fuel delivery system. The fuel is cooled before it is injected into the cylinder resulting in better combustion and better performance.

Suzuki's Advanced Engineering Delivers Compact Designs

Offset Driveshaft

Suzuki incorporates a number of innovative designs into its outboards. As a result, Suzuki offers some of the most compact outboards in their class. One such design innovation is the offset driveshaft.

Positioning the crankshaft in front of the driveshaft, the outboard's center of gravity is moved forward. This contributes to the overall compact size and provides improved power and performance. It also greatly reduces engine vibration since the engine's axis of inertia, the point where vibrations are at a minimum, is in line with the upper engine mounts.

Offset Drive Shaft

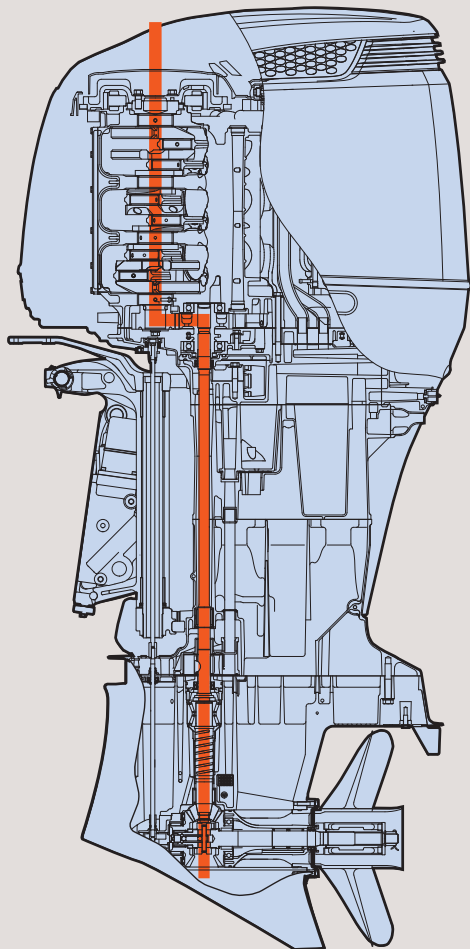

Two-Stage Cam Drive System

The DF250SS incorporates Suzuki's proven two-stage cam drive system that uses both gears and chain. The first stage gears transfer power between the crankshaft and the drive shaft. While the second stage transfers power from the drive shaft to the cam shafts with a chain. This system allows use of smaller diameter cam sprockets, which in turn allow for a reduction in valve angles also reducing the size of the cylinder head. Additionally, the timing chain system incorporates an automatic hydraulic tensioner to keep the chain properly adjusted and provide years of maintenance-free operation.



Streamlined Gear Case

The DF250SS takes advantage of the streamlined gear case introduced on the DF300 to reduce drag created as the lower unit moves through the water. This contributes to faster acceleration and increased speed.

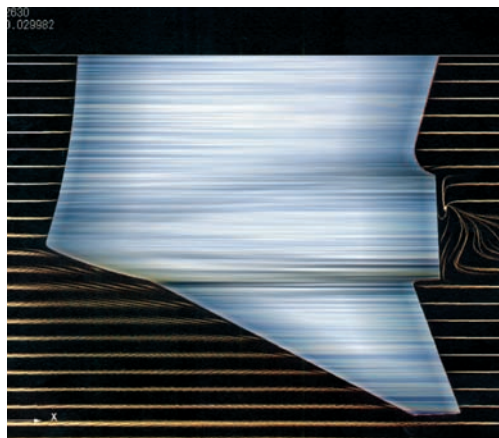

Guarding Against the Elements

Suzuki's Anti-Corrosion Finish

The outside of the DF250SS is covered with Suzuki's multi-layered anti-corrosion finish that is specially formulated to increase the durability of the engine and help protect the aluminum exterior that is constantly exposed to saltwater. This advanced finish offers maximum bonding of the finish to the outboard's aluminum surface, creating an effective treatment against corrosion.

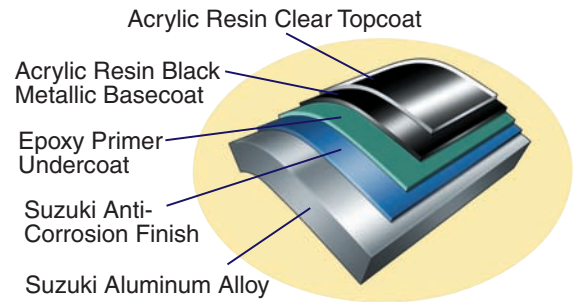

Large Air Intake, and Flywheel with Fan Blades

Increasing airflow into the engine can increase power output, so Suzuki engineers designed the DF250SS with dual air induction ports to maximize airflow into the engine to obtain maximum power output. The increased airflow delivers more low- to mid-range torque and provides the outboard with a wider powerband.

The flywheel is designed with fan blades that expel heat from within the engine cover and discharge the hot air out of the side of the cowl, keeping the temperature within the cowl under control.



Flywheel Magneto



Fuel Filter with Water Separator

The fuel system incorporates a large, easy to maintain fuel filter that removes contaminants from the fuel before they can reach the engine. A water separator built into the fuel filter offers a heightened level of protection by keeping water out of the engine.



Fuel Filter



Suzuki's Advanced Electronics Optimize Performance

32-Bit ECM and Suzuki's Multi Point Sequential Electronic Fuel Injection

Suzuki pioneered the use of multi point sequential electronic fuel injection in four-stroke outboards with the introduction of the DF60 and DF70—the first four-stroke outboards designed with multi point sequential electronic fuel injection. At the heart of the DF250SS is a multi point sequential fuel injection system which is operated by an ECM (Engine Control Module) using a series of engine sensors to constantly monitor crucial data, in real time. This comprehensive network of sensors includes the Manifold Absolute Pressure Sensor, Crankshaft Position Sensor, Intake Air Temperature Sensor, Cylinder Wall Temperature Sensor, Camshaft Position Sensor, and Exhaust Jacket Temperature Sensor. Using a powerful 32-bit computer, the ECM processes data from all of these sensors and instantly calculates the optimum amount of fuel to be injected at high pressure into each cylinder.

Benefits of this system include reduced exhaust emissions, which allow the DF250SS to comply with CARB 3-Star emission requirements, lower fuel consumption, smoother starts, crisper acceleration, impressive performance, and maximum efficiency.



Direct Ignition System

Supplying spark to the DF250SS is an advanced ignition system that utilizes integral type spark plug caps with built-in ignition coils. The system is controlled by the outboard's powerful 32-bit computer and provides each cylinder with optimum spark timing. In addition to reducing the number of parts and simplifying the wiring system, this arrangement greatly reduces electronic engine "noise" that can interfere with VHF radios, fish finders, and other marine electronics.



Regulator with Dual Circuit Charging System

The DF250SS features a built in dual circuit charging system that can be adapted* for use with dual-battery configurations. When used in this configuration, the system charges both main and auxiliary batteries simultaneously on independent circuits. With this design, you can drain down the accessory battery powering your electronics and still have a fully charged main battery for starting the motor.

* Requires purchase of optional wiring harness.

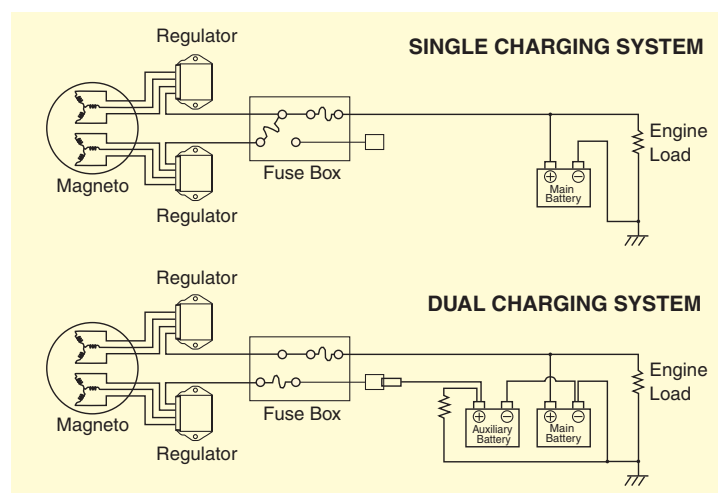

High Output Alternator

The DF250SS generates electricity from a high output alternator that delivers 54A (12V) of electrical power. Suzuki's design allows the alternator to produce a majority of its output at low rpm, so even when operating at 1000rpm it can produce approximately 38A of power. In most situations, this is enough power to keep an assortment of electronics up and running.

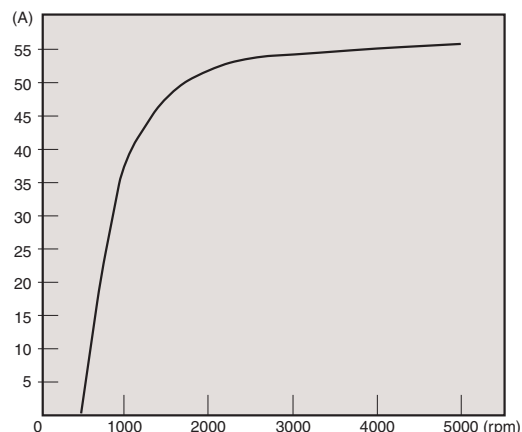

Features that Offer Convenient Operation

Tilt Limit Switch

The outboard tilt system incorporates an adjustable tilt limit switch, which prevents the motor from tilting beyond a predetermined position. This can be used to protect both the boat and motor from damage that can occur when tilting the motor.

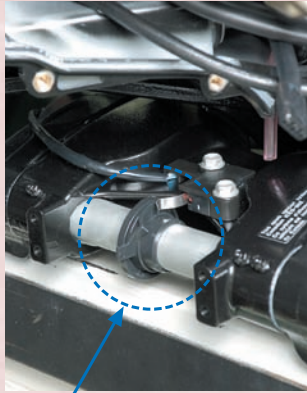

Tilt Limit System

Dual Engine Flush Ports

The buildup of sand and salt in the engine's cooling system can lead to engine damage. To aid in reducing such buildup, the DF250SS is designed with two freshwater flush ports that make flushing of the cooling system as convenient and easy as possible. With one port located on the rear panel and the second on the front panel, access is easy and flushing out the system is possible whether the boat is in the water or on the trailer.



Genuine Suzuki Parts and Accessories

Genuine Suzuki Parts and Accessories are your key to total performance and boating satisfaction. Suzuki controls and gauges give boaters the power and information they need to master any day on the water. We offer a full line of premium quality stainless steel props specifically engineered to maximize the performance and fuel efficiency of Suzuki 4-stroke outboards. And you can rely on genuine Suzuki fuel and oil filters, engine oil and gear oil. Suzuki Marine 4 Cycle Engine Oil offers your outboard the Ultimate in performance and protection. Our engine oil meets the advanced NMMA FC-W certification, providing superior lubrication and the industries most complete panel of anti-corrosion additives and rust inhibitors.. The Suzuki Modular Instrument System uses an easy to connect and expandable cable system to transmit graphic and numerical data to Multi-Function gauges. Easy to set up and install, these SMIS Multi-Function Gauges display real-time readings that monitor all engine functions. These gauges are also NMEA 2000 compatible, and with the simple push of a few buttons, access to a wealth of vital data is right at your fingertips. Here at Suzuki Marine, we have what you need to keep your Suzuki outboard running strong season after season.





DF250SS SPECIFICATIONS

MODEL	DF250SS	
ENGINE TYPE	4-Stroke DOHC 24 Valve	
FUEL DELIVERY SYSTEM	Multi Point Sequential Electronic Fuel Injection	
TRANSOM HEIGHT mm (in.)	508mm / 20 in.	
STARTING SYSTEM	Electric	
WEIGHT kg (lbs.)*	262kg / 578lbs	
NO. OF CYLINDERS	V6 (55-degree)	
PISTON DISPLACEMENT cm ³ (cu.in.)	4,028 (245.6)	
BORE x STROKE mm (in.)	98 x 89 (3.81 x 3.46)	
MAXIMUM OUTPUT kW	184kw / 250 hp	
FULL THROTTLE OPERATING RANGE rpm	5300-6300	
STEERING	Remote	
OIL PAN CAPACITY I (U.S. / Imp. qt.)	8.0 L / 8.5 U.S. qt. / 7.0 Imp qt.	
IGNITION SYSTEM	Fully-transistorized	
ALTERNATOR	12V 54A	
ENGINE MOUNTING	Shear Mount	
TRIM METHOD	Power Trim and Tilt	
GEAR RATIO	2.08 : 1 Final Drive Ratio	
GEAR SHIFT	F-N-R	
EXHAUST	Through Prop Hub Exhaust	
DRIVE PROTECTION	Rubber Hub	
PROPELLER SIZE (in.)	3 x 16 x 17	3 x 15-1/2 x 17
3 or 4-BLADE STAINLESS STEEL TYPE (OPTIONAL)	3 x 16 x 18.5	3 x 15-1/4 x 19
	3 x 16 x 20	3 x 14-3/4 x 21
	3 x 16 x 21.5	3 x 14-3/4 x 23
	3 x 16 x 23	3 x 14-1/2 x 25
	3 x 16 x 24.5	3 x 14-1/2 x 27
	3 x 16 x 26	4 x 14-1/2 x 28
	3 x 16 x 27.5	4 x 14-1/2 x 29
		4 x 14-1/2 x 30
		4 x 14-1/2 x 31
		4 x 14-1/2 x 32

* The weight of the motors are "Dry-Weight", not including propeller.

* Boats and motors come in a large variety of combinations. See your authorized dealer for correct prop. selection to meet recommended RPM range at W.O.T.

Please read your owner's manual carefully. Remember, boating and alcohol or other drugs don't mix. Always use a personal flotation device. Please operate your outboard safely and responsibly. Suzuki encourages you to operate your boat safely and with respect for the marine environment.

SUZUKI MOTOR CORPORATION reserves the right to change, without notice or obligation, equipment, specifications, colors, materials and other items to apply to local conditions.

Each model may be discontinued without notice. Please inquire at your local dealer for details of any such changes.

Actual body colors may differ slightly from the colors in this brochure.

DIMENSIONS

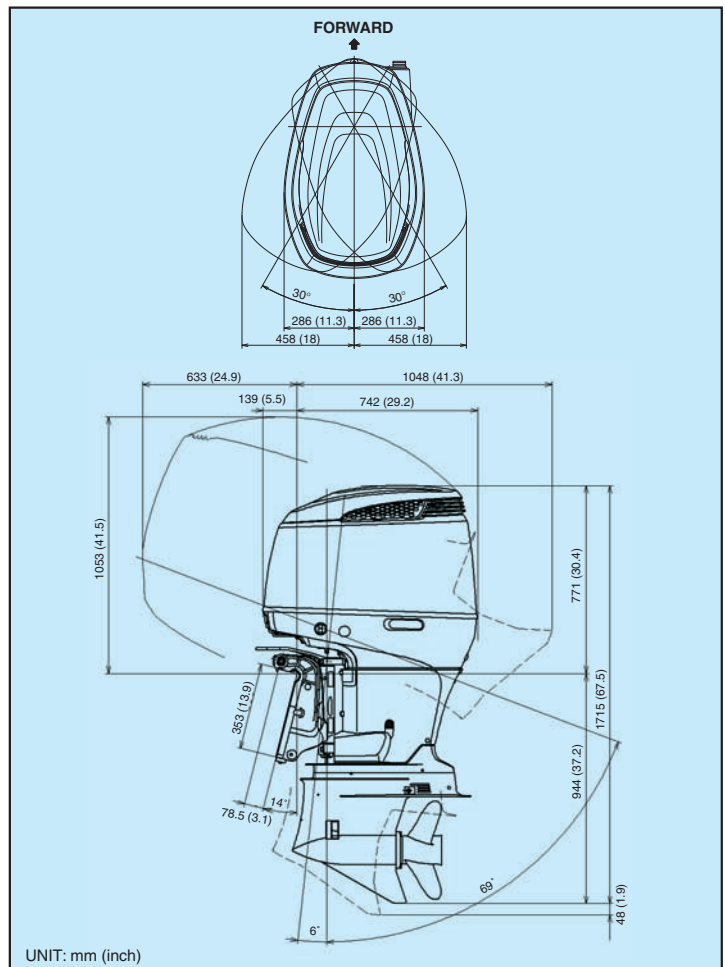

CARB Three-Star Label

The three-star label identifies engines that meet the California Air Resources Board's 2008 exhaust emission standards. Engines meeting these standards have 65% lower emissions than EPA 2006 exhaust emission standards.



AMERICAN SUZUKI MOTOR CORPORATION
P.O. BOX 1100 BREA, CA 92822-1100
<http://www.suzuki.com>

DF250S Product Information 0705
99999-C2049-101

Free Manuals Download Website

<http://myh66.com>

<http://usermanuals.us>

<http://www.somanuals.com>

<http://www.4manuals.cc>

<http://www.manual-lib.com>

<http://www.404manual.com>

<http://www.luxmanual.com>

<http://aubethermostatmanual.com>

Golf course search by state

<http://golfingnear.com>

Email search by domain

<http://emailbydomain.com>

Auto manuals search

<http://auto.somanuals.com>

TV manuals search

<http://tv.somanuals.com>