

SHARP®

ELECTRONIC CASH REGISTER

MODEL
ER-A440S

INSTRUCTION MANUAL



CAUTION:

The cash register and the remote drawer should be securely fitted to the supporting platforms to avoid instability when the drawers are open.

CAUTION:

The socket-outlet shall be installed near the equipment and shall be easily accessible.

VORSICHT:

Die Netzsteckdose muß nahe dem Gerät angebracht und leicht zugänglich sein.

ATTENTION:

La prise de courant murale devra être installée à proximité de l'équipement et devra être facilement accessible.

AVISO:

El tomacorriente debe estar instalado cerca del equipo y debe quedar bien accesible.

VARNING:

Det matande vägguttaget skall placeras nära apparaten och vara lätt åtkomligt.

CAUTION:

For a complete electrical disconnection pull out the mains plug.

VORSICHT:

Zur vollständigen elektrischen Trennung vom Netz den Netzstecker ziehen.

ATTENTION:

Pour obtenir une mise hors-circuit totale, débrancher la prise de courant secteur.

AVISO:

Para una desconexión eléctrica completa, desenchufar el enchufe de tomacorriente.

VARNING:

För att helt koppla från strömmen, dra ut stickproppen.

This equipment complies with the requirements of Directives 89/336/EEC and 73/23/EEC as amended by 93/68/EEC.

Dieses Gerät entspricht den Anforderungen der EG-Richtlinien 89/336/EWG und 73/23/EWG mit Änderung 93/68/EWG.

Ce matériel répond aux exigences contenues dans les directives 89/336/CEE et 73/23/CEE modifiées par la directive 93/68/CEE.

Dit apparaat voldoet aan de eisen van de richtlijnen 89/336/EEG en 73/23/EEG, gewijzigd door 93/68/EEG.

Dette udstyr overholder kravene i direktiv nr. 89/336/EEC og 73/23/EEC med tillæg nr. 93/68/EEC.

Quest' apparecchio è conforme ai requisiti delle direttive 89/336/EEC e 73/23/EEC, come emendata dalla direttiva 93/68/EEC.

Η εγκατάσταση αυτή ανταποκρίνεται στις απαιτήσεις των οδηγιών της Ευρωπαϊκής Ένωσης 89/336/ΕΟΚ και 73/23/ΕΟΚ, όπως οι κανονισμοί αυτοί συμπληρώθηκαν από την οδηγία 93/68/ΕΟΚ.

Este equipamento obedece às exigências das directivas 89/336/CEE e 73/23/CEE, na sua versão corrigida pela directiva 93/68/CEE.

Este aparato satisface las exigencias de las Directivas 89/336/CEE y 73/23/CEE, modificadas por medio de la 93/68/CEE.

Denna utrustning uppfyller kraven enligt riktlinjerna 89/336/EEC och 73/23/EEC så som komplette ras av 93/68/EEC.

Dette produktet oppfyller betingelsene i direktivene 89/336/EEC og 73/23/EEC i endringen 93/68/EEC.

Tämä laite täyttää direktiivien 89/336/EEC ja 73/23/EEC vaatimukset, joita on muutettu direktiivillä 93/68/EEC.

INTRODUCTION

Thank you very much for your purchase of the SHARP Electronic Cash Register, Model ER-A440S. Please read this manual carefully before operating your machine in order to gain full understanding of functions and features.

Please keep this manual for future reference. It will help you, if you encounter any operational problems.

IMPORTANT

- **Install your register in a location that is not subject to direct sunlight, unusual temperature changes, high humidity or exposure to water sources and keep away from heat and magnetic sources.**
Installation in such locations could cause damage to the cabinet and the electronic components.
- **The register should not be operated by an individual with wet hands.**
The water could seep into the interior of the register and cause component failure.
- **When cleaning your register, use a dry, soft cloth. Never use solvents, such as benzine and/or thinner.**
The use of such chemicals will lead to discoloration or deterioration of the cabinet.
- **The register plugs into any standard wall outlet (Official (nominal) voltage).**
Other electrical devices on the same electrical circuit could cause the register to malfunction.
- **If the register malfunctions, call your local dealer for service - do not try to repair the register yourself.**
- **For a complete electrical disconnection, pull out the mains plug.**

PRECAUTION

This Electronic Cash Register has a built-in memory protection circuit which is operated by rechargeable batteries.

As you know, all batteries will, in time, dissipate their charge even if not used. Therefore to insure an adequate initial charge in the protection circuit, and to prevent any possible loss of memory upon installation, it is recommended that each unit be allowed to recharge for a period of 24 to 48 hours prior to use by the customer. In order to charge the batteries, the machine must be plugged in. This recharging precaution can prevent unnecessary initial service calls.

CONTENTS

INTRODUCTION.....	1
IMPORTANT.....	1
PRECAUTION.....	1
CONTENTS.....	2
EXTERNAL VIEW	7
Front view.....	7
Rear view.....	7
PRINTER	8
KEYBOARD	9
1 Standard keyboard layout.....	9
2 Standard key number layout.....	10
KEYS AND SWITCHES	11
1 Mode switch and mode keys.....	11
2 Drawer lock key.....	11
DISPLAYS	12
Machine state symbols.....	12

FOR THE MANAGER

PRIOR TO PROGRAMMING	13
1 General instructions.....	13
2 How to program alphanumeric characters.....	13
Using character keys on the keyboard.....	13
Entering character codes.....	14
PROGRAMMING	16
Preparations for Programming.....	16
Direct Programming	16
1 Setting the date and time.....	16
Date.....	16
Time.....	17
2 Programming for departments.....	17
Unit price.....	17
Functional selection.....	18
3 Price lookup (PLU) programming.....	20
Unit price.....	20
Functional selection.....	20
PLU assignment to departments.....	22
4 European Article Number(EAN)/Universal Product Code(UPC) programming.....	23
Unit price.....	23
Functional selection.....	24
EAN assignment to departments.....	26
5 Programming for discount keys.....	27
Deduction amount (⊖).....	27
High amount lockout (HALO) and +/- sign (⊖).....	28
6 Programming for percent keys.....	29
Percent rate (%).....	29
Sign (+/-) (%).....	29
7 Programming for exchange keys.....	30
Currency exchange rate (EX).....	30
8 Programming for the CA2, RA, PO, CH and CR keys.....	30
High amount lockout (HALO) (CA2, RA, PO, CH, and CR).....	30

9	Programming the tax rate	31
	Tax rate	31
Job-Code-Based Programming	32
1	Setting the date and time	32
	Setting the date (#2610)	32
	Setting the time (#2611)	32
2	Setting the register and consecutive numbers	33
	Setting the register number (#2612)	33
	Setting the consecutive number (#2613)	33
3	Programming the tax rate	34
	Tax rate (#2711)	34
4	Programming for departments	35
	Functional programming (#2110)	35
	Tax status (#2111)	36
	A limit amount (HALO) of entry (#2112)	37
	Alphanumeric characters (#2114)	38
	Unit price (#1110)	38
	Commission group assignment (#2115)	39
	Group number (#2116)	40
	Department key positioning (#2119)	41
5	Price lookup (PLU) programming	42
	Department assignment (#1200, 2230)	43
	Unit prices (#1210)	44
	Base quantity (#1211)	44
	PLU/subdepartment mode (#2210, 2231)	45
	Sign (+/-) and tax status (#2211, 2232)	46
	Alphanumeric characters (#2214)	47
	Assigning of PLUs to commission groups (#2215, 2235)	48
	Link PLU (#2220)	49
	Direct PLU key positioning (#2219)	49
6	European Article Number (EAN) or Universal Product Code (UPC) programming	50
	EAN or UPC code	50
	Add-on code	52
	EAN/UPC programming	52
	Department assignment (#1000)	53
	Unit prices (#1010)	54
	Base quantity (#1011)	54
	Delete method (#2010)	55
	Sign (+/-) and tax status (#2011)	56
	Alphanumeric characters (#2014)	57
	EAN link (#2030)	58
	Delete period for non-accessed EAN codes (#2029)	58
	Programming Non-PLU code format (#2025)	59
	Press code functional programming (#2035)	60
7	Programming for miscellaneous keys	61
	Programming the rate (%, EX, commission) and the deduction (⊖) (#1310)	61
	Programming the number of digits after decimal point for exchange keys (#2330)	62
	Currency description text programming (#2334)	62
	Assigning the drawer number to the drawer for foreign currency (#2680)	63
	A limit amount (HALO) of entry (⊖, RA, PO) (#2312)	63
	+/- sign (%, ⊖) (#2311)	64
	Item % or subtotal % selection (%) (#2315)	65
	Percent rate limitation (%) (#2313)	65
	Item ⊖ or subtotal ⊖ selection (⊖) (#2316)	66

8	Programming for the TL , CA2 , CH1 through CH4 , and CR1 through CR4 keys	67
	Functional programming (#2320)	67
	High amount lockout (HALO) for cheque change, cheque cashing, and cash in drawer (#2321)	68
	High amount lockout (HALO) of entry for media keys (#2322)	69
9	Programming of function text	69
	Programming (#2314)	69
	List of function texts	70
10	Cashier and clerk programming	71
	Cashier code (#1500)	71
	Cashier name (#1514)	72
	Functional programming for cashiers (#2510)	72
	Clerk code (#1400)	73
	Clerk name (#1414)	73
11	Programming various functions	74
	Programming for optional feature selection (#2616)	74
	Programming the limit on the number of times of validation printing and feed line after printing of a difference subtotal (#2615)	79
	Programming alarm length of time with drawer opening (#2617)	79
	Programming of print messages (#2614)	80
	Selection of X1/Z1 and X2/Z2 reports to be printed in the stacked report sequence (#2620)	81
	Setting the time range for hourly reports (#2619)	82
	RS-232C channel assignment (#2690)	82
	Barcode reader programming (#2691)	83
	Secret codes to control access to the PGM1 mode, X1/Z1 mode and X2/Z2 mode (#2630, 2631, 2632)	84
	Setting the AUTO key - Automatic sequencing key - (#2900)	85
12	Reading stored programs	86
	Program details and procedures for their reading	86
	Sample printouts	87
13	Training mode	93
	READING (X) AND RESETTING (Z) OF SALES TOTALS	94
1	Summary of reading (X) and resetting (Z) reports and the key operations to obtain the reports	94
2	Daily sales totals	97
	Full reading and resetting of sales totals	97
	Cashier reading and resetting	101
	Clerk reading and resetting	103
	Reading and resetting of hourly sales information	104
	Full department reading	105
	Individual group reading	106
	Full group reading	106
	Reading and resetting of sales information for a range of PLUs/subdepartments	107
	Reading of sales information on PLUs/subdepartments associated with an individual department	108
	Reading of PLUs/subdepartments whose sales amounts are zeros	108
	Reading of PLU/subdepartments whose sales amounts are zeros (by associated department)	108
	Reading of sales information for the price amount range of PLUs/subdepartments	108
	Reading and resetting of sales information for EANs	109
	Reading and resetting of sales information for EANs associated with an individual department	110
	Reading of EANs whose sales amounts are zero	110
	Reading of EANs whose sales amounts are zeros (by associated department)	110
	Reading of commission sales information	111
	Transaction reading	111
	Total in drawer reading	111
	Reading and resetting of a stacked report	112
	Deleting of non-accessed EANs	112

3	Periodic consolidation.....	113
	Generality	113
	Reading and resetting of daily net totals	114
	Reading and resetting of a stacked report.....	114
	COMPULSORY CASH/CHEQUE DECLARATION	115
	PROGRAMMING FOR EURO	117
	Automatic modification of register system for introduction of EURO.....	118
	Optional programming for the introduction of EURO.....	119
	OVERRIDE ENTRIES	120
	CORRECTION AFTER FINALIZING A TRANSACTION (AFTER GENERATING A RECEIPT)	121

FOR THE OPERATOR

PRIOR TO ENTRIES	122
1 Preparations for entries	122
Receipt and journal paper rolls.....	122
Receipt ON/OFF function	122
Cashier and clerk assignment	122
2 Error warning.....	123
ENTRIES	124
1 Item entries.....	124
Single item entries	124
Repeat entries	125
Multiplication entries	126
Successive multiplication entries.....	127
Split-pricing entries	128
Single item cash sale (SICS)/single item finalize (SIF) entries.....	129
Link PLU/EAN link entries	129
EAN learning function.....	130
Price inquiry (view) function (for EANs).....	131
Price change function (for EANs)	132
2 Displaying subtotals.....	134
Normal subtotal	134
Difference subtotal (Differ ST)	134
3 Finalization of transaction.....	135
Cash or cheque tendering	135
Mixed tendering (cheque + cash)	135
Cash or cheque sale that does not need any tender entry.....	135
Credit sale	136
Mixed-tender sale (cash or cheque tendering + credit tendering)	136
4 Computation of VAT (Value Add Tax)/tax	136
VAT/tax system	136
VAT shift entries	138
5 Auxiliary entries	138
Percent calculations (premium or discount)	138
Deduction entries.....	139
Refund entries	139
Printing of non-add code numbers	140
6 Payment treatment	140
Currency exchange	140
Received on account entries	141
Paid out entries.....	141
No sale (exchange)	142
Cashing a cheque.....	142
7 Automatic sequencing key (AUTO key) entries.....	142

CORRECTION	143
1 Correction of the last entry (direct void).....	143
2 Correction of the next-to-last or earlier entries (indirect void).....	144
3 Subtotal void	144
4 Correction of incorrect entries not handled by the direct or indirect void function	144
SPECIAL PRINTING FUNCTIONS	145
1 Copy receipt printing.....	145
2 Guest check copy	146
3 Validation printing function	146
Validation slip setting and printing	146
Validation printing examples.....	147
Validation slip specification.....	149
4 Printing of the employee arrival and departure times	149
OVERLAPPED CASHIER ENTRY	150
OPERATOR MAINTENANCE	151
1 In case of power failure	151
2 In case of printer's motor locking	151
3 Paper roll near-end sensing function (only for the journal paper) <option>.....	151
4 Installing and removing the paper roll.....	152
Recording paper specifications	152
Installing the paper roll	152
Removing the paper roll	153
Removing a paper jam	154
5 Installing the ink ribbon cassette	155
6 Removing the till and the drawer	156
7 Opening the drawer by hand	156
8 Installing the fixing angle bracket	157
9 Before calling for service	158
Error code table	158
LIST OF OPTIONS	159
SPECIFICATIONS	160

EXTERNAL VIEW

■ Front view

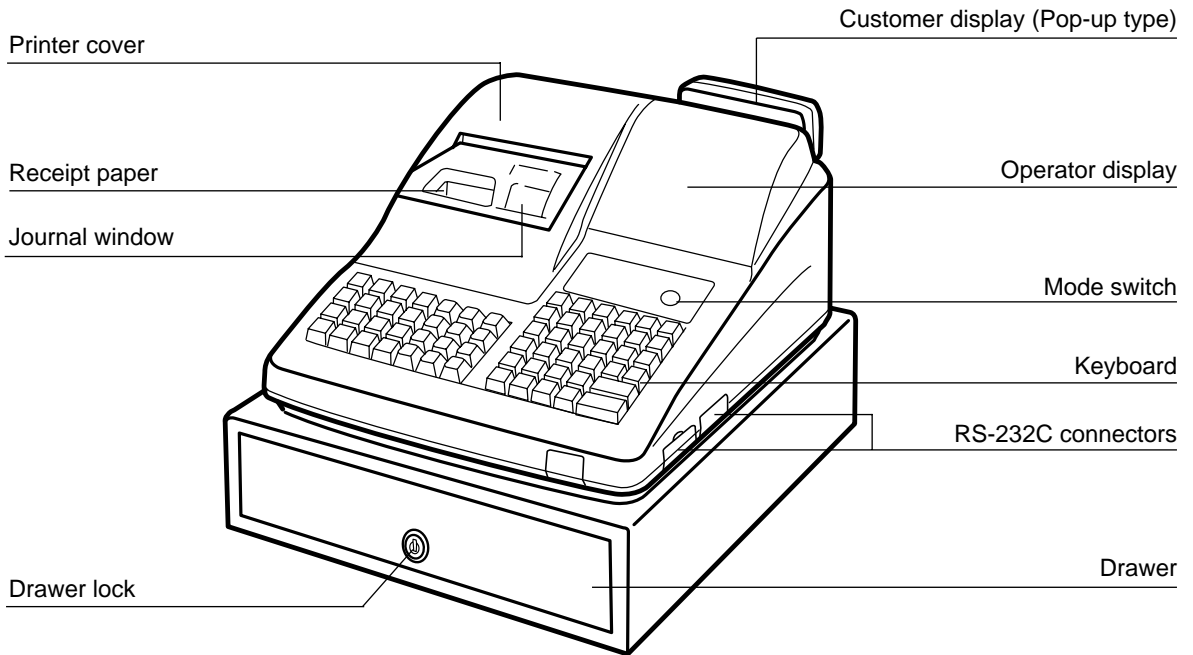

■ Rear view

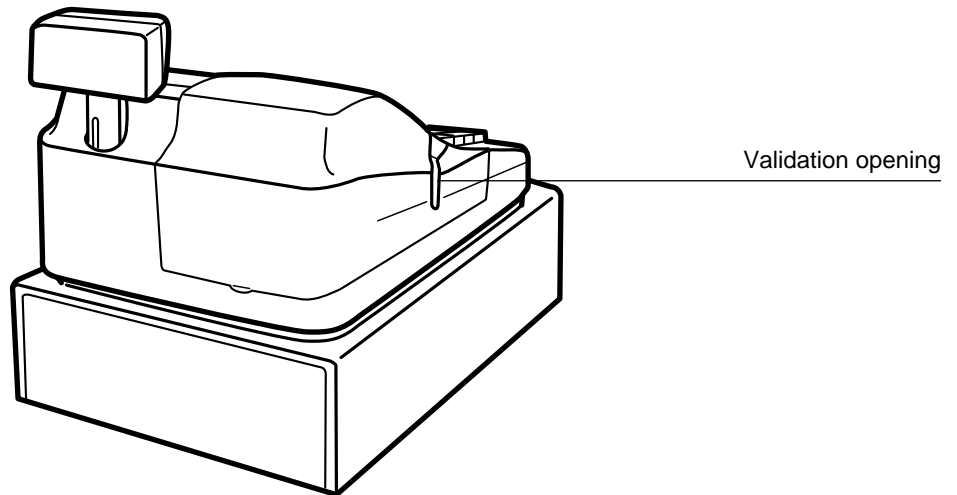

PRINTER

INSTALLING AND REMOVING THE PRINTER COVER

When removing the printer cover, lift up its rear. When installing the printer cover, hook it on the pawls on the cabinet and shut it.

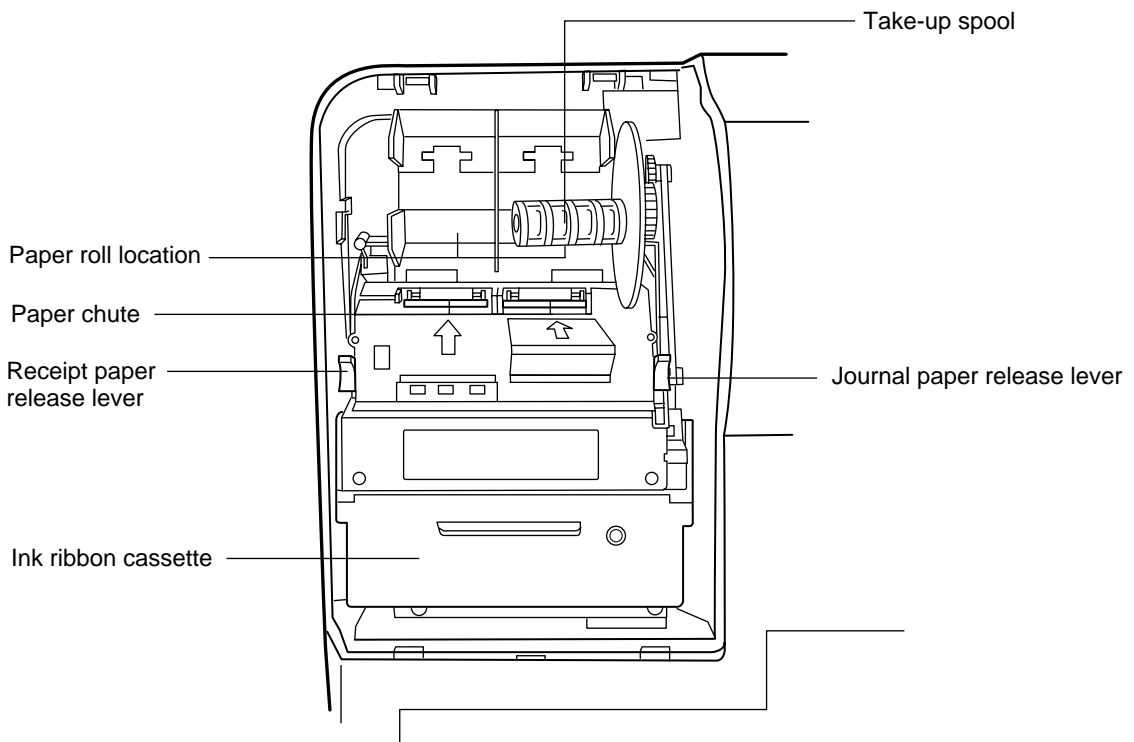
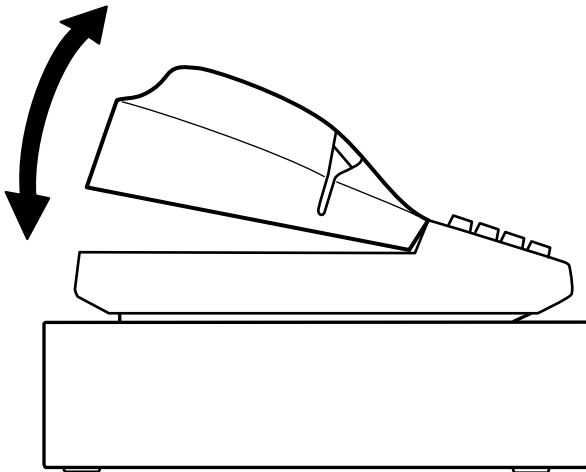

• Paper release lever

Used to load or unload the machine with paper roll (receipt and journal paper). Keep the lever down to take in or out the paper roll.

Note

Do not attempt to take in or out the paper roll without pressing this lever. This may result in damage to the printer.

KEYBOARD

1 Standard keyboard layout

↑ RECEIPT	↑ JOURNAL	#	CL	7	8	9	PLU/ SUB	EAN	AMT	INQ	VAT	CASH #
RCPT	⊖	NS	⊗	4	5	6	5	10	15	20	EX1	EX2
%1	PO	RA	AUTO 1	1	2	3	4	9	14	19	CR1	CR2
%2	RF	∞	AUTO 2	0	00	•	3	8	13	18	CH1	CH2
							2	7	12	17	ST	
							1	6	11	16	TL	

Note

All the keys but the receipt paper feed and journal paper feed keys can be re-positioned. If you want to change the layout, contact your dealer.



Receipt paper feed key



Journal paper feed key



0

}



9

Numeric keys



00



•

Decimal point key



⊗

Multiplication/split-pricing key



CL

Clear key



1

}



20

Department keys



PLU/
SUB

Price lookup/subdepartment key



AMT

Amount entry key



EAN

EAN code entry key



INQ

EAN inquiry key



VAT

Value added tax key



#

Non-add code key



CASH
#

Cashier code entry key



RCPT

Receipt print key



⊖

Discount key



AUTO
1



AUTO
2

Automatic sequencing 1 and 2 keys



%1



%2

Percent 1 and 2 keys



NS

No-sale key



RA

Received-on-account key



PO

Paid-out key



RF

Refund key



∞

Void key



EX1



EX2

Foreign currency exchange
1 and 2 keys

<input type="text" value="CR1"/>	} Credit 1 and 2 keys	* <input type="text" value="CR3"/>	} Credit 3 and 4 keys
<input type="text" value="CR2"/>		* <input type="text" value="CR4"/>	
<input type="text" value="CH1"/>	} Cheque 1 and 2 keys	* <input type="text" value="CA2"/>	Cash total 2 key
<input type="text" value="CH2"/>		* <input type="text" value="EX3"/>	} Foreign currency exchange 3 and 4 keys
<input type="text" value="ST"/>	Subtotal key	* <input type="text" value="EX4"/>	
<input type="text" value="TL"/>	Total (cash total) key	* <input type="text" value="CH3"/>	} Cheque 3 and 4 keys
* <input type="text" value="000"/>	Numeric key	* <input type="text" value="CH4"/>	
* <input type="text" value="21"/>	} Department keys	* <input type="text" value="VAT
SHIFT"/>	Value added tax shift key
* <input type="text" value="50"/>		* <input type="text" value="DIFFER
ST"/>	Difference subtotal key
* <input type="text" value="%3"/>	} Percent 3 and 4 keys	* <input type="text" value="VP"/>	Validation print key
* <input type="text" value="%4"/>		* <input type="text" value="1/2"/>	1/2 key
* <input type="text" value="⊖2"/>	} Discount 2 through 4 keys	* <input type="text" value="CLERK
#"/>	Clerk code entry key
* <input type="text" value="⊖4"/>		* <input type="text" value="1"/>	} Direct price lookup/subdepartment keys
* <input type="text" value="GC
COPY"/>	Guest check copy key	* <input type="text" value="68"/>	
* <input type="text" value="AUTO
3"/>	} Automatic sequencing 3 through 10 keys	* <input type="text" value="DEPT
#"/>	Department code entry key
* <input type="text" value="AUTO
10"/>		* <input type="text" value="NON
DELETE"/>	Non delete key
* <input type="text" value="RA2"/>	Received-on-account 2 key	* <input type="text" value="PRICE
CHANGE"/>	Price change key
* <input type="text" value="PO2"/>	Paid-out 2 key	* <input type="text" value="REPEAT"/>	Repeat entry key

Note The standard keyboard is not equipped with those keys that are marked with (*).

2 Standard key number layout

These key numbers are used for positioning of department keys and direct PLU keys. Refer to pages 41 and 49. This layout can be changed by your dealer.

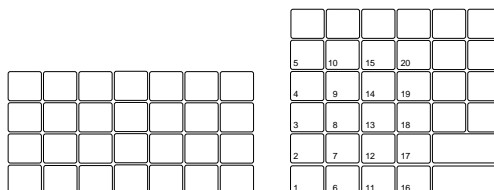

KEYS AND SWITCHES

1 Mode switch and mode keys

The mode switch can be operated by inserting one of the three supplied mode keys - manager (MA), submanager (SM), and operator (OP) keys. These keys can be inserted or removed only when the switch is in the "REG" or "⏻" position.

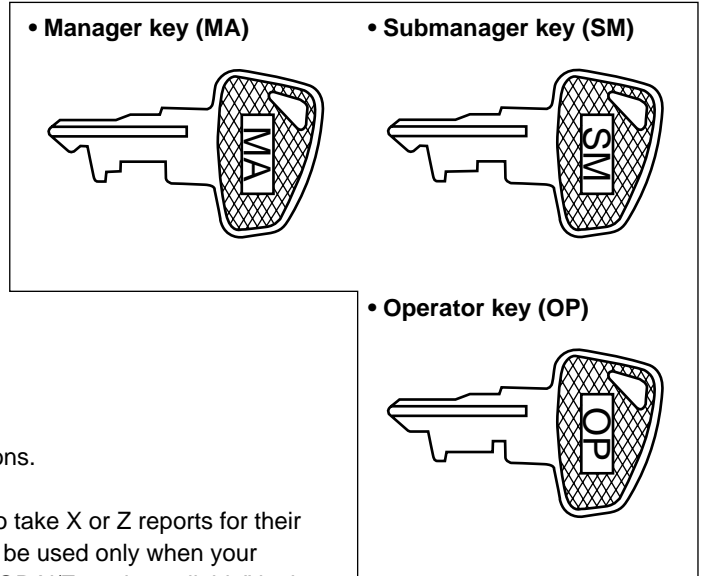
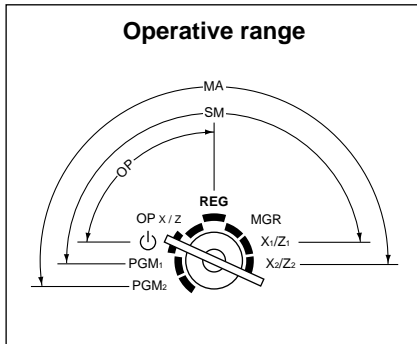

The mode switch has these settings:

- ⏻ : This mode locks all register operations. No change occurs to register data.
- OP X/Z:** This setting allows cashiers/clerks to take X or Z reports for their sales information. (This setting may be used only when your register has been programmed for "OP X/Z mode available" in the PGM2 mode.) It can also be used for displaying the time and printing the employee arrival and departure times. And it can be used to toggle receipt state "ON" and "OFF" by pressing the **RCPT** key.
- REG:** For entering sales
- PGM1:** To program those items that need to be changed often: e.g., unit prices of departments or PLUs, and percentages
- PGM2:** To program all PGM1 items and those items that do not require frequent changes: e.g., date, time, or a variety of register functions
- MGR:** For manager's and submanager's entries
The manager can use this mode to make entries that are not permitted to be made by cashiers - for example, after-transaction voiding and override entry.
- X1/Z1:** To take the X/Z report for various daily totals
- X2/Z2:** To take the X/Z report for various periodic (weekly or monthly) consolidation

2 Drawer lock key

This key locks and unlocks the drawer. To lock it, turn 90 degrees counterclockwise. To unlock it, turn 90 degrees clockwise.

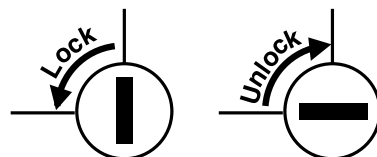
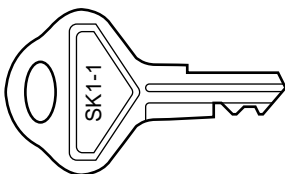

DISPLAYS

Operator display

Customer display (Pop-up type)

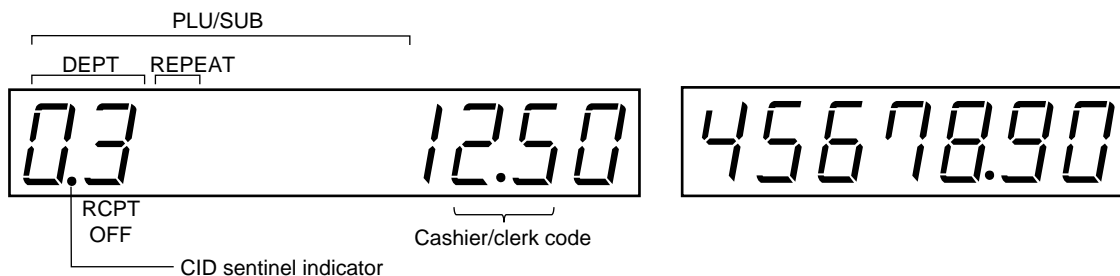

Amount: Appears in the far-right eight (max.) positions.

Cashier code: Appears in the second and third positions (two digits).

Clerk code: Appears in the second and third positions (two digits) with "C" in the fifth position.

Number of repeats for repetitive registrations:

The number of repeats is displayed, starting at "2" and incremented with each repeat.

When you have registered ten times, the display will show "0."

Example: (2 → 3 → 4 9 → 0 → 1 → 2 ...)

Receipt function status:

The indicator "_" appears in the ninth position when the receipt function is put in the OFF status.

Time: Appears in the second to sixth positions (using 24-hour format) in the OP X/Z, REG, or MGR mode. In the REG, or MGR mode, press the key to display the time.

Machine state symbols

\overline{P} : Appears in the tenth place during programming.

\overline{E} : Appears in the tenth place when an error is detected.

- (Floating): Appears when a minus department, PLU/subdepartment or EAN entry is made or when a discount, refund, or void entry is made.

\square : Appears in the tenth place when the subtotal is displayed or when the amount tendered is smaller than the sale amount.

\square : Appears in the tenth place when the through key is pressed to calculate a subtotal in foreign currency.

\overline{F} : Appears in the tenth place when a transaction is finalized by pressing the , , through , or through key.

\overline{C} : Appears in the tenth place when the change due amount is displayed or when the cash/cheque declaration is compulsory.

\overline{U} : Appears in the tenth place when the validation printing is compulsory.

\overline{V} : Appears in the tenth place when the key is pressed in the MGR mode, indicating the entry into the VOID mode. While your register is in the VOID mode, this symbol continues to be in the display except when department codes, PLU codes, EAN codes or subtotals are displayed. Also appears when a subtotal void is made.

• : Appears right below the tenth place when the cash in drawer amount exceeds a programmed sentinel amount. The sentinel check is performed for the total cash in drawer. Also appears right below the eighth place when the VAT shift is effective.

PRIOR TO PROGRAMMING

1 General instructions

This chapter illustrates how to program your cash register.

All the programming items can be programmed by the **Job-Code-Based Programming** described later. However, your machine allows you to program some items using the **Direct Programming**, which does not require you to enter the job code.

Job-Code-Based Programming

Simplified procedure

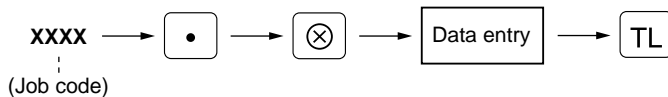

Direct Programming

Sample procedure

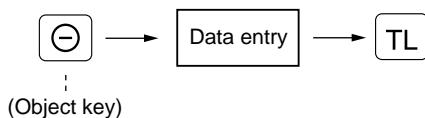

2 How to program alphanumeric characters

You can program alphanumeric characters for departments, PLUs, EANs, functions and so on in the character entry mode.

There are two ways for programming characters: using character keys on the keyboard and entering character codes with numeric keys on the keyboard.

Using character keys on the keyboard

Enter a character according to the position of the figure shown below.

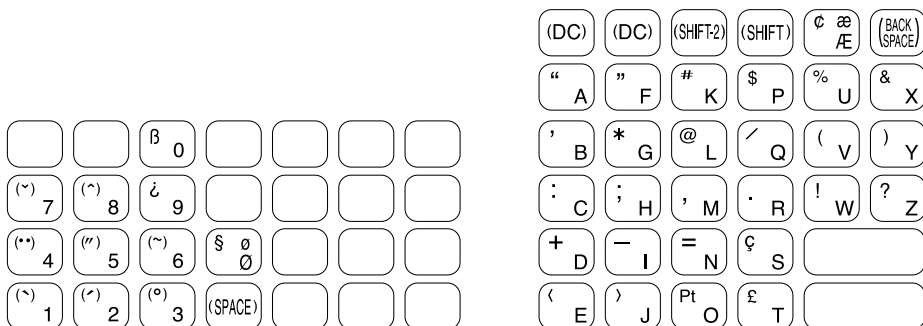

[Ex.]

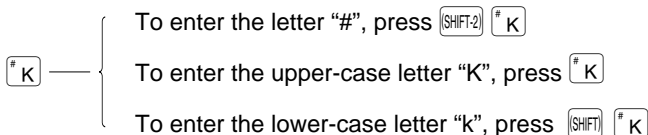

- Numerals, letters and symbols are programmable simply by pressing the corresponding keys.
- Characters may only be entered in single size or in double size. **By default, the single-size character mode is selected.** To enter a character in double size, press the (DC) key before you enter the corresponding character.

Example

To program the word “SHARP” in double size, do the following key-in.

(DC) S (DC) H (DC) A (DC) R (DC) P

- Letters of alphabets “A” through “Z”, “Ø” and “Æ” are possible to be entered in lower case or in upper case. **By default, the upper-case letter mode is selected.** To enter a character in lower case, press the (SHIFT) key before you enter the character. To return to the upper-case letter mode, press the (SHIFT) key again.

Example

To program the word “Sharp”, do the following key-in.

S (SHIFT) H A R P

- Symbols and special letters are programmable by using the (SHIFT-2) key. To enter a character, press the (SHIFT-2) key before you enter the corresponding character.

Example

To program letters “# Å Ä” with the letter “#” being double size

(DC) (SHIFT-2) # (SHIFT-2) (••) A (SHIFT-2) (°) A

Editing the characters

You can edit the characters you entered. Pressing a character key replaces the current character with a new one. To edit the characters, use the (BACK SPACE) key.

(BACK SPACE): Backs up the cursor, erasing the character to the left.

■ Entering character codes

- Numerals, letters and symbols are programmable by entering character codes and the (00) key. See the alphanumeric character code table on the next page. In this way, you can program characters other than the characters on the programming key sheet.

XXX → (00) XXX: Character code (3 digits)

- Double-size characters can be made by entering the character code 253.

Example

To program the word “SHARP” with the letter “S” being double size

253 (00) 083 (00) 072 (00) 065 (00) 082 (00) 080 (00)
 S H A R P

Alphanumeric character code table

Code	Character	Code	Character	Code	Character	Code	Character	Code	Character
001	á	046	.	091	Ä	136	→	193	ı
002	â	047	/	092	Ö	137	ƒ	194	Ġ
003	ê	048	0	093	Ü	138	∞	195	Ş
004	î	049	1	094	^	139	◀	196	Ğ
005	ì	050	2	095	_	140	▶	197	ġ
006	í	051	3	096	'	141	F	198	Ƙ
007	ô	052	4	097	a	142	T	199	ƙ
008	ó	053	5	098	b	143	↓	200	ƚ
009	û	054	6	099	c	144	ç	201	ƚ
010	ú	055	7	100	d	145	°	202	Ž
011	œ	056	8	101	e	146	ı	203	Đ
012	ú	057	9	102	f	147	Û	204	đ
013	ù	058	:	103	g	148	à	205	Č
014	ř	059	;	104	h	149	Æ	206	č
015	ó	060	<	105	i	150	ø	207	€
016	Λ	061	=	106	j	151	Å	208	Ɔ
017	Ψ	062	>	107	k	152	ǻ	209	˘
018	Γ	063	?	108	l	153	é	210	ě
019	˘	064	@	109	m	154	è	211	š
020	Ω	065	A	110	n	155	Pt	212	č
021	Δ	066	B	111	o	156	i	213	ž
022	Θ	067	C	112	p	157	Ñ	214	ý
023	Ξ	068	D	113	q	158	ò	215	ù
024	Π	069	E	114	r	159	£	216	ň
025	Σ	070	F	115	s	160	¥	217	˘
026	Υ	071	G	116	t	161	◦	218	˘
027	Φ	072	H	117	u	162	Γ	219	ř
028	Ú	073	I	118	v	163	J	224	*
029	Ú	074	J	119	w	164	˘	225	§
030	Ŏ	075	K	120	x	165	˘	226	∅
031	Ŏ	076	L	121	y	177	Á	227	˘
032	(space)	077	M	122	z	178	Í	228	↑
033	!	078	N	123	{	180	Ā	229]
034	"	079	O	124		181	ā	230	[
035	#	080	P	125	}	182	Ē	231	"
036	\$	081	Q	126	ß	183	ē	232	ä
037	%	082	R	127	¢	184	Ī	233	ö
038	&	083	S	128	!!	185	ī	234	ü
039	'	084	T	129	₁	186	Ū	235	æ
040	(085	U	130	₂	187	ū	236	â
041)	086	V	131	₃	188	Ū	237	É
042	*	087	W	132	₄	189	ŋ	238	ñ
043	+	088	X	133	½	190	Č	253	*(DC)
044	,	089	Y	134	F/T	191	Š		
045	-	090	Z	135	←	192	Ç		

*(DC): Double-size character code

PROGRAMMING

Your machine allows you to program in two modes: PGM1 and PGM2. The PGM1 mode is for programming those items that need to be changed often: unit prices of departments/PLUs/EANs and percentages. The PGM2 mode is used for programming all PGM1-mode programs and those items that require less frequent changes: date, time, tax rate, and the functions of each key. We describe below the programming or setting procedures of various items.

Program every item necessary for your store following the appropriate procedures.

* To set the mode switch to the PGM1 position, use the manager or submanager key; and to set to the PGM2 position, use the manager key.

■ Preparations for Programming

1. Plug your machine into a standard wall outlet.
2. Put the manager or submanager key in the mode switch and turn it to the PGM1 or PGM2 position depending upon the programming you are about to do.
3. Check to see whether both journal and receipt rolls are present in the machine. If they are missing, install journal and receipt paper rolls correctly referring to the procedure in "4. Installing and removing the paper roll" under "OPERATOR MAINTENANCE".
4. Program necessary items into your machine.

Direct Programming

1 Setting the date and time

■ Date PGM 2

Enter the day (one or two digits), month (two digits), and year (two digits) in this sequence.

Procedure

X X X X X X → #
Date (five or six digits)

Example

August 26, 2001

Key operation

260801 #

Print

```
26/08/01 0:00
000000 #0001

  *PGM2*

                26/08/01 — Date
```

Time PGM 2

Set the time using the 24-hour format. For example, when the time is set to 2:30 AM, enter 230; and when it is set to 2:30 PM, enter 1430. Once you set the time, the internal clock unit will continue to run as long as the built-in battery is alive and update the date (day, month, year) properly.

Procedure

X X X X → #
Time (max. four digits)

Example Setting the time as 2:30 PM (14:30)

Key operation

1430 #

Print

```

26/08/01 14:30
000000 #0002

*PGM2*

14:30
    
```

Time

2 Programming for departments

Your machine is equipped with 20 standard departments and up to 50 optional departments. Your machine allows you to perform the following programming for each department:

Unit price PGM 1 PGM 2

Procedure

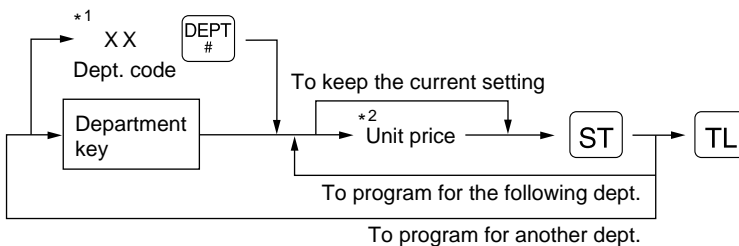

*1 Department code: 1 to 50

*2 Unit price: max. six digits (9999.99)

Example Programming the unit price 10.00 for department 1

- | | | |
|---|--|------------------|
| <p>1. Press the department 1 key.
• The current unit price will be displayed.</p> | 1 | 0 1 0 . 0 0 |
| <p>2. Enter the unit price "1000."</p> | 1000 | 0 1 1 0 0 0 |
| <p>3. Press the ST key to program this setting.</p> | ST | 0 2 0 . 0 0 |
| <p>4. Press the TL key to finalize the programming and generate a programming report.</p> | TL | 0 . 0 0 |

Print

```

      *PGM2*
D01          10.00
DPT.01      601
0000003     0 COL18
    
```

Dept. code
Unit price

Functional selection PGM 2

Procedure

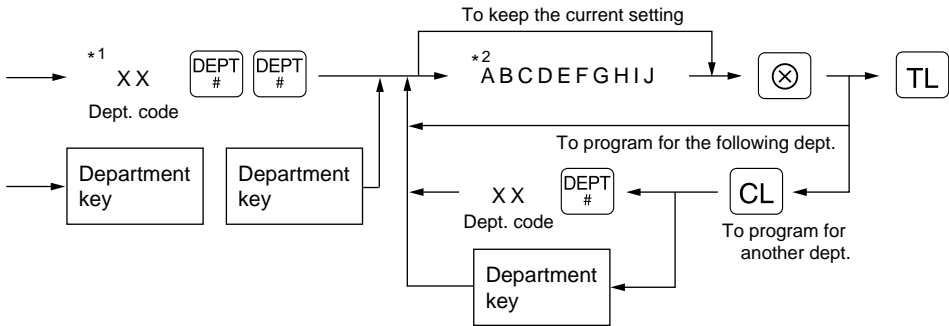

*1 Department code: 1 to 50

*2 Item:

Item:	Selection:	Entry:
A Always enter 0.		0
B VAT6 or TAX6	No	0
	Yes	1
C VAT5 or TAX5	No	0
	Yes	1
D VAT4 or TAX4	No	0
	Yes	1
E VAT3 or TAX3	No	0
	Yes	1
F VAT2 or TAX2	No	0
	Yes	1
G VAT1 or TAX1	No	0
	Yes	1
H Normal/SICS (Single Item Cash Sale)/ SIF (Single Item Finalization)	Normal	0
	SICS	1
	SIF	2
I Significant digit for HALO		1 through 9
J Number of zeros to follow the significant digit for HALO		0 through 8

Note

Tax status

- The tax system of your machine has been factory-set to automatic VAT1-6. If you desire to select any of automatic tax 1-6, manual VAT1-6, manual VAT1, manual tax 1-6, and the combination of the automatic VAT 1-3 and the automatic tax 4-6, consult your dealer.
- When the combination of the automatic VAT1-3 and automatic tax 4-6 system is selected, one of the VAT1(G), VAT2(F) and VAT3(E) can be selected in combination with tax 4-6.
Example: BCDEFG= 100100, 110100, 111010

Normal department/SICS (Single Item Cash Sale) / SIF (Single Item Finalization)

- If an entry of a department programmed for SICS is made first, the sale will be finalized as soon as the department key is pressed. If the entry is made after entering a department not programmed for SICS, the sale will not be finalized until the **[TL]** key is pressed.
- Whenever a sale is made to a department set for SIF, the sale is finalized as soon as the department key is pressed.

HALO (High Amount Lockout)

- You can set an upper limit amount (HALO) for each department. The limit is effective for the REG-mode operations and can be overridden in the MGR mode.
- IJ is the same as $I \times 10^J$.
For example, presetting 14 (100.00) here means that amount entries of up to 100.00 are allowed in the REG mode. When you preset 18, however, the upper limit amount is 999999.99.

Example

Programming for department 4 as follows: A=0, B=0, C=0, D=0, E=0, F=0, G=1, H=0, I=9 and J=5.

A B C D E F G H I J

1. Press the department 4 key twice.

[4] **[4]**

0:0 0 0 0 0 0 0 1 8

- The current parameter setting will be displayed.

2. Set the parameters as follows:

- You can change the value at the blinker.

Go to the desired position with the following keys:

[.].....Moves the blinker to the right.

0:0 0 0 0 0 0 0 1 8



0:0:0 0 0 0 0 0 1 8

[00].....Moves the blinker to the left.

0:0:0 0 0 0 0 0 1 8



0:0:0 0 0 0 0 0 1 8

- Enter the figure.

0000001095

0 0 0 0 0 0 1 0 9:5

3. Press the **[⊗]** key to program this setting.

[⊗]

0:0:0 0 0 0 0 0 1 8

4. Press the **[TL]** key to finalize the programming and generate a programming report.

[TL]

0 . 0 0

Print

```

      XFGM2X
      |-----|-----|
      D04 T1          0.00 Taxable 1
      DFT.04          G01
      0000001        0 COL95 HALO limit
      |-----|-----|
      Normal dept.
  
```

* Item:	Selection:	Entry:
A Sign (plus/minus)	Plus	0
	Minus	1
B VAT6 or TAX6	No	0
	Yes	1
C VAT5 or TAX5	No	0
	Yes	1
D VAT4 or TAX4	No	0
	Yes	1
E VAT3 or TAX3	No	0
	Yes	1
F VAT2 or TAX2	No	0
	Yes	1
G VAT1 or TAX1	No	0
	Yes	1
H Mode	Prohibit mode	0
	Subdepartment mode	1
	PLU mode	2
	PLU/subdepartment mode	3
	Delete mode	4

Note

Sign (plus/minus)

The function of every PLU/subdepartment varies according to the combination of its sign and the sign of its associated department as follows:

Sign		Function of PLU/subdepartment
Department	PLU/ subdepartment	
+	+	Serves as a normal plus PLU/subdepartment
-	-	Serves as a normal minus PLU/subdepartment
+	-	Accepts store coupon entries, but not split-pricing entries
-	+	Not valid; not accepted

Tax status

- The tax system of your machine has been factory-set to automatic VAT1–6. If you desire to select any of automatic tax 1–6, manual VAT1–6, manual VAT1, manual tax 1–6, and the combination of the automatic VAT 1–3 and the automatic tax 4–6, consult your dealer.
- When the combination of the automatic VAT1–3 and automatic tax 4–6 system is selected, one of the VAT1(G), VAT2(F) and VAT3(E) can be selected in combination with tax 4–6.
Example: BCDEFG= 100100, 110100, 111010
- A PLU not programmed for any of these tax statuses is registered depending on the tax status of the department which the PLU belongs to.

Mode parameter

- **PLU mode:** Allows a PLU entry to be made by entering an assigned PLU code and depressing the **[PLU/SUB]** key.
- **Subdepartment mode:** Allows a subdepartment entry to be made by entering a unit price, pressing the **[AMT]** key, assigned PLU code and then pressing the **[PLU/SUB]** key.
- **PLU/subdepartment mode:** Allows PLU entries to be made in both the PLU and subdepartment modes.
- **Delete mode:** Deletes program data for each PLU.
- **Prohibit mode:** Prohibits the entry of any assigned PLU code. This mode does not clear the PLU/subdepartment program data.

Example

Programming for PLU code 1 as follows: A=0, B=0, C=0, D=0, E=0, F=0, G=1, and H=2.

- Enter the PLU code "1" and press the **PLU/SUB** key twice.

	A	B	C	D	E	F	G	H
P	0	0	0	0	0	0	0	2
- Set the parameters A to H.
 - You can go to the desired position with the **00** or **.** key.

P	0	0	0	0	0	0	1	2
---	---	---	---	---	---	---	---	---
- Press the **⊗** key to program this setting.

P	0	0	0	0	0	0	2
---	---	---	---	---	---	---	---
- Press the **TL** key to finalize the programming and generate a programming report.

	0	.	0	0
--	---	---	---	---

Print

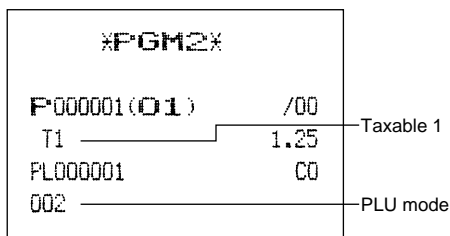

PLU assignment to departments PGM 1 PGM 2

Procedure

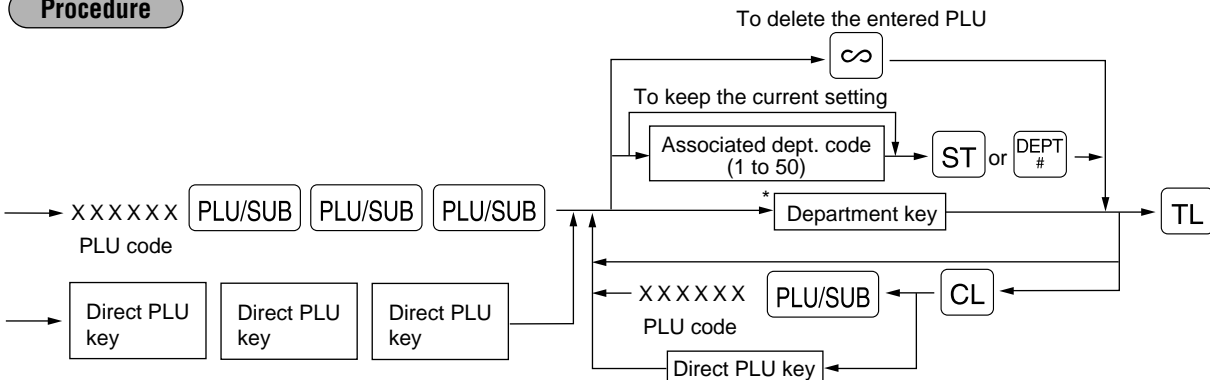

*Department key to be associated with the entered PLU

Note

- The following functions of the PLU depend on the programming for its associated department:
 - Grouping (Group 1 through 14)
 - SICS (Single Item Cash Sale)/SIF (Single Item Finalization)/Normal
 - Item validation print compulsory/non-compulsory
 - HALO (high amount lockout)

Example

Assigning PLU codes 1 and 2 to department 2

- Enter the PLU code "1" and press the **PLU/SUB** key three times.

0	0	0	0	1	0	1
---	---	---	---	---	---	---
- Press the department 2 key to assign PLU code 1 to department 2.

0	0	0	0	2	0	1
---	---	---	---	---	---	---

3. Press the department 2 key to assign
PLU code 2 to department 2.

2

0 0 0 0 0 3 0 1

4. Press the **TL** key to finalize the programming
and generate a programming report.

TL

0 . 0 0

Print

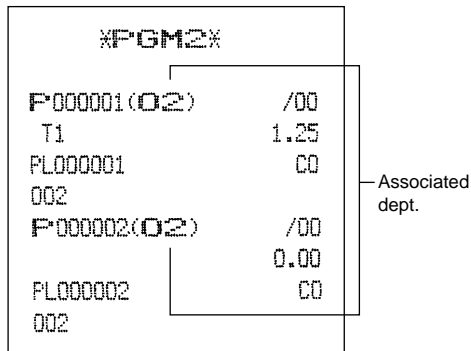

4 European Article Number(EAN)/Universal Product Code(UPC) programming

Unit price PGM 1 PGM 2

Procedure

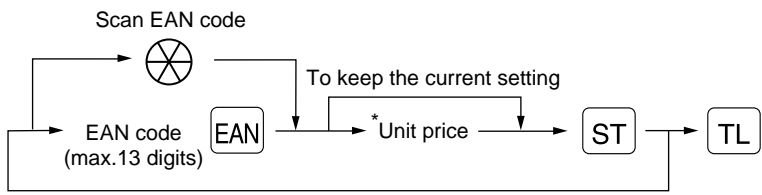

*Unit price: max. six digits (9999.99)

Note • The entry of a EAN (or UPC) code through the scanner is indicated by

Example Programming the unit price 2.50 for EAN code 5012345678900.

1. Scan the EAN code,
or enter the EAN code "5012345678900"
and press the **EAN** key.

or
5012345678900 **EAN**

P 0 . 0 0

2. Enter the unit price "250."

250

P 2 5 0

3. Press the **ST** key to program this setting.

ST

P 0 . 0 0

4. Press the **TL** key to finalize the programming
and generate a programming report.

TL

0 . 0 0

Print

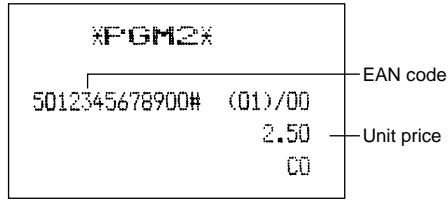

Functional selection PGM 2

Procedure

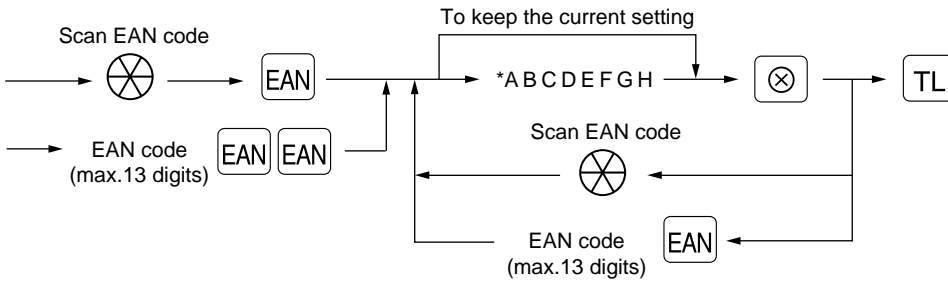

* Item:	Selection:	Entry:
A Sign (plus/minus)	Plus	0
	Minus	1
B VAT6 or TAX6	No	0
	Yes	1
C VAT5 or TAX5	No	0
	Yes	1
D VAT4 or TAX4	No	0
	Yes	1
E VAT3 or TAX3	No	0
	Yes	1
F VAT2 or TAX2	No	0
	Yes	1
G VAT1 or TAX1	No	0
	Yes	1
H Delete method (To erase from the EAN file)	Delete in X/Z non-accessed EAN deleting job (#105 in Z1 mode)	0
	Inhibit to delete in non-accessed EAN deleting job	1
	Delete now	4

Note **Sign (plus/minus)**
The function of every EAN varies according to the combination of its sign and the sign of its associated department as follows:

Sign		Function of EAN
Department	EAN	
+	+	Serves as a normal plus EAN
-	-	Serves as a normal minus EAN
+	-	Accepts store coupon entries, but not split-pricing entries
-	+	Not valid; not accepted

Tax status

- The tax system of your machine has been factory-set to automatic VAT1-6. If you desire to select any of automatic tax 1-6, manual VAT1-6, manual VAT1, manual tax 1-6, and the combination of the automatic VAT 1-3 and the automatic tax 4-6, consult your dealer.
- When the combination of the automatic VAT1-3 and automatic tax 4-6 system is selected, one of the VAT1(G), VAT2(F) and VAT3(E) can be selected in combination with tax 4-6.
Example: BCDEFG= 100100, 110100, 111010
- An EAN not programmed for any of these tax statuses is registered depending on the tax status of the department which the EAN belongs to.

Delete method

- When you select "delete now", the programmed data of the EAN code you specified is deleted with this programming.
- When you select "Delete in X/Z non-accessed EAN deleting job", you can delete EANs that has not been accessed during the period that is programmed in the job #2029 with the execution of EAN deleting job (#105 in Z1 mode).

Example

Programming for EAN code 5012345678900 as follows: A=0, B=0, C=0, D=0, E=0, F=0, G=1, and H=1.

1. Scan the EAN code and press the key, or enter the EAN code "5012345678900" and press the key twice.

or
5012345678900

	A	B	C	D	E	F	G	H
P	0	0	0	0	0	0	0	0

2. Set the parameters A to H.
•You can go to the desired position with the or key.

00000011

P	0	0	0	0	0	0	1	1
---	---	---	---	---	---	---	---	---

3. Press the key to program this setting.

P							0	. 0 0
---	--	--	--	--	--	--	---	-------

4. Press the key to finalize the programming and generate a programming report.

								0 . 0 0
--	--	--	--	--	--	--	--	---------

Print

Delete method _____
(Inhibit to delete by job#105 in Z1 mode)
In case of "delete", no mark is printed.

```

*PGM2*
5012345678900# (01)/00
⊗T1 2.50
_____ 00
    
```

Taxable 1

When "delete now" is selected:

```

*PGM2*
5012345678900# ----
    
```

5 Programming for discount keys

■ Deduction amount (⊖) PGM 1 PGM 2

Procedure

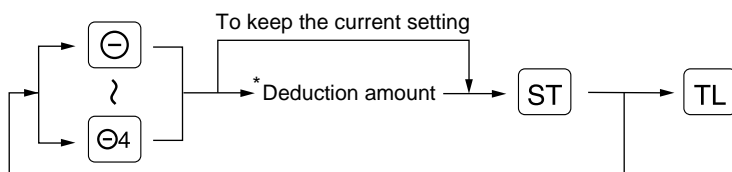

*Deduction amount: 0 - 999999

Example Assigning "10.00" to the ⊖ key

- | | | |
|--|------|----------------------|
| 1. Press the ⊖ key. | ⊖ | 0 0 1 0 . 0 0 |
| 2. Enter the deduction amount "1000." | 1000 | 0 0 1 1 0 0 0 |
| 3. Press the ST key to program this setting. | ST | 0 0 1 1 0 . 0 0 |
| 4. Press the TL key to finalize the programming and generate a programming report. | TL | 0 . 0 0 |

Print

```

  *PGM2*

  F001 (-) 1
  S          -10.00
             L18
  
```

Deduction amount

High amount lockout (HALO) and +/- sign (⊖) PGM 2

Procedure

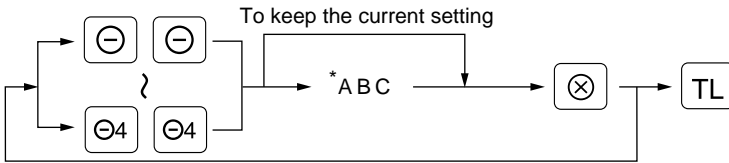

* Item:	Selection:	Entry:
A Sign (plus/minus)	Plus	0
	Minus	1
B Significant digit for HALO		1 through 9
C Number of zeros to follow the significant digit for HALO		0 through 8

Note HALO (High Amount Lockout)

BC is the same as $B \times 10^C$.

For example, presetting 14 (100.00) here means that amount entries of up to 100.00 are allowed in the REG mode. When you preset 18, however, the upper limit amount is 999999.99.

Example Programming for the ⊖ key as follows: A=1, B=1, and C=3.

		A B C
1. Press the ⊖ key twice.	⊖ ⊖	0 0 1 1 1 8
2. Set the parameters A to C. •You can go to the desired position with the 00 or . key.	113	0 0 1 1 1 3
3. Press the ⊗ key to program this setting.	⊗	0 0 1 1 1 3
4. Press the TL key to finalize the programming and generate a programming report.	TL	0 . 0 0

Print

```

XPGM2X
FOO1 (-) 1
S          -10.00
          L13 — HALO limit
    
```

6 Programming for percent keys

Percent rate (%) PGM 1 PGM 2

Procedure

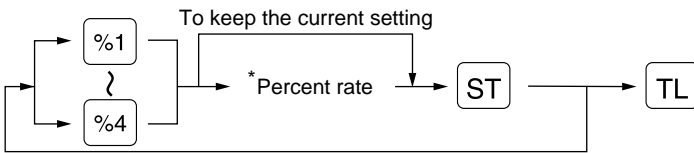

* Percent rate: 0.00 - 100.00

Note You must use a decimal point when setting percentage rates that are fractional.

Example Assigning 10.25% to the %1 key

Key operation

%1 10 . 25 ST
TL

Print

```

*PGM2*

F005 %1
S                -10.25%
                  L100.00%
    
```

Percent rate

Sign (+/-) (%) PGM 2

Procedure

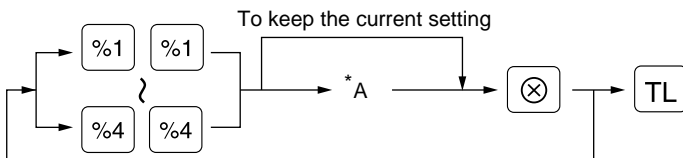

* Item:	Selection:	Entry:
A Sign (plus/minus)	Plus (premium)	0
	Minus (discount)	1

Example Programming minus sign for the %1 key

Key operation

%1 %1 1 ⊗
TL

Print

```

*PGM2*

F005 %1
S                -10.25%
                  L100.00%
    
```

Discount

7 Programming for exchange keys

■ Currency exchange rate (EX) PGM 1 PGM 2

Procedure

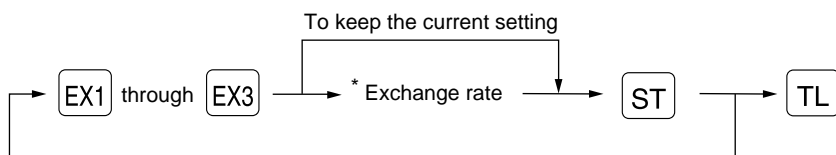

* Currency exchange rate: 0.000000 - 999.999999

Note You must use a decimal point when setting conversion rates that are fractional.

Example Assigning 0.6068 to the EX1 key

Key operation

EX1 0 . 6068 ST
TL

Print

```

    *PGM2X
    F052 EXCH1
    0.606800 Exchange rate
  
```

8 Programming for the CA2, RA, PO, CH and CR keys

■ High amount lockout (HALO) (CA2, RA, PO, CH and CR) PGM 2

Procedure

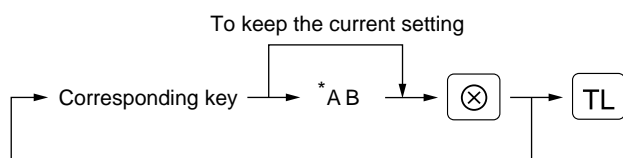

* AB is the same as $A \times 10^B$

A: Significant digit (1 through 9)

B: Number of zeros to follow the significant digit (0 through 8)

Example Programming a HALO limit of 1000.00 (15) for the CR2 key

Key operation

CR2 15 X
TL

Print

```

    *PGM2X
    F049 CREDIT2
    L15 HALO limit
    0000000
  
```

9 Programming the tax rate

Tax rate PGM 2

Procedure

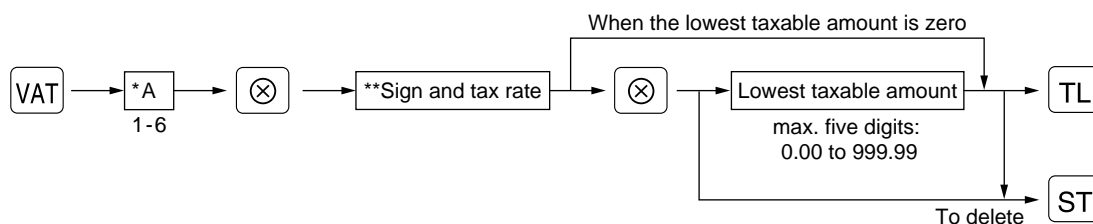

* A: Enter a corresponding tax rate number. For example, when you program a tax rate as tax rate 1, enter “1”, and when you program it as tax rate 6, enter “6”.

** Sign and tax rate: XYYY.YYYY

└ Tax rate= 0.0001 to 100.0000
└ Sign +/- = 1/0

Note

- The lowest taxable amount is valid only when you select add on tax system. If you select VAT (Value added tax) system, it is ignored.
- If you make an incorrect entry before pressing the second ⊗ key in programming a tax rate, cancel it with the CL key; and if you make an error after pressing the second ⊗ key, cancel it with the ST key. Then program again from the beginning.
- If you select VAT system, the sign which you program is ignored.

Example

Programming the tax rate (+4%) as tax rate 2 with lowest taxable income as 0.12.

- | | | |
|--|-----|-----------|
| 1. Press the VAT key. | VAT | P 0 . 0 0 |
| 2. Enter the tax rate “2”. | 2 ⊗ | P 0 . 0 0 |
| 3. Enter the tax rate “+4%.” | 4 ⊗ | P 0 . 0 0 |
| 4. Enter the lowest taxable amount “12.” | 12 | P 1 2 |
| 5. Press the TL key to finalize the programming and generate a programming report. | TL | 0 . 0 0 |

Print

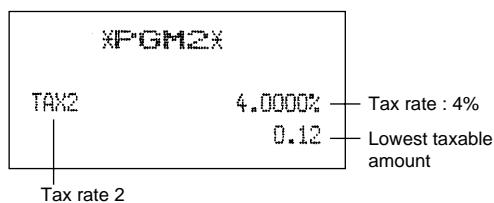

Job-Code-Based Programming

This section illustrates how to program items using job codes. Using job codes allows you to program a wide variety of items in comparison with direct programming.

Start this programming by entering a corresponding job code as shown below.

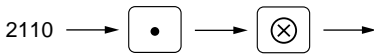

All the items which can be programmed by the job-code-based programming are listed on this page and the following, and those which can also be programmed by the direct programming are marked with the symbol “**Direct**” that follows job codes.

Note

When setting the parameters for a job code, the digit that is blinking is the one that can be changed. To go to the position of the parameter that you want to change, press either of the following keys :

- Moves the blinker to the right.
- 00 Moves the blinker to the left.

1 Setting the date and time

Setting the date

PGM 2

2610

Direct

Enter day (one or two digits), month (two digits), and year (two digits) in this sequence.

Procedure

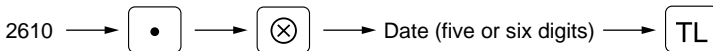

Example

Key operation

2610 [•] [⊗]
260801 [TL]

Print

```
26/08/01 0:00  
000000 #0001  
Date #2610 *PGM2*  
26/08/01
```

Setting the time

PGM 2

2611

Direct

Set the time using the 24-hour format. For example, when the time is set to 2:30 AM, enter 230; and when it is set to 2:30 PM, enter 1430.

Procedure

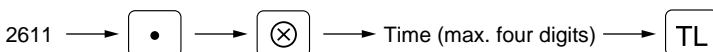

Example**Key operation**

2611
 1430

Print

```

26/08/01 14:30
000000 #0002
#2611 *PGM2*
14:30
  
```

Time

2 Setting the register and consecutive numbers**Setting the register number** PGM 2 **2612**

When your store has two or more registers, it is practical to set separate register numbers for their identification. You may set them in a maximum of six digits.

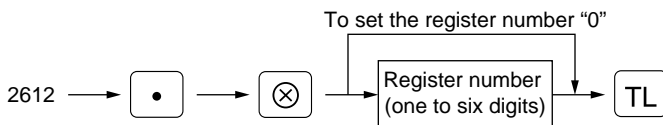
Procedure**Example****Key operation**

2612
 123456

Print

```

26/08/01 14:30
123456 #0003
#2612 *PGM2*
123456
  
```

Register number

Setting the consecutive number PGM 2 **2613**

The consecutive number is increased by one each time a receipt is issued. Enter a number (one to four digits) that is one less than the desired starting number.

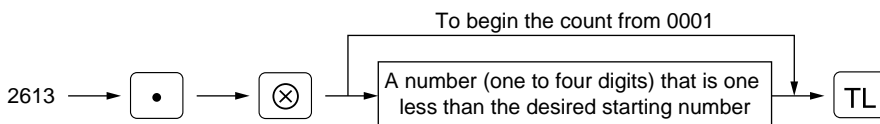
Procedure

Example

Key operation

2613
 1000

Print

```
26/08/01 14:30
123456 #1000
#2613 XPGM2X
1000
```

Consecutive number

3 Programming the tax rate

Tax rate PGM 2 **2711**

Procedure

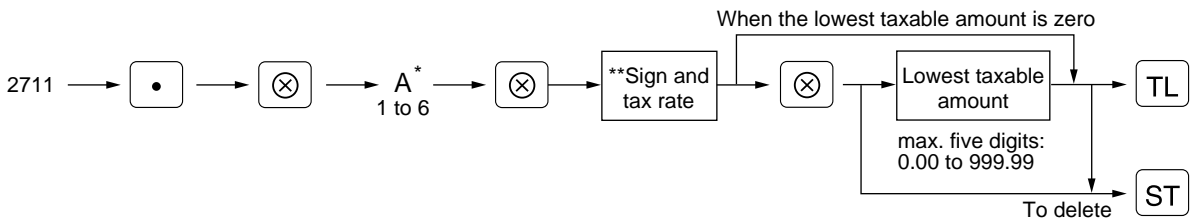

*A: Enter a corresponding tax rate number. For example, when you program a tax rate as tax rate 1, enter 1 and when you program it as tax rate 6, enter 6.

** Sign and tax rate: YYYY.YYYY
 Tax rate= 0.0001 to 100.0000
 Sign +/- = 1/0

Example

Key operation

2711
 2
 4
 12

Print

```
#2711 XPGM2X
TAX2          4.0000% Tax rate : 4%
              0.12    Lowest taxable amount
```

Tax rate 2

Note

- The lowest taxable amount is valid only when you select add on tax system. If you select VAT (Value added system), it is ignored.
- If you make an incorrect entry before pressing the third key in programming a tax rate, cancel it with the key; and if you make an error after pressing the third key, cancel it with the key. Then program again from the beginning correctly.
- If you select VAT system, the sign which you program is ignored.

4 Programming for departments

Your machine is equipped with 20 standard departments and up to 50 optional departments. Your machine allows you to perform the following programming for each department:

■ Functional programming PGM 2 2110

You can set each department for:

Compulsory item validation print

If item entries must be validated, program corresponding departments for compulsory item validation print.

SICS (Single Item Cash Sale) / SIF (Single Item Finalization)

- SICS

If the first registration is to a department set for SICS, the sale is finalized as soon as the department key is pressed. If the sale is preceded by registrations to departments not set for SICS, a sale to a department set for SICS does not finalize and can be repeated until the TL key is pressed.

- SIF

Whenever a sale is made to a department set for SIF, the sale is finalized as soon as the department key is pressed.

Type of unit price entry

You may select one of the following four types of unit price entry for each department.

- Open and preset
- Preset only
- Open only
- Inhibit department key

Procedure

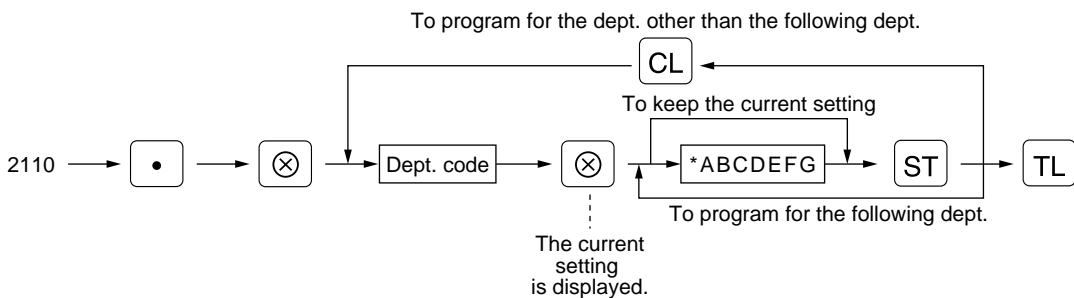

* Item:	Selection:	Entry:
A Always enter 0.		0
B Item validation print	Compulsory	1
	Non-compulsory	0
C and D Always enter 0.		0
E SIF/SICS /Normal	SIF	2
	SICS	1
	Normal	0
F Always enter 0.		0
G Type of unit price entry	Open and preset	3
	Preset only	2
	Open only	1
	Inhibit department key	0

Example

Key operation

2110 [.] [⊗]
 3 [⊗] 0000003 [ST]
 [TL]

Print

```
#2110 *PGM2X
D03          0.00
DPT.03      601
0000003     0 COL18
```

A through G

Tax status PGM 2 2111 Direct

Assign a tax status to each department. When entries are made into taxable departments in a transaction, tax is automatically computed according to the associated tax rate as soon as the transaction is completed.

Procedure

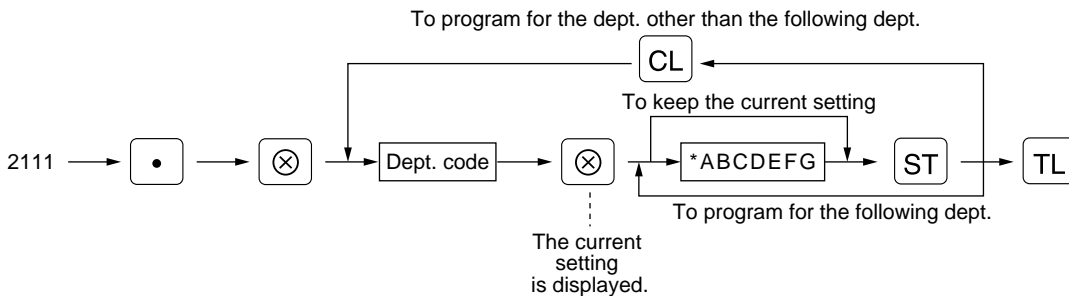

* Item:	Selection:	Entry:
A	Always enter 0.	0
B	VAT6 or TAX6	Yes
		No
C	VAT5 or TAX5	Yes
		No
D	VAT4 or TAX4	Yes
		No
E	VAT3 or TAX3	Yes
		No
F	VAT2 or TAX2	Yes
		No
G	VAT1 or TAX1	Yes
		No

Note

- The tax system of your machine has been factory-set to automatic VAT1-6. If you desire to select any of automatic tax 1-6, manual VAT1-6, manual VAT1, manual tax 1-6, and the combination of the automatic VAT 1-3 and the automatic tax 4-6, consult your dealer.
- When the combination of the automatic VAT1-3 and automatic tax 4-6 system is selected, one of the VAT1(G), VAT2(F) and VAT3(E) can be selected in combination with tax 4-6.
 Example: BCDEFG= 100100, 110100, 111010

Example

Key operation

2111
 4 0000110
 10 0000101

Print

```
#2111 *PGM2X
D04 T 23      0.00
DPT.04      G01
0000001      0 COL18
D10 T1 3      0.00
DPT.10      G01
0000001      0 COL18
```

Tax status

■ A limit amount (HALO) of entry PGM 2 2112 Direct

You can set upper limit amounts (HALO: High Amount Lockout) for each department. The limit is effective for the REG-mode operations and can be overridden in the MGR mode. HALO limit is represented by two figures as follows:

Procedure

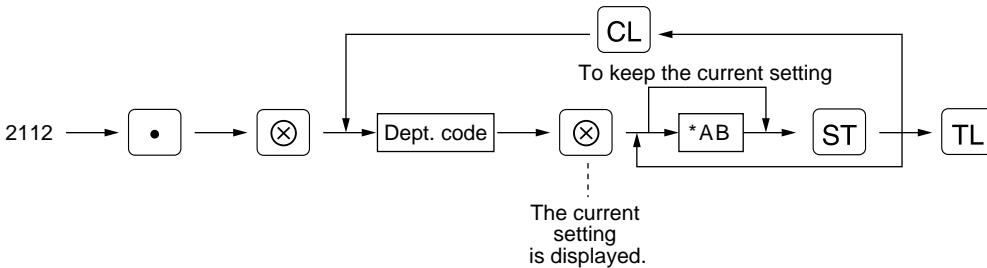

* AB is the same as $A \times 10^B$.

A: Significant digit (1 through 9)

B: Number of zeros to follow significant digit (0 through 8)

For example, presetting 14 (100.00) here means that amount entries of up to 100.00 are allowed in the REG mode. But when you preset 18, the upper limit amount is 999999.99.

Example

Key operation

2112
 1 95

Print

```
#2112 *PGM2X
D01          0.00
DPT.01      G01
0000001      0 COL95
```

HALO limit

■ Alphanumeric characters PGM 2 2114

You can program a maximum of 16 characters (item label) for each department. (However, the default setting is for a 12-character label.)

Select the characters you want to program, referring to section “2 How to program alphanumeric characters” in chapter “PRIOR TO PROGRAMMING”.

Procedure

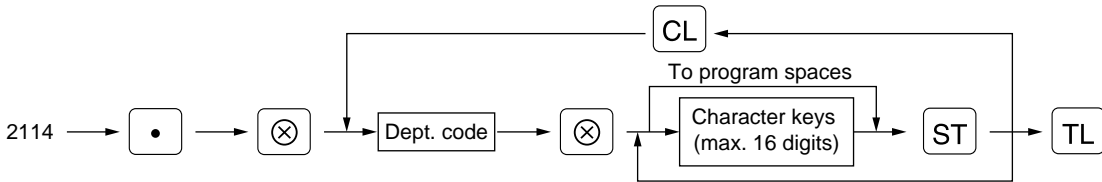

Example

Key operation

2114 • ⊗
 1 ⊗
 FRUITS ST
 TL

Print

```
#2114 #FGM2X
D01          0.00
FRUITS      G01
0000001     0 COL95
```

Label programmed for dept. 1

■ Unit price PGM 1 PGM 2 1110 Direct

You can program unit prices up to a maximum of six digits (9999.99). Even if a department is not programmed to allow the entry of preset unit prices in functional programming (job 2110), the department is automatically changed to allow the entry of preset unit prices by this programming entry.

Procedure

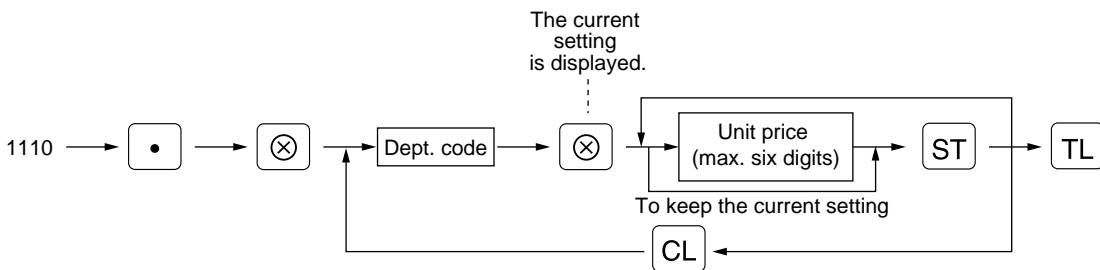

Example

Key operation

1110 • ⊗
 1 ⊗ 1000 ST
 TL

Print

```
#1110 #FGM2X
D01          10.00
FRUITS      G01
0000003     0 COL95
```

Unit price

■ Commission group assignment PGM 2 2115

Your machine allows you to assign a commission group (1-9) to each department.

Procedure

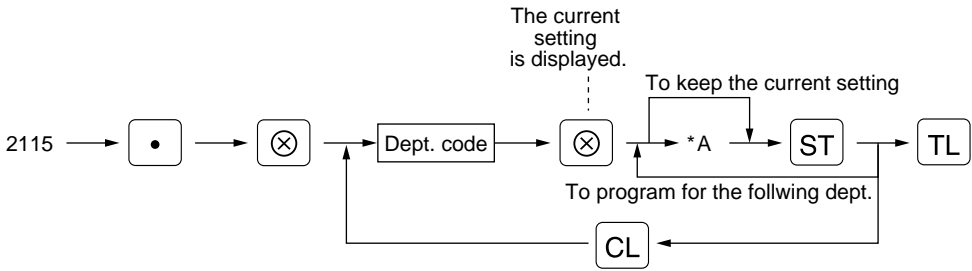

* A: Commission group 0-9 (0 = no commission)

Example

Key operation

```

2115 . ⊗
1 ⊗ 1 ST
CL 5 ⊗ 2 ST
      TL
    
```

Print

```

#2115 XPGM2X

D01          10.00
FRUITS          601
0000003      0 C1L95
D05           0.00
OPT.05         601
0000001      0 C2L18
    
```

Commission group number

■ Group number PGM 2 2116

You can assign departments to a maximum of 14 groups (1 through 14). This programming enables you to take group department sales reports.

Procedure

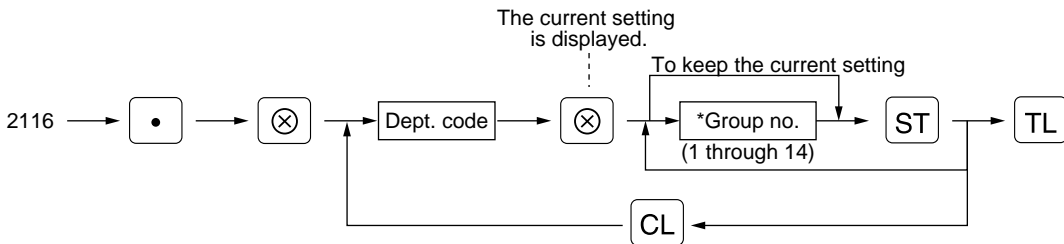

* Group number:	Dept. (+)	1 through 9 (groups 1 through 9)
	Dept. (-)	10
	Hash (+) dept.	11
	Hash (-) dept.	12
	Bottle return (+) dept.	13
	Bottle return (-) dept.	14

Note The standard model provides no hash dept./bottle return dept. If you need them, please consult your dealer.

Example

Key operation

```

2116 . ⊗
1 ⊗ 1 ST
      2 ST
          TL
    
```

Print

```

#2116 *PGM2*
D01          10.00
FRUITS      001
0000003    0 C1L95
D02          0.00
DPT.02     002
0000001    0 COL18
    
```

Group no.

■ Department key positioning PGM 2 2119

You can assign a department number to each key position. Each key position has a corresponding key number. Departments may be freely selected for the number of department keys and their positions. To assign the department to a key position, select the key number of the position. For key number position, refer to section "2 Standard key number layout" in chapter "KEYBOARD".

Procedure

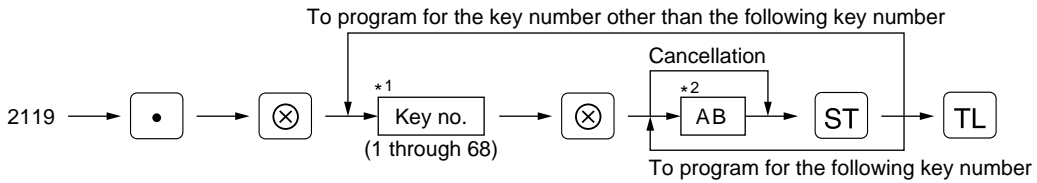

*1 The key number placement is determined by your local Authorized SHARP Dealer.

*2 AB is a department code.

Example

Key operation	Print
2119 • ⊗ 1 ⊗ 1 ST 2 ST TL	<div style="border: 1px solid black; padding: 10px; width: fit-content; margin: 0 auto;"> <pre>#2119 XPGM2X 001 D01 002 D02</pre> </div> <div style="margin-left: 20px; margin-top: 5px;"> Key no. Dept. code </div>

5 Price lookup (PLU) programming

Your machine has two kinds of PLU registration methods.

Direct PLU registration: Accomplished by depressing item key (direct PLU key) directly.

Indirect PLU registration: Accomplished by making an entry of PLU code and pressing the **PLU/SUB** key.

Each PLU requires you to program the following:

PLU code (six digits)

Associated department

When a PLU is associated with a department, the following functions of the PLU depend on the programming for the corresponding department.

- Grouping (Group 1 through 14)
- HALO (only for the subdepartment)
- Single item cash sale/Single item finalization
- Item validation print compulsory/non-compulsory

Unit price (max. six digits)

You will usually have unit prices programmed for individual PLUs as PLU preset unit prices. If you program unit price "0" for a PLU, you can enter only the selling quantity of the PLU, i.e. the PLU can be used only as a counter.

Base quantity for split-pricing entries - two digits

Program a base quantity for each PLU/subdepartment dedicated to split-pricing entries.

PLU, subdepartment, PLU/subdepartment, delete, or prohibit mode

- If the PLU mode (i.e. automatic preset unit price entry) is selected, individual PLU entries can be made by entering the assigned code and depressing the **PLU/SUB** key (or by depressing a direct PLU key without any PLU code entry).
- If the subdepartment mode is selected, the **AMT** key must be depressed after the price entry followed by the PLU code entry. The entry is finalized by the **PLU/SUB** key depressed.
- If the PLU/subdepartment mode is selected, the entries in both the PLU and subdepartment modes are available.
- If the delete mode is selected, the corresponding program data for each PLU is deleted.
- If the prohibit mode is selected, the assigned PLU code cannot be entered. This mode does not clear the PLU/subdepartment program data.

Sign (+/-)

The function of every PLU/subdepartment varies according to the combination of its sign and its associate department's sign as follows:

Sign		Function of PLU/subdepartment
Dept.	PLU/subdept.	
+	+	Serves as a normal plus PLU/subdept.
-	-	Serves as a normal minus PLU/subdept.
+	-	Accepts store coupon entries, but not split-pricing entries.
-	+	Not valid; not accepted.

Tax status

Item label (12 characters) (option: max. 16 characters)

Commission group (1 to 9)

Link PLU

Any PLU is able to link to any other PLU (e.g. bottle deposit). However, the number of links is a maximum of 5. Even if more than 5 PLUs are linked, the sixth or higher link is not actualized.

Direct PLU key positioning

Note

For some items, you can program in two ways: programming an individual PLU code and for a range of sequential PLU codes. The procedure marked "For each PLU" shows individual PLU programming. "For a range of PLUs" shows sequential range PLU programming.

Department assignment

PGM 1

PGM 2

1200

2230

Direct

Procedure

For each PLU

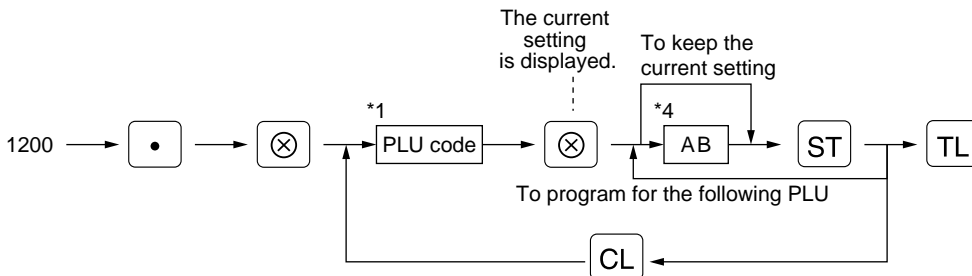

Note

As soon as the programming is completed for one PLU, the next PLU code appears in the display.

For a range of PLUs

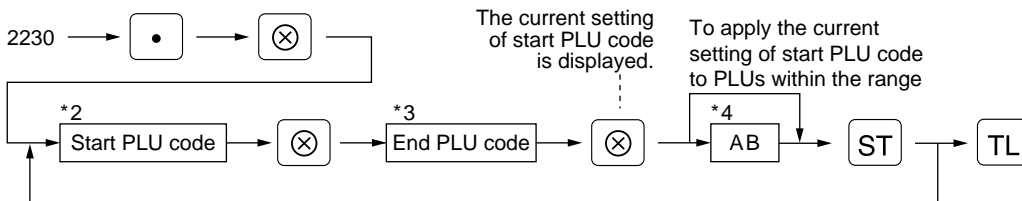

*1, 2, 3: 1 to 999999 (free code)

*4: AB: Associated department code

Example

For each PLU

Key operation

```
1200 . ⊗
1 ⊗ 2 ST
      2 ST
      TL
```

Print

```
#1200 XPGM2X
F000001(O2) /00
              0.00
PL000001      CO
002
F000002(O2) /00
              0.00
PL000002      CO
002
```

PLU code
Associated dept.

For a range of PLUs

Key operation

```
2230 . ⊗
11 ⊗ 20 ⊗
      3 ST
      TL
```

Print

```
#2230 XPGM2X
F000011 -F000020
(O3)
```

PLU range
Associated dept.

■ **Unit prices** PGM 1 PGM 2 **1210** Direct

Procedure

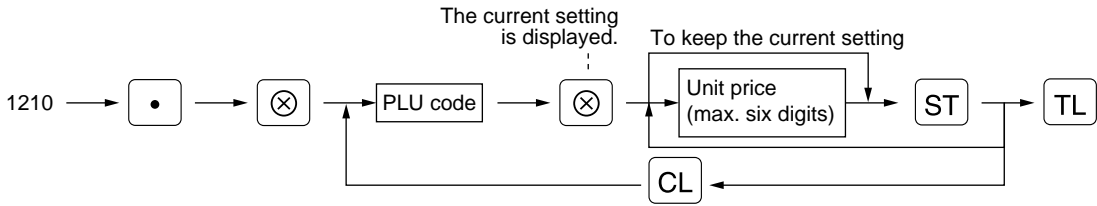

Example

Key operation

1210 • ⊗
 1 ⊗ 125 ST
 TL

Print

```
#1210 *PGM2*
F000001(O2) /00
                1.25 Unit price
PL000001      CO
002
```

■ **Base quantity** PGM 1 PGM 2 **1211**

Procedure

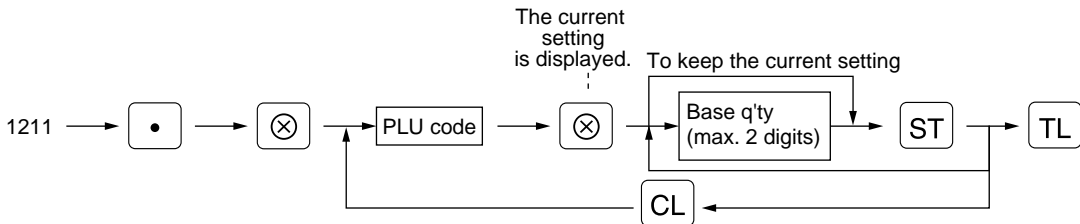

Example

Key operation

1211 • ⊗
 2 ⊗ 12 ST
 TL

Print

```
#1211 *PGM2*
F000002(O2) /12
                0.00 Base q'ty
PL000002      CO
002
```

PLU/subdepartment mode PGM 2 2210 2231 Direct

Procedure

For each PLU

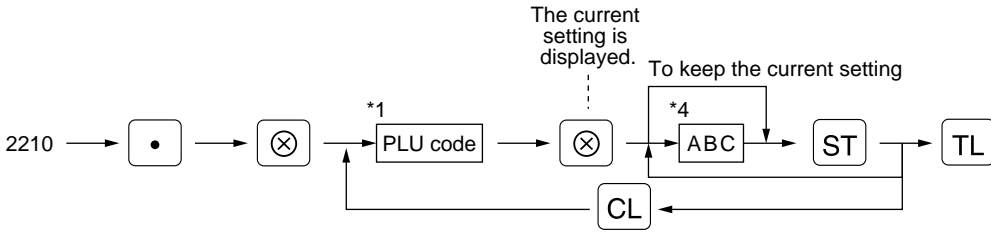

For a range of PLUs

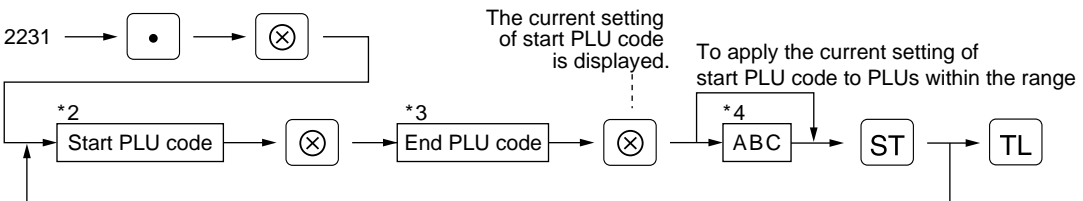

*1,2,3: 1 through 999999

*4: Item:	Selection:	Entry:
A and B	Always enter 0.	0
C	Mode parameter	
	Prohibit mode	0
	Subdept. mode	1
	PLU mode	2
	PLU/subdept. mode	3
	Delete mode	4

Example

For each PLU

Key operation

2210 [dot] [x]
 1 [x] 003 [ST]
 [TL]

Print

```
#2210 #PGM2X

F000001(02) /00
              1.25
PL000001    CO
003
```

3: PLU/subdept. mode

For a range of PLUs

Key operation

2231 [dot] [x]
 11 [x] 20 [x]
 003 [ST]
 [TL]

Print

```
#2231 #PGM2X

F000011 -F000020
003
```

PLU range
 3: PLU/subdept. mode

Procedure

For each PLU

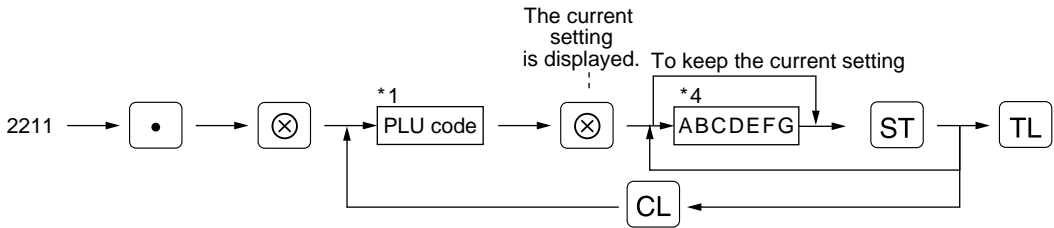

For a range of PLUs

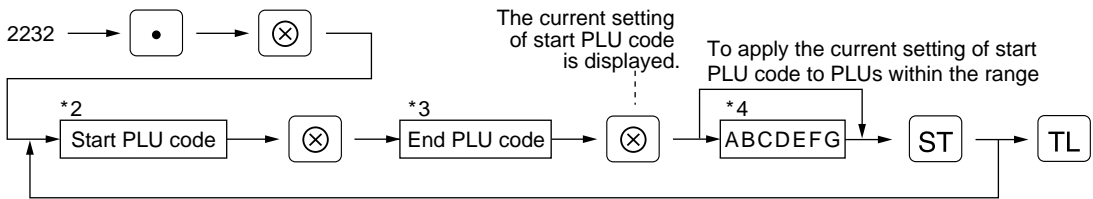

*1,2,3: 1 through 999999

*4: Item:	Selection:	Entry:
A Sign (+/-)	Minus PLU	1
	Plus PLU	0
B VAT6 or TAX6	Yes	1
	No	0
C VAT5 or TAX5	Yes	1
	No	0
D VAT4 or TAX4	Yes	1
	No	0
E VAT3 or TAX3	Yes	1
	No	0
F VAT2 or TAX2	Yes	1
	No	0
G VAT1 or TAX1	Yes	1
	No	0

- Note**
- The tax system of your machine has been factory-set to automatic VAT1-6. If you desire to select any of automatic tax 1-6, manual VAT1-6, manual VAT1, manual tax 1-6, and the combination of the automatic VAT 1-3 and the automatic tax 4-6, consult your dealer.
 - When the combination of the automatic VAT1-3 and automatic tax 4-6 system is selected, one of the VAT1(G), VAT2(F) and VAT3(E) can be selected in combination with tax 4-6.
Example: BCDEFG= 100100, 110100, 111010
 - A PLU not programmed for any of these tax statuses is registered depending on the tax status of the department which the PLU belongs to.

Example

For each PLU

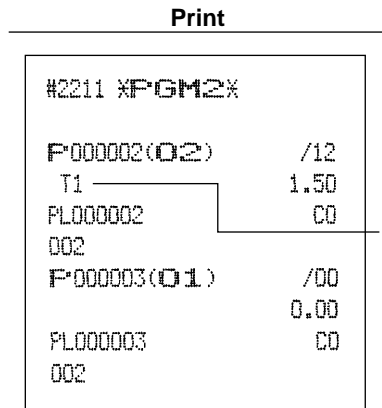
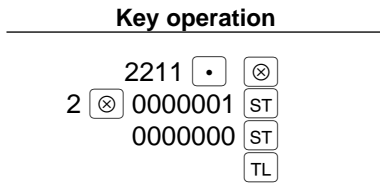

For a range of PLUs

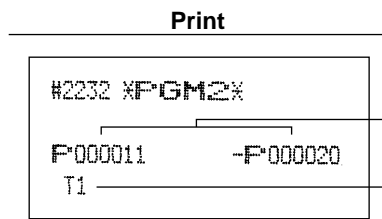
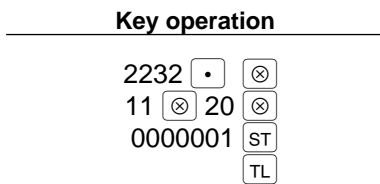

Alphanumeric characters PGM 2 2214

You can program a maximum of 16 characters (item label) for each PLU or subdepartment. (However, the default setting is for a 12-character label.) Select the characters you want to program, referring to section “2 How to program alphanumeric characters” in chapter “PRIOR TO PROGRAMMING”.

Procedure

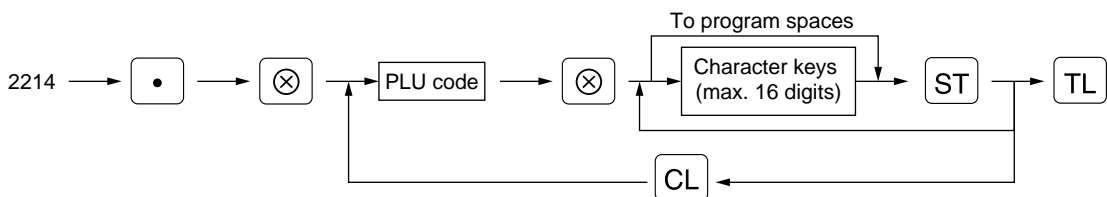

Example

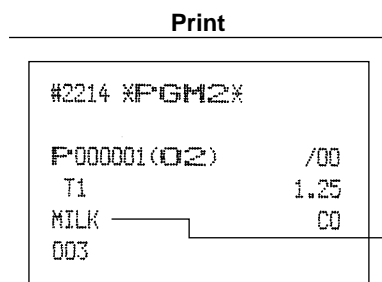
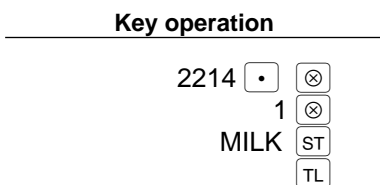

■ Assigning of PLUs to commission groups PGM 2 2215 2235

You can assign PLUs (or subdepartments) to commission groups.

Procedure

For each PLU

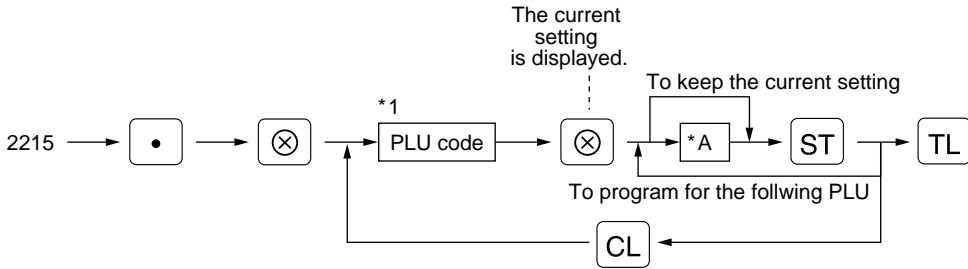

For a range of PLUs

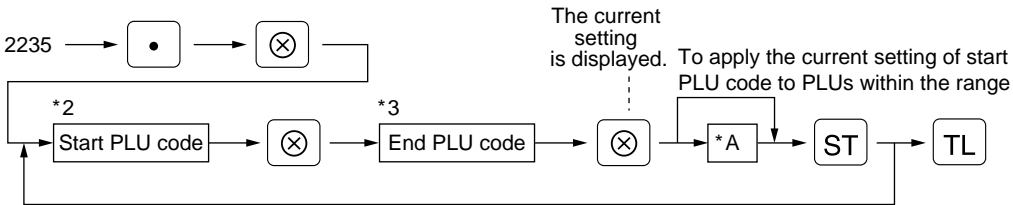

*1,2,3 : 1 through 999999

*A : Commission group 0-9 (0=no commission)

Example

For each PLU

Key operation

2215 . ⊗
1 ⊗ 1 ST
TL

Print

```
#2215 *PGM2X
P000001(O2) /00
T1 1.25
MILK C1
003
```

Commission group number

For a range of PLUs

Key operation

2235 . ⊗
12 ⊗ 14 ⊗
1 ST
TL

Print

```
#2235 *PGM2X
P000012 -P000014
C1
```

PLU range

Commission group number

■ Link PLU PGM 2 2220

Procedure

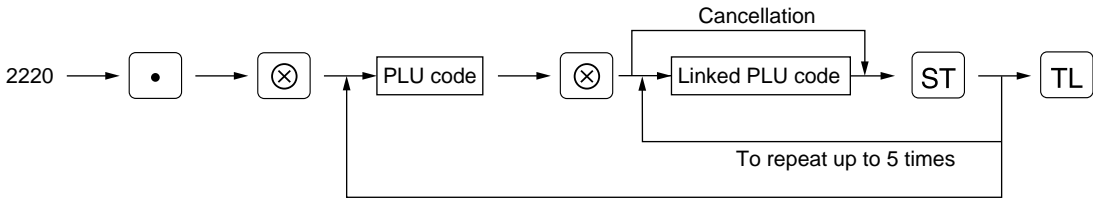

- Note**
- To program this function, please consult your dealer.
 - PLU codes must have already been defined.

Example

Key operation

2220 • ⊗
 21 ⊗ 25 ST
 26 ST
 27 ST
 TL

Print

```
#2220 XPGM2X
P000021      LP000025
              P000026
              P000027
```

Linked
PLU code

■ Direct PLU key positioning PGM 2 2219

You can assign a PLU code to each key position. PLUs may be selected for the number of direct PLU keys and their positions. For key number positions, refer to section "2 Standard key number layout" in the chapter "KEYBOARD".

Procedure

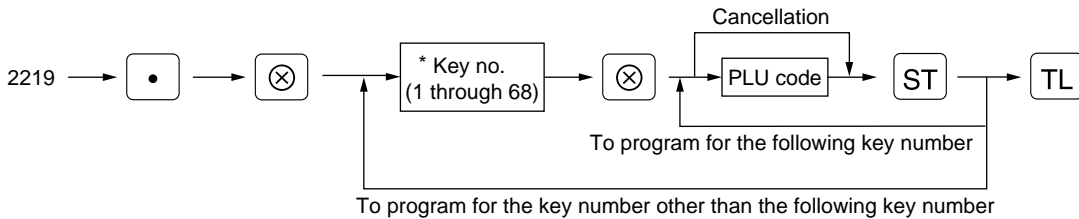

* The key number placement is determined by your local Authorized SHARP Dealer.

Example

Key operation

2219 • ⊗
 16 ⊗
 1 ST
 TL

Print

```
#2219 XPGM2X
016          P000001
```

Key no.
PLU code

6 European Article Number (EAN) or Universal Product Code (UPC) programming

■ EAN or UPC code

Your machine can transact the following codes:

- UPC-A (Number system character: 0, 2, 3, 4)
- UPC-E
- EAN-8
- EAN-13

For the codes used in-store marking, there are two types of PLU type (treated as a code like PLU code) and Non-PLU type (price/quantity information is included in the code).

When a code is non-PLU type, the price/quantity in the code is read for sales entry (in case of quantity, "quantity multiplies preset unit price" is processed to obtain price.)

UPC-A

- Number system character: 0 <used in the source marking>
- Number system character: 3 <used as NDC or HRI>

For entry, a full 12 digits number or 11 digits number (omitting the check digit) must be entered.

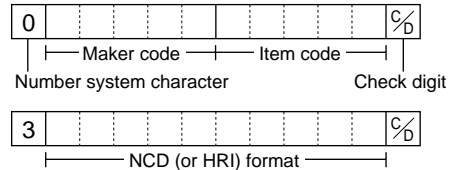

- Number system character: 2 <In-store marking Non-PLU type>
You can program the format by the job #2025.
- Number system character: 4 <In-store marking PLU type>

For entry, a full 12 digits number, 11 digits number (omitting the check digit), or a leading zero plus 12 digits number must be entered. (Any numbers are allowed for the digits marked with *, and on the receipt/journal, non-PLU type code is printed like 202008**** (****: price information).)

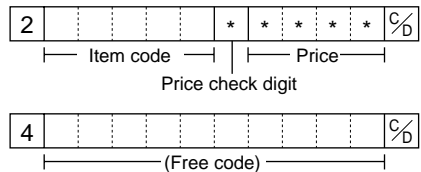

UPC-E

- UPC-E is a zero-suppressed version of UPC-A that conforms to the UPC-E Standards. This code is used for marking small package.

For entry, a 6 digits number or a leading zero plus 6 digits number must be entered.

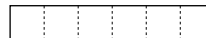

EAN 8

- Ordinary EAN-8 code (flag: neither 0 nor 2) <used in the source marking>

For entry, a full 8 digits number must be entered.

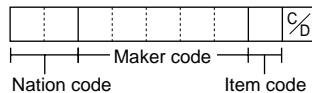

- Internal code (flag 2) <in-store marking non-PLU short type>
Program the format by the job #2025.
- Internal code (flag 0) <in-store marking PLU short type>

For entry, a full 8 digits number must be entered. On the receipt/journal, non-PLU type code is printed like 208**** (****: price/quantity information)

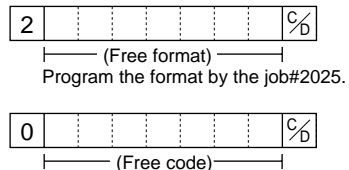

■ Add-on code

UPC-A and EAN-13 may be followed by a two digits number or a five digits number as add-on code, excepting UPC-A without a check digit plus two or five digits add-on code.

Therefore, the total number of digits enterable for sales entries are as shown below:

Code entry	No add-on code	2-digit add-on code	5-digit add-on code
UPC-A	12	14	17
UPC-A w/leading zero	13	15	18
UPC-A w/o check digit	11	–	–
UPC-E	6	–	–
EAN-8	8	–	–
EAN-13	13	15	18

Note

Your register automatically judge the add-on code in an EAN code entered from the total number of digits and the flag.

■ EAN/UPC programming

Each EAN or UPC (hereinafter referred to as EAN) requires you to program the following.

- **EAN code (max. 13 digits)**
- **Associated department (1-50)**

When an EAN is associated with a department, the following functions of the EAN depend on the programming for the department.

- Grouping (Group 1 through 14)
- HALO (only for the subdepartment)
- Single item cash sale/Single item finalization
- Item validation print compulsory/non-compulsory

EAN code delete method

You can program how you delete EAN codes; deleting in the programming, inhibit deleting, or deleting the EAN codes that have not been accessed for a certain period, which can be programmed (up to 99 days) when you execute #105 in Z1 mode.

Unit price (max. six digits)

Base quantity for split-pricing entries

Sign (+/-)

Tax status

If you do not program tax status for a EAN, the tax status of the EAN follows to the status of the associated department.

Item label (12 characters) (option max. 16 characters)

Commission group (1-9)

EAN link

System programming for EAN function

Delete period for non-accessed EAN codes

Non-PLU code format

Type of press code

Price entry method for press code

Label of record in EAN file

Department assignment PGM 1 PGM 2 **1000** Direct

Procedure

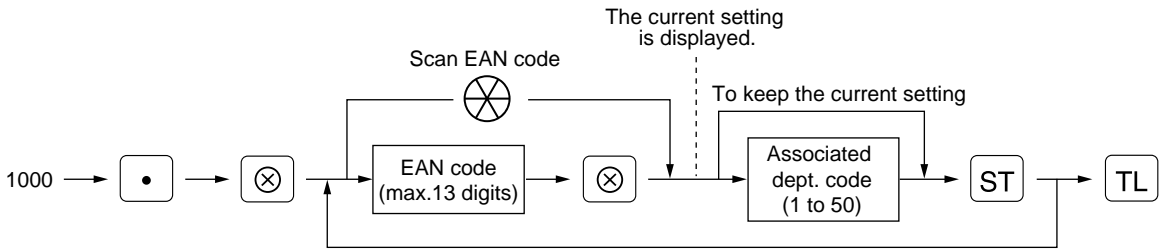

Example

Key operation

1000 . ⊗
 5012345678900 ⊗
 2 ST
 TL

Print

```
#1000 *PGM2*
5012345678900# (02)/00
                0.00
                00
```

— EAN code
 — Associated dept.

Unit prices PGM 1 PGM 2 **1010** Direct

Procedure

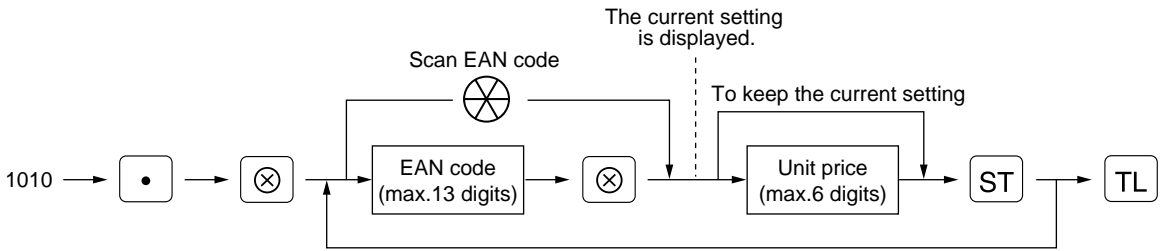

Example

Key operation

1010 . ⊗
 5012345678900 ⊗
 250 ST
 TL

Print

```
#1010 XPGM2X
5012345678900# (02)/00
                2.50
                00
```

Unit price

Base quantity PGM 1 PGM 2 **1011**

Procedure

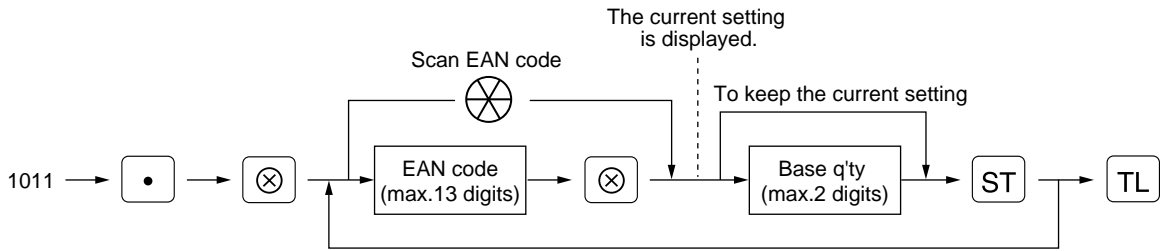

Example

Key operation

1011 . ⊗
 5012345678900 ⊗
 5 ST
 TL

Print

```
#1011 XPGM2X
5012345678900# (02)/05
                2.50
                00
```

Base q'ty

Delete method PGM 2 2010

Procedure

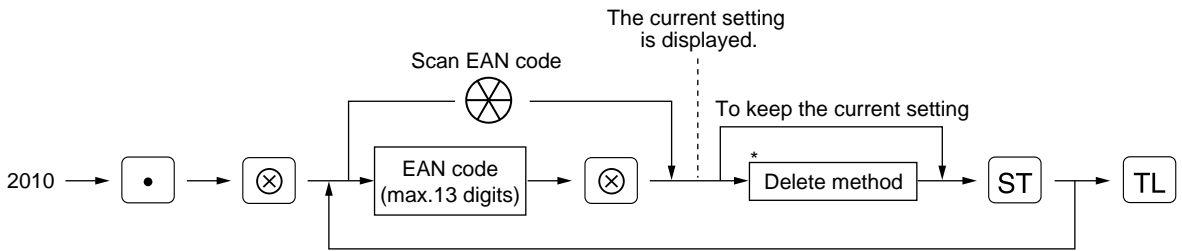

*** Delete method**

4: Delete now

1: Inhibit to delete in non-accessed EAN deleting job (#105 in Z1 mode)

0: Delete in non-accessed EAN deleting job (#105 in Z1 mode)

With the execution of <None> EAN deleting job, you can delete EANs that has not been accessed during the period that is programmed in the job #2029.

Example

Key operation

2010 . ⊗
 5012345678900 ⊗
 1 ST
TL

Print

```
#2010 *PGM2*
5012345678900# (02)/05
⊗ 2.50
  00
```

Delete method
 (Inhibit to delete by job#105 in Z1 mode)
 In case of "delete", no mark is printed.

When "delete now" is selected:

```
#2010 *PGM2*
5012345678900# ----
```

Procedure

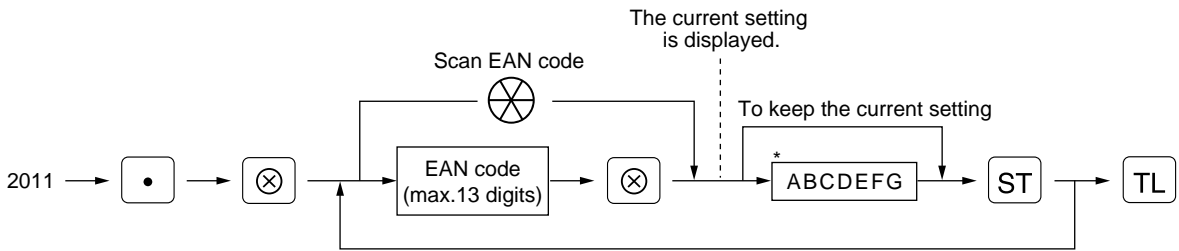

Item:	Selection:	Entry:
A Sign (+/-)	Minus PLU	1
	Plus PLU	0
B VAT6 or TAX6	Yes	1
	No	0
C VAT5 or TAX5	Yes	1
	No	0
D VAT4 or TAX4	Yes	1
	No	0
E VAT3 or TAX3	Yes	1
	No	0
F VAT2 or TAX2	Yes	1
	No	0
G VAT1 or TAX1	Yes	1
	No	0

- Note**
- The tax system of your machine has been factory-set to automatic VAT1-6. If you desire to select any of automatic tax 1-6, manual VAT1-6, manual VAT1, manual tax 1-6, and the combination of the automatic VAT 1-3 and the automatic tax 4-6, consult your dealer.
 - When the combination of the automatic VAT1-3 and automatic tax 4-6 system is selected, one of the VAT1(G), VAT2(F) and VAT3(E) can be selected in combination with tax 4-6. Example: BCDEFG= 100100, 110100, 111010
 - An EAN not programmed for any of these tax statuses is registered depending on the tax status of the department which the EAN belongs to.

Example

Key operation	Print
2011 <input type="checkbox"/> <input type="checkbox"/> 5012345678900 <input type="checkbox"/> 0000001 <input type="checkbox"/> <input type="checkbox"/> <input type="checkbox"/>	<pre>#2011 *PGM2* 5012345678900# (02)/05 *<u>T1</u> 2.50 00</pre>
	Taxable 1

■ Alphanumeric characters PGM 2 2014

You can program a maximum of 16 characters (item label) for each EAN. (However, the default setting is for a 12-character label.) Select the characters you want to program, referring to section “2 How to program alphanumeric characters” in chapter “PRIOR TO PROGRAMMING”.

Procedure

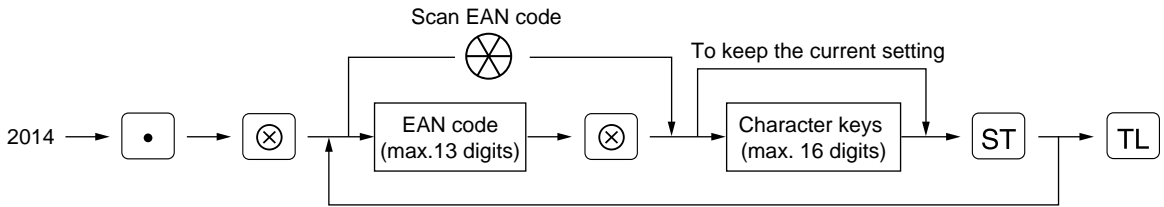

Example

Key operation

2014 • ⊗
 5012345678900 ⊗
 APPLE ST
 TL

Print

```
#2014 *PGM2*
5012345678900# (02)/05
*ET1 2.50
APPLE CO
```

└── Item label

■ Assigning of EANs to commission groups PGM 2 2015

You can assign EANs to commission groups.

Procedure

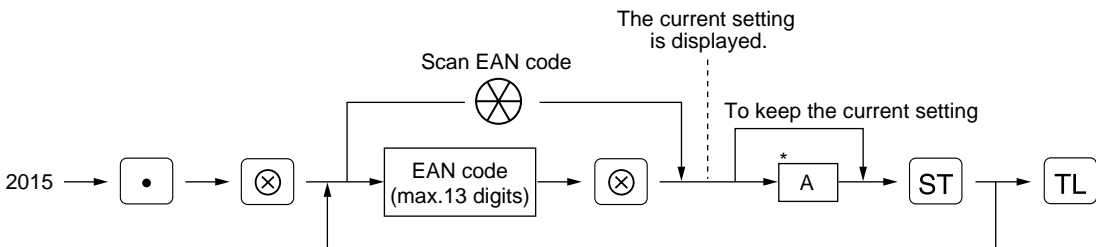

*A : Commission group 0-9 (0=no commission)

Example

Key operation

2015 • ⊗
 5012345678900 ⊗
 1 ST
 TL

Print

```
#2015 *PGM2*
5012345678900# (02)/05
*ET1 2.50
APPLE C1
```

└── Commission group number

■ EAN link PGM 2 2030

Procedure

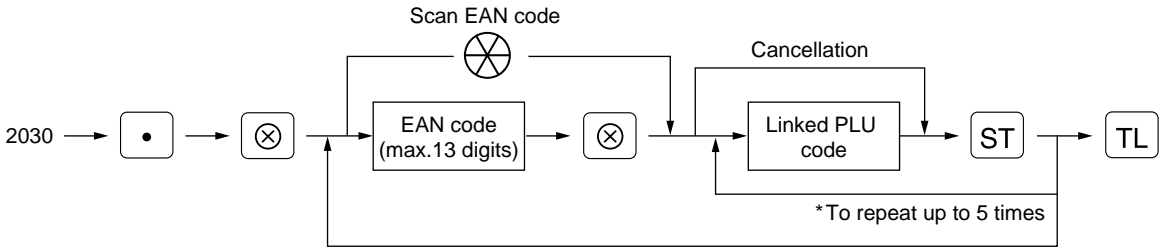

* The programmed number of link PLUs is shown on the display like "P1". (Incremented one every time you program a linked PLU.)

- Note**
- To program this function, please consult your dealer.
 - EAN code and PLU code must have been already defined.

Example

Key operation	Print
2030 . ⊗ 5012345678900 ⊗ 30 ST 31 ST 32 ST TL	<pre style="font-family: monospace; font-size: 0.9em;"> #2030 XPGM2X 5012345678900#L P000030 P000031 P000032 </pre> <div style="text-align: right; margin-top: -10px;"> Linked PLU </div>

■ Delete period for non-accessed EAN codes PGM 2 2029

You can delete the EAN codes which have not been accessed during the period you set in this program when you execute the job #105 in Z1 mode when you set "Delete in X/Z non-accessed EAN deleting job" in the EAN delete method (#2010).

Procedure

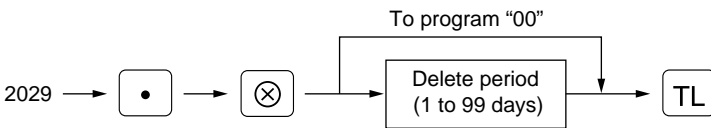

* When you select "00" for the period, no EAN code is deleted by the X/Z non-accessed EAN deleting job even if you programmed "Delete in X/Z non-accessed EAN deleting job" in the job #2010.

Example

Key operation	Print
2029 . ⊗ 60 TL	<pre style="font-family: monospace; font-size: 0.9em;"> #2029 XPGM2X #2029 60 </pre>

■ Programming Non-PLU code format PGM 2 2025

The register allows you to specify the Non-PLU code format (flag code: 2, 02, 20 -29).
The format data is as follows:

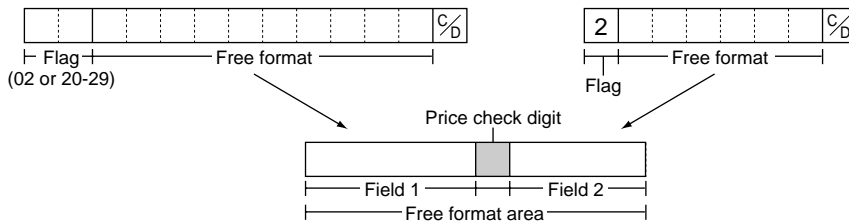

Procedure

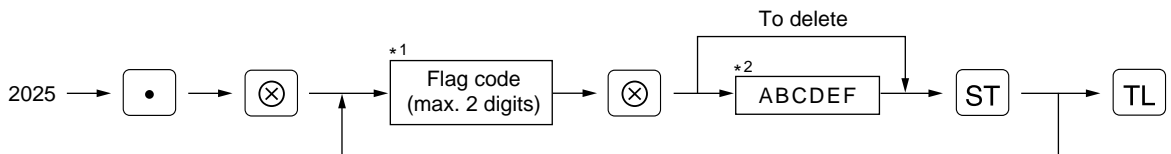

*1 Flag code: 2, 02, 20 - 29

*2 Item:	Selection:	Entry:
A	Length of field 1 (number of digits)	0 - 9
B	Length of field 2 (number of digits)	0 - 9
C	Meaning of field 1*3	Free code
		Dept. code
		PLU code
D	Meaning of field 2*4	Quantity
		Price
		0
E	Price check digit used	Yes
		No
F	TAB or decimal point of field 2 (0, 1, 2, 3)	0 - 3

*3: When you select Dept. code, the sales are counted up as the sales of the department (associated department assignment is ignored.), and when you select PLU code, the sales are counted up as the sales of the PLU code, while they are counted up as EAN sales for sales reports.

*4: When you select quantity, the sales amount is calculated as follows: quantity x unit price programmed in #1010.

Example

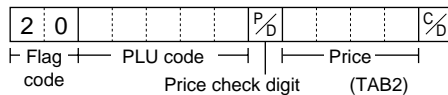

Key operation

2025
 20
 540012

Print

```
#2025 XPGM2X
20      5 4 0 0 1 2 —ABCDEF
|
Flag code
```

Press code functional programming PGM 2 2035

Procedure

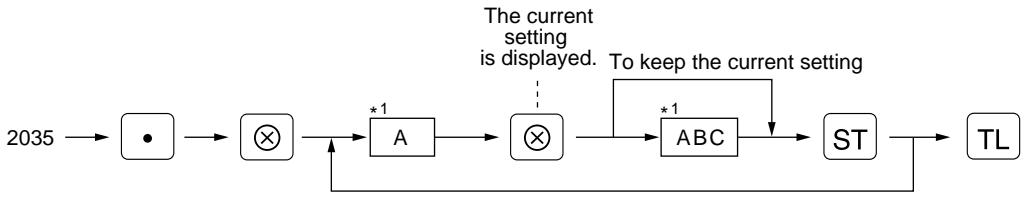

- *1 Type of prefix code
 1: German type 1 (prefix code: 434/439)
 2: U.K. (prefix code: 988/989)
 3: French (prefix code: 378/379)
 4: Sweden (prefix code: 7388)
 5: German type 2 (prefix code: 414/419)

*2 Item:	Selection:	Entry:
A Type of code	Normal EAN code	0
	Press code	1
B Price entry method for press code*3	Using the encoded price	0
	Using the EAN programmed price in the job #1010	1
	Compulsory	2
C Label of record in EAN file*3*4	Prefix only	0
	Prefix + article code	1

- *3: This setting is valid only when "press code" is set for item A.
 *4: Select "prefix only" when you want to summarize the sales of items having press codes by category.
 Select "prefix + article code" when you want to summarize the sales of items having press codes by each item.

Example

Key operation

```

2035 . ⊗
      1 ⊗
      111 ST
           TL
    
```

Print

```

#2035 *FGM2*
┌───────────┬───────────┐
│ 1           │           111 │
└───────────┴───────────┘
    
```

Type of prefix code
ABC

7 Programming for miscellaneous keys

Only function keys which you have programmed on the keyboard will allow the programming.

■ Programming the rate (% , EX, commission) and the deduction (⊖) PGM 1

PGM 2 1310 Direct

You can program percent rates, currency exchange rates, deduction amounts and commission rates.

Procedure

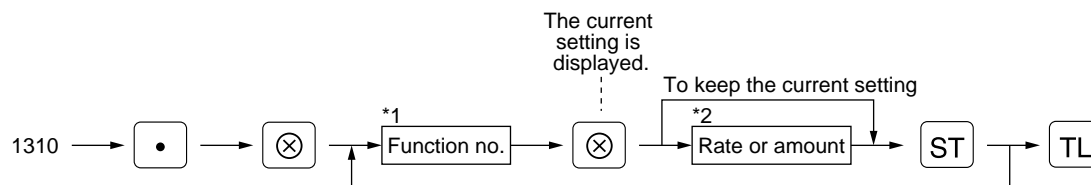

*1: Function no.

- | | | |
|-------------------|-------------------------------|-------------------------------|
| 1: For the ⊖ key | 8: For the %4 key | 78: For the commission sale 4 |
| 2: For the ⊖2 key | 52: For the EX1 key | 79: For the commission sale 5 |
| 3: For the ⊖3 key | 53: For the EX2 key | 80: For the commission sale 6 |
| 4: For the ⊖4 key | 54: For the EX3 key | 81: For the commission sale 7 |
| 5: For the %1 key | 75: For the commission sale 1 | 82: For the commission sale 8 |
| 6: For the %2 key | 76: For the commission sale 2 | 83: For the commission sale 9 |
| 7: For the %3 key | 77: For the commission sale 3 | |

*2: Rate or amount

- 0 — 999999 (Deduction amount)
- 0.00 — 100.00 (% rate)
- 0.000000 — 999.999999 (Currency exchange rate)
- 0.00 — 999.99 (Commission rate)

Note

- When you introduce EURO, set the EURO conversion rate on the EX1 key for the period 1 and the period 2.
- You must use a decimal point when setting percentage rates that are fractional.

Example

Key operation

```

1310 . ⊗
1 ⊗ 1000 ST
5 ⊗ 10 . 25 ST
52 ⊗ 0 . 6068 ST
TL
    
```

Print

```

#1310 *PGM2X

F001 (-) 1
S          -10.00 — Deduction amount
                L18

F005 %1
S          -10.25% — Percent rate
                L100.00%

F052 EXCH1
        2          0.606800 — Currency exchange rate
    
```

■ Programming the number of digits after decimal point for exchange keys

PGM 2 **2330**

Note When you introduce EURO on your register, this setting for the **EX1** is automatically programmed by execution of Job #800.

Procedure

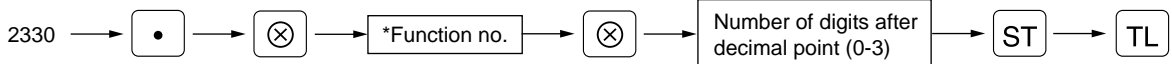

*: Function no.

52: For the **EX1** key 54: For the **EX3** key
 53: For the **EX2** key 55: For the **EX4** key

Example

Key operation

2330 [.] [⊗]
 52 [⊗]
 2 [ST]
 [TL]

Print

```
#2330 *PGM2*
F052 EXCH1
      2      0.606800
```

Number of digits after decimal point

■ Currency description text programming PGM 2 **2334**

You can program a maximum of 4 characters for each of the **EX1** through **EX4** keys.

Procedure

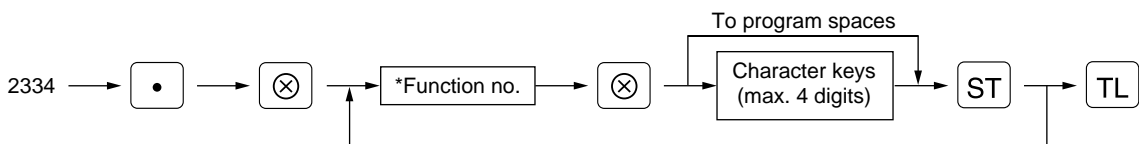

*: Function no.

52: For the **EX1** key 54: For the **EX3** key
 53: For the **EX2** key 55: For the **EX4** key

Example

Key operation

2334 [.] [⊗]
 52 [⊗]
 [SPACE] [SPACE] DM [ST]
 [TL]

Print

```
#2334 *PGM2*
F052 EXCH1      DM
      2      0.606800
```

Currency description text

■ Assigning the drawer number to the drawer for foreign currency PGM 2 **2680**

You can assign a number of the drawer which opens when one of the following operations is performed.

- One of **EX1** through **EX4** is pressed without any entry.
- A transaction is completed with a payment entry of foreign currency.
- An X/Z report is issued.

Procedure

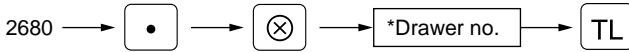

*Drawer no.:

0: Inhibit (No drawer opens.)

1: Drawer no. 1

2: Drawer no. 2

Example

Key operation

2680 [•] [⊗]
2 [TL]

Print

```
#2680 XFGM2X
2
```

Note To perform this programming, an optional drawer must be connected with your register.

■ A limit amount (HALO) of entry (**⊖**, **RA**, **PO**) PGM 2 **2312** **Direct**

The HALO limit is in effect for the REG-mode operations but can be overridden in the MGR mode. The HALO limit is represented by two figures as follows:

Procedure

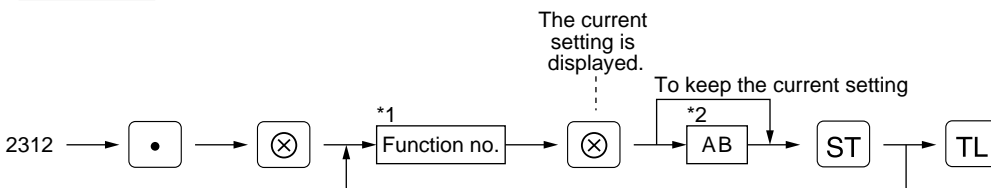

*1: Function no.

- | | |
|--------------------------|----------------------------|
| 1: For the ⊖ key | 37: For the RA key |
| 2: For the ⊖2 key | 38: For the RA2 key |
| 3: For the ⊖3 key | 39: For the PO key |
| 4: For the ⊖4 key | 40: For the PO2 key |

*2: AB is the same as A x 10^B.

A: Significant digit (0 through 9)

B: Number of zeros to follow significant digit (0 through 8)

For example, presetting 13 (10.00) here means that amount entries of up to 10.00 are allowed in the REG mode. When you press 18, however, the upper limit amount is 999999.99.

Example

Key operation

2312 . ⊗
 1 ⊗ 13 ST
 TL

Print

```
#2312 XPGM2X
F001 (-) 1
S -10.00
L13 HALO limit
```

■ +/- sign (% , ⊖) PGM 2 2311 Direct

Programming of the +/- sign assigns the premium or discount function for each key.

Procedure

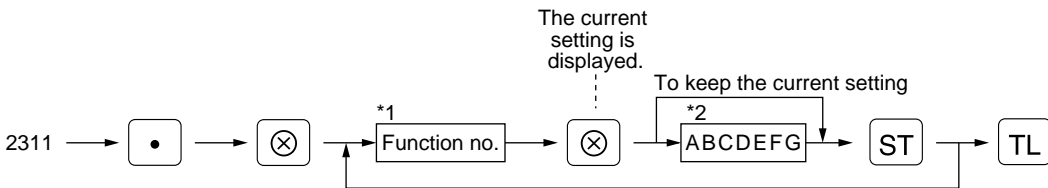

*1: Function no.

- 1: For the ⊖ key
- 2: For the ⊖2 key
- 3: For the ⊖3 key
- 4: For the ⊖4 key
- 5: For the %1 key
- 6: For the %2 key
- 7: For the %3 key
- 8: For the %4 key

*2:

Item:	Selection:	Entry:
A +/- sign	+ (premium) sign	0
	- (discount) sign	1
B to G Always enter 0.		0

Example

Key operation

2311 . ⊗
 5 ⊗ 000000 ST
 6 ⊗ 100000 ST
 TL

Print

```
#2311 XPGM2X
F005 %1
S 10.25%
L100.00%
F006 %2
S -15.00%
L100.00%
-": Discount
```

Item % or subtotal % selection (⊗) PGM 2 2315

Item %

Select this when a percent calculation is desired for the individual department and PLU.

Subtotal %

Select this when a percent calculation is desired for subtotals.

Procedure

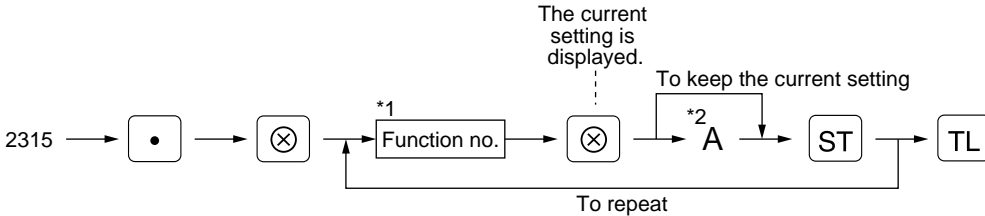

*1: Function no.

- 5: For the key
- 6: For the key
- 7: For the key
- 8: For the key

*2: A

- 0: Subtotal %
- 1: Item %

Example

Key operation

```
2315 • ⊗
5 ⊗ 1 ST
6 ⊗ 0 ST
TL
```

Print

```
#2315 XPGM2X
-----
F005 %1
I                10.25%
                  L100.00%
-----
F006 %2
S                -15.00%
                  L100.00%
```

Item %

Subtotal %

Percent rate limitation (⊗) PGM 2 2313

You can program the upper limit of percent rates for percent entries.

(Percent entries that exceed the upper limit may be overridden in the MGR mode.)

Procedure

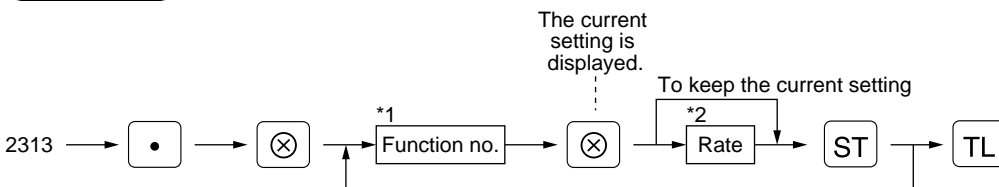

*1: Function no.

- 5: For the key
- 6: For the key
- 7: For the key
- 8: For the key

*2: Rate

- 0.00 – 100.00 (Entering 0.00 inhibits the open percent rate entry.)

Note 10.00% can be entered as or . The key is needed only for fractional entry.

Example

Key operation

2313
 5 15 00

Print

```
#2313 *PGM2*
F005 2:1
I                10.25%
L 15.00%
```

Percentage limit

Item ⊖ or subtotal ⊖ selection (⊖) PGM 2 2316

Item ⊖

Select this when a deduction calculation is desired for the individual department and PLU.

Subtotal ⊖

Select this when a deduction calculation is desired for subtotals.

Procedure

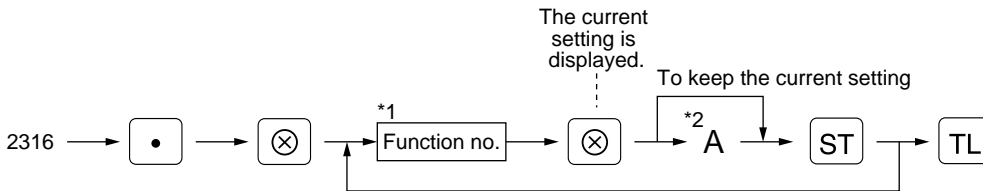

*1: Function no.

- 1: For the ⊖ key
- 2: For the ⊖2 key
- 3: For the ⊖3 key
- 4: For the ⊖4 key

*2: A

- 0: Subtotal ⊖
- 1: Item ⊖

Example

Key operation

2316
 1 1
 2 0

Print

```
*PGM2*
F001 (-)1
I                -10.00
L13
F002 (-)2
S                -0.00
L18
```

Item ⊖

Subtotal ⊖

8 Programming for the TL, CA2, CH1 through CH4, and CR1 through CR4 keys

■ Functional programming PGM 2 2320

You can set each media for:

Footer printing

This programming decides whether or not your machine should print a message at the foot of a receipt when a specified media key is used.

Non-add code compulsory

You can enforce the non-add code entry when a media entry is accepted.

Change enable (over-tender)

Either change enable or disable can be selected for a corresponding media key.

Compulsory validation print

If media entries must be validated, set the corresponding media for compulsory validation print.

Drawer open

You can program each media key to or not to open the drawer.

Amount tendered compulsory

You may select amount tendered compulsory or optional for the TL, CA2 and CH1 through CH4 keys.

You may select amount tendered compulsory or inhibited for the CR1 through CR4 keys.

Procedure

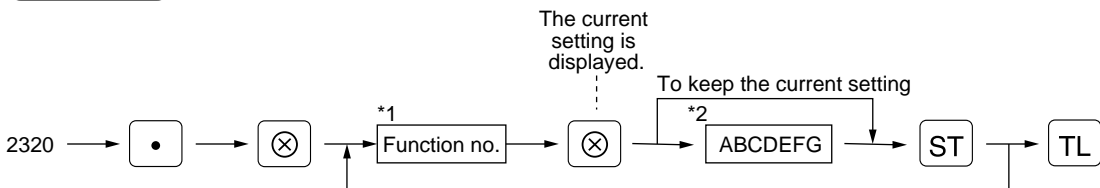

*1: Function no.

42: For the TL key

43: For the CA2 key

44: For the CH1 key

45: For the CH2 key

46: For the CH3 key

47: For the CH4 key

48: For the CR1 key

49: For the CR2 key

50: For the CR3 key

51: For the CR4 key

*2 Item:	Selection:	Entry:
A Always enter 0.		0
B Footer print	Yes	1
	No	0
C Non-add code	Compulsory	1
	Non-compulsory	0
D Change due	Disable	1
	Enable	0
E Validation print	Compulsory	1
	Non-compulsory	0
F Drawer open	No	1
	Yes	0
G Amount tendered entry	Compulsory	1
	Non-compulsory for TL, CA2 or CH1 through CH4 keys	0
	Inhibit for the CR1 through CR4 keys	0

Example

Key operation

2320 [.] [⊗]
 50 [⊗] 0000001 [ST]
 [TL]

Print

```
#2320 XPGM2X
F050 CREDIT3      L18
                   0000001
```

A through G

High amount lockout (HALO) for cheque change, cheque cashing, and cash in drawer PGM 2 **2321**

You can program the upper limit amounts for cheque change, cheque cashing, and cash in drawer.

Procedure

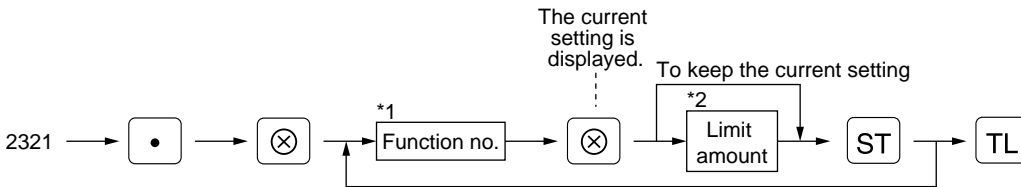

*1: Function no.

- 41: For cheque cashing
- 66: For cheque change
- 63: For cash in drawer (Sentinel)

*2: Limit amount

- 0 through 999999.99
- (Cheque change and cheque cashing)
- 0 through 9999999.99 (Cash in drawer)

Example

Key operation

2321 [.] [⊗]
 41 [⊗] 9999 [ST]
 [TL]

Print

```
#2321 XPGM2X
F041 CA/CHK
                   99.99
```

HALO limit

■ List of function texts

Function no.	Key or function	Default setting	Function no.	Key or function	Default setting
1	⊖ 1	(-)1	48	Credit 1	CREDIT1
2	⊖ 2	(-)2	49	Credit 2	CREDIT2
3	⊖ 3	(-)3	50	Credit 3	CREDIT3
4	⊖ 4	(-)4	51	Credit 4	CREDIT4
5	%1	%1	52	Exchange 1	EXCH1
6	%2	%2	53	Exchange 2	EXCH2
7	%3	%3	54	Exchange 3	EXCH3
8	%4	%4	55	Exchange 4	EXCH4
9	Differ	DIFFER	56	Exchange 1 is	EXCH1 IS
10	Taxable 1 subtotal	TAX1 ST	57	Exchange 2 is	EXCH2 IS
11	Taxable 2 subtotal	TAX2 ST	58	Exchange 3 is	EXCH3 IS
12	Taxable 3 subtotal	TAX3 ST	59	EX1 check sale	EX1 CHK
13	Taxable 4 subtotal	TAX4 ST	60	Domestic currency for EX1 check sale	DOM.CUR1
14	Taxable 5 subtotal	TAX5 ST	61	EX1 credit sale	EX1 CR.
15	Taxable 6 subtotal	TAX6 ST	62	Domestic currency for EX1 credit sale	DOM. CUR
16	VAT/tax 1	VAT 1	63	Cash in drawer	**** CID
17	VAT/tax 2	VAT 2	64	Cash/cheque is	CA/CH IS
18	VAT/tax 3	VAT 3	65	Cash/cheque in drawer	CA/CH ID
19	VAT/tax 4	VAT 4	66	Change for cheque	CHK/CG
20	VAT/tax 5	VAT 5	67	Customer	GUEST
21	VAT/tax 6	VAT 6	68	Order total	ORDER TL
22	Net 1	NET1	69	Paid total	PAID TL
23	Net 2	NET2	70	Domestic currency 1	DOM.CUR1
24	Coupon-like PLU	CP PLU	71	Domestic currency 2	DOM.CUR2
25	Refund	REFUND	72	Domestic currency 3	DOM.CUR3
26	Void	∞	73	Domestic currency 4	DOM.CUR4
27	Void mode total	∞ MODE	74	Cheque in drawer	*CH ID
28	MGR void	MGR∞	75	Commission sale 1	COM.SAL1
29	Subtotal void	SBTL∞	76	Commission sale 2	COM.SAL2
30	Hash void	HASH∞	77	Commission sale 3	COM.SAL3
31	Hash refund	HASH RF	78	Commission sale 4	COM.SAL4
32	VAT shift	VAT SFT	79	Commission sale 5	COM.SAL5
33	VAT/tax delete	TAX DELE	80	Commission sale 6	COM.SAL6
34	VP counter	VP CNT	81	Commission sale 7	COM.SAL7
35	No sale	NO SALE	82	Commission sale 8	COM.SAL8
36	Guest check counter	G.C. CNT	83	Commission sale 9	COM.SAL9
37	RA	***RA	84	Non commission sale	NON.COM
38	RA2	***RA2	85	(+) Dept total	*DEPT TL
39	PO	***PO	86	(-) Dept total	DEPT (-)
40	PO2	***PO2	87	Hash (+) total	*HASH TL
41	Cheque cashing	CA/CHK	88	Hash (-) total	HASH (-)
42	Cash	CASH	89	Bottle return (+) total	*BTTL TL
43	Cash 2	CASH2	90	Bottle return (-) total	BTTL (-)
44	Cheque 1	CHECK	91	Net 1 (Taxable 1 - VAT/tax 1)	NET 1
45	Cheque 2	CHECK2	92	Net 2 (Taxable 2 - VAT/tax 2)	NET 2
46	Cheque 3	CHECK3	93	Net 3 (Taxable 3 - VAT/tax 3)	NET 3
47	Cheque 4	CHECK4	94	Net 4 (Taxable 4 - VAT/tax 4)	NET 4

Function no.	Key or function	Default setting	Function no.	Key or function	Default setting
95	Net 5 (Taxable 5 - VAT/tax 5)	NET 5	121	Net without tax	NET
96	Net 6 (Taxable 6 - VAT/tax 6)	NET 6	122	Commission amount 1	COM.AMT1
97	Subtotal	SUBTOTAL	123	Commission amount 2	COM.AMT2
98	Merchandise subtotal	MDSE ST	124	Commission amount 3	COM.AMT3
99	Difference subtotal	DIFF ST	125	Commission amount 4	COM.AMT4
100	Total	*** TOTAL	126	Commission amount 5	COM.AMT5
101	Change	CHANGE	127	Commission amount 6	COM.AMT6
102	Sales q'ty	ITEMS	128	Commission amount 7	COM.AMT7
103	Link PLU and EAN link subtotal	ITEM ST	129	Commission amount 8	COM.AMT8
104	Copy receipt title	COPY	130	Commission amount 9	COM.AMT9
105	Guest check copy title	G.C COPY	131	Commission amount total	COM.TTL
106	Average	AVE.	132	Department report title	DEPT
107	Group 1 for departments	GROUP01	133	Group report title	GROUP
108	Group 2 for departments	GROUP02	134	PLU report title	PLU
109	Group 3 for departments	GROUP03	135	Transaction report title	TRANS.
110	Group 4 for departments	GROUP04	136	Total in drawer report title	TL-ID
111	Group 5 for departments	GROUP05	137	Clerk report title	CLERK
112	Group 6 for departments	GROUP06	138	Cashier report title	CASHIER
113	Group 7 for departments	GROUP07	139	Hourly report title	HOURLY
114	Group 8 for departments	GROUP08	140	Daily net report title	DAILY
115	Group 9 for departments	GROUP09	141	PLU zero sales report title	ZERO SAL
116	CCD	CCD	142	PLU price category report title	CATEGORY
117	CCD differ	CCD DIF.	143	Commission sales report title	SALES
118	CCD differ total	DIF. TL	144	EAN report title	EAN
119	Order total-Paid total	O - P	145	EAN price change	PR.CHNG
120	Total tax	TTL TAX	146	Non accessed EAN report title	NO ACCES

10 Cashier and clerk programming

■ Cashier code PGM 1 PGM 2 1500

You can assign a cashier code to each cashier. (If the cashier's file is upgraded, a maximum of 99 cashiers can be programmed. Consult your dealer.)

Procedure

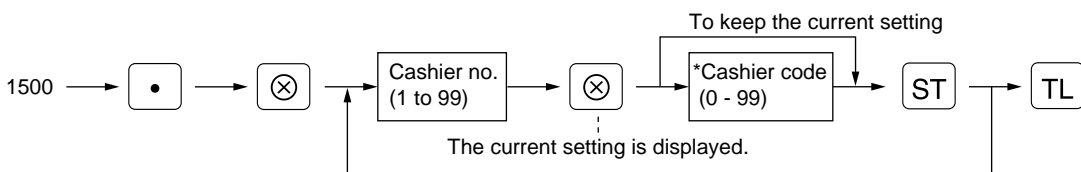

* Programming cashier code "0" inhibits entries of the cashier code.

Example

Key operation

1500
 1 11
 4 14

Print

```
#1500 *PGM2X
01CSR#          11
                0000D1
04CSR#          14
                0000D1
```

Cashier no.
Cashier code

■ Cashier name PGM 1 PGM 2 **1514**

You can program a maximum of 8 characters (cashier name) for each cashier. Select the characters you want to program referring to section "2 How to program alphanumeric characters" in chapter "PRIOR TO PROGRAMMING."

Procedure

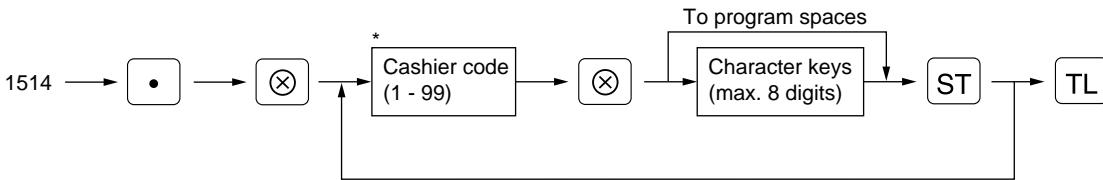

*: A cashier code you have programmed for the cashier by job code 1500

Example

Key operation

1514
 11 MAYER

Print

```
#1514 *PGM2X
01CSR#          11
MAYER          0000D1
```

■ Functional programming for cashiers PGM 2 **2510**

Procedure

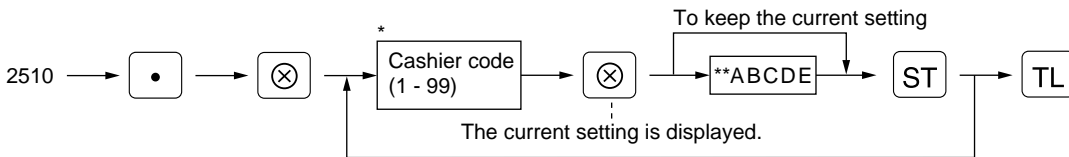

*: A cashier code you have programmed for the cashier by job code 1500

** Item:	Selection:	Entry:
A Guest check copy	Disable	1
	Enable	0
B VAT shift	Yes	1
	No	0
C and D Always enter 0.		0
E Drawer	Set the drawer no. 1 or 2	1 or 2
	Use no drawer	0

Example

Key operation

2510 • ⊗
 11 ⊗ 00001 ST
 TL

Print

```
#2510 *PGM2*
01CSR#           11
MAYER           000001
                E(Drawer no.)
                A through D
```

■ Clerk code PGM 1 PGM 2 **1400**

You can assign a clerk code to each of 99 clerks. The standard machine has no clerk function. If you need this function, consult your dealer.

Procedure

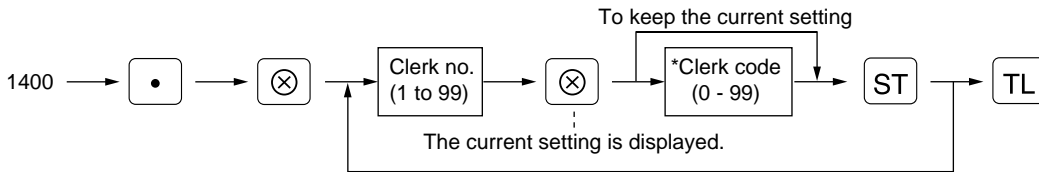

*: Programming clerk code "0" inhibits entries of the clerk code.

Example

Key operation

1400 • ⊗
 1 ⊗ 11 ST
 4 ⊗ 14 ST
 TL

Print

```
#1400 *PGM2*
01CLK#           11 Clerk no.
04CLK#           14 Clerk code
```

■ Clerk name PGM 1 PGM 2 **1414**

You can program a maximum of 8 characters (clerk name) for each clerk. Select the characters you want to program referring to section "2 How to program alphanumeric characters" in chapter "PRIOR TO PROGRAMMING."

Procedure

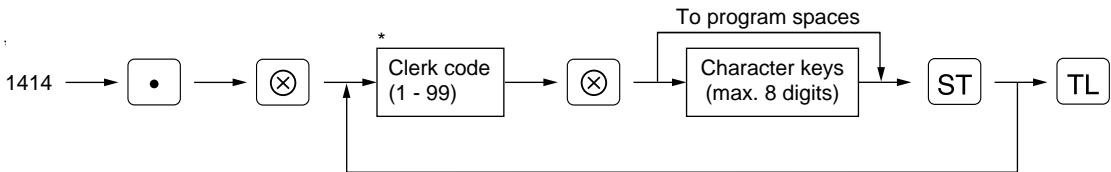

*: A clerk code you have programmed for the clerk by the job code 1400

Example

Key operation

1414 • ⊗
 11 ⊗ NILS ST
 TL

Print

```
#1414 *PGM2*
01CLK# NILS      11
```

11 Programming various functions

■ Programming for optional feature selection PGM 2 2616

OP X/Z mode availability

When a cashier needs to take the cashier/clerk X or Z report, he or she will use the OP X/Z mode. This programming determines whether he or she will be allowed to use this mode.

Note You can take cashier/clerk X and Z reports in the X1/Z1 mode regardless of the above programming.

Paid out in the REG-mode

Refund key in the REG-mode

Direct void in the REG-mode

Indirect void in the REG-mode

Subtotal void in the REG-mode

Refund validation printing

First item direct void

Printing of the number of purchased items

Journal print form

You may choose either of the following forms.

- Detailed journal print that shows the details of all entries - the same information as printed on the receipt.
- Summary journal print that shows information about all entries other than normal department entries (entries into "+" departments and their associated "+" PLUs).

Item validation print

Validation print for ⊖ entry

Zero skip for various reports

VAT/tax amount, taxable amount and net amount printing on the receipt/journal

VAT shift type

VAT shift by cashier: VAT shift is performed by the operation of a cashier who has been assigned to do the VAT shift operation (Refer to job# 2510).

VAT shift by shift key: VAT shift is performed by pressing the VAT shift key.

No sale in REG-mode

Finalization when the subtotal amount is zero in the REG mode

Exchange 1 calculation method (for EURO settings)

When you do not introduce EURO, keep the default setting (multiplication).

When you introduce EURO, this setting is automatically set by the operation of job #800.

The calculation method is as follows:

In case that "Division" is selected for the period 1,

Domestic currency amount (national currency amount) ÷ Exchange 1 rate (EURO conversion rate) = Exchange 1 amount (EURO amount)

In case that "Multiplication" is selected for the period 2,

Domestic currency amount (EURO amount) × Exchange 1 rate (EURO conversion rate) = Exchange 1 amount (national currency amount)

Printing of the exchange 1 total amount and change amount on the receipt/journal

Total and change amounts in exchange 1 currency are printed respectively below each of the total and exchange amounts in domestic currency.

When you introduce EURO, this setting is automatically set by the operation of job #800 as follows:

On the period 1, EURO amount converted from national currency is printed below the national currency, and on the the period 2, national currency converted from EURO amount is printed.

Validation printing of the exchange 1 total amount

Exchange 1 amount converted from total sales amount can be printed on the validation print for total amount when cash, cheque or credit amount tender is performed.

When you introduce EURO, this setting is automatically set by the operation of job #800.

Cash/credit operation for exchange 1

You can set whether you receive foreign currency (exchange 1) amount by cheque or credit or not.

Credit counting when received-on-account/paid out finalized with the credit key

Separator line in the report

Link PLU printing on the receipt

EAN learning function

Price change for EAN entry in REG-mode

Treatment of EAN 8 code (200XXXXC/D)

Treatment of EAN 13 code (2XXXXXXXXXXC/D)

Price entry after ISBN or ISSN

Entry of EAN with add-on code when the EAN ADD-ON file is full

Procedure

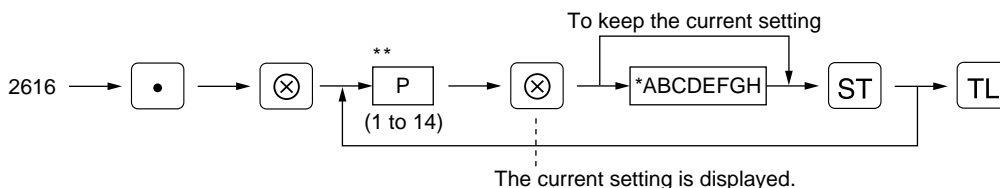

**P: 1

*

Item:	Selection:	Entry:
A	OP X/Z mode	Enable
		Disable
B	Paid-out in REG-mode	0
		1
C	Always enter 0.	0
		1
D	Refund key entry in the REG-mode	0
		1
E	Direct void in the REG-mode	0
		1
F	Indirect void in the REG-mode	0
		1
G	Subtotal void in the REG-mode	0
		1
H	Refund validation printing	Non-compulsory
		Compulsory

**P: 2

*

Item:	Selection:	Entry:
A The first item direct void	Enable	0
	Disable	1
B and C Always enter 0.		0
D Printing of the number of purchased items	No	0
	Yes	1
E Always enter 0.		0
F Journal print form	Detailed	0
	Limited	1
G Item validation printing	Enable	0
	Disable	1
H ☉ validation printing	Non-compulsory	0
	Compulsory	1

**P: 3

*

Item:	Selection:	Entry:
A Zero skip in EAN report	Yes	0
	No	1
B Zero skip in clerk report	Yes	0
	No	1
C Zero skip in cashier report	Yes	0
	No	1
D Zero skip in transaction report	Yes	0
	No	1
E Zero skip in department report	Yes	0
	No	1
F Zero skip in PLU report	Yes	0
	No	1
G Zero skip in hourly report	Yes	0
	No	1
H Zero skip in daily net report	Yes	0
	No	1

**P: 4

*

Item:	Selection:	Entry:
A and B Always enter 0.		0
C VAT/tax amount printing on the receipt/journal	Yes	0
	No	1
D Taxable amount printing on the receipt/journal	Yes	0
	No	1
E Net amount printing on the receipt/journal	Yes	0
	No	1
F to H Always enter 0.		0

**P: 5

*

Item:	Selection:	Entry:
A to C Always enter 0.		0
D VAT shift type	By cashier	0
	By shift key	1
E to H Always enter 0.		0

**P: 6 (ABCDEFGH: Always enter 0.)

**P: 7

*

Item:	Selection:	Entry:
A and B Always enter 0.		0
C No sale in REG-mode	Enable	0
	Disable	1
D Finalization in the REG-mode when the subtotal amount is zero	Enable	0
	Disable	1
E to H Always enter 0.		0

**P: 8 (ABCDEFGH: Always enter 0.)

**P: 9

*

Item:	Selection:	Entry:
A Always enter 0.		0
B Exchange 1 calculation method	Multiplication	0
	Division	1
C Cheque/credit operation for exchange 1	No	0
	Yes	1
D Printing exchange 1 total amount and change amount on receipt and journal	No	0
	Yes	1
E Printing exchange 1 total amount on validation printing	No	0
	Yes	1
F to H Always enter 0.		0

Note The items B, D and E are automatically set by the operation of job #800.

**P: 10

*

Item:	Selection:	Entry:
A and B Always enter 0.		0
C Learning function for EAN entry	Yes	0
	No	1
D to H Always enter 0.		0

**P: 11 (ABCDEFGH: Always enter 0.)

**P: 12

*

Item:	Selection:	Entry:
A to G Always enter 0.		0
H Price change for EAN entry in REG-mode	Enable	0
	Disable	1

■ Programming the limit on the number of times of validation printing and feed line after printing of a difference subtotal PGM 2 **2615**

Procedure

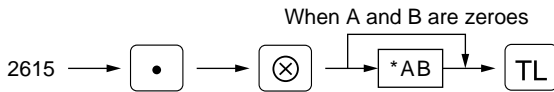

- * A: Validation printing counter (1 through 9 times)
To inhibit validation printing, enter 0.
- B: Feed lines after printing of difference subtotal (0 through 9)

Example

Key operation

2615 [•] [⊗]
10 [TL]

Print

```
#2615 *PGM2X
                                     10
```

■ Programming alarm length of time with drawer opening PGM 2 **2617**

If the drawer still remains open when a specified length of time has elapsed, your machine gives the alarm.

Procedure

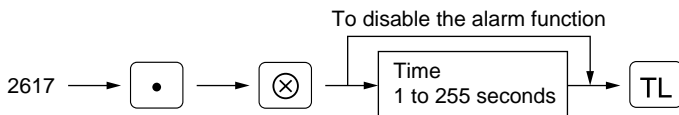

Example

Key operation

2617 [•] [⊗]
30 [TL]

Print

```
#2617 *PGM2X
                                     030
```

Note Your machine starts to monitor how long the drawer is kept open the moment the drawer is opened at the end of a transaction in the REG/VOID mode. It stops the time monitoring when a valid key (except the **VP** and **RCPT** keys) is pressed for the next transaction. It restarts the time monitoring after that transaction is ended. You can stop the buzzer alarm by closing the drawer. No key entries can be made while the buzzer is sounding.

■ Programming of print messages PGM 2 2614

Your register can print programmed messages for customers on every receipt.

Procedure

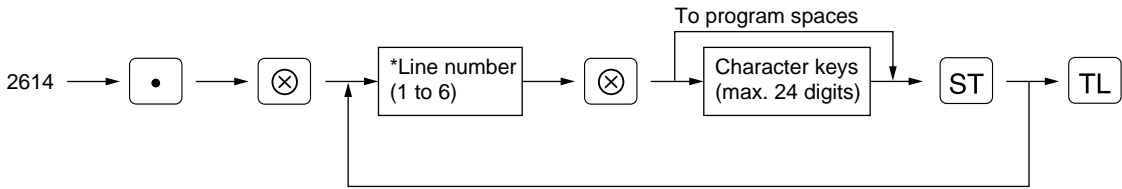

- * "Header 3-line message" type: 1 to 3
- "Footer 3-line message" type : 4 to 6
- "Header 6-line message" type: 1 to 6
- "Header 3-line and footer 3-line message" type: 1 to 6 (1 to 3 as header, 4 to 6 as footer)

A maximum of 6 lines are available. The type of printing "header 3-line message" is available for the standard model. The line numbers you select are according to the four types of printing: default setting, "header 3-line message" type, "footer 3-line message" type, "header 6-line message" type and "header 3-line and footer 3-line message" type. If you want to change the type of printing, please consult your dealer.

Select the characters you want to program, referring to section "2 how to program alphanumeric characters" in chapter "PRIOR TO PROGRAMMING."

Example

To program the following logo messages by using 3 lines:

```
=== YOUR ===
== STORE ==
MESSAGE
```

Key operation	Print
<p>2614 • ⊗</p> <p>1 ⊗ (SPACE) (SPACE) (SPACE) (SHIFT-2) = (SHIFT-2) = (SHIFT-2) = (SPACE)</p> <p style="margin-left: 20px;">(DC) Y (DC) O (DC) U (DC) R</p> <p style="margin-left: 20px;">(SPACE) (SHIFT-2) = (SHIFT-2) = (SHIFT-2) = ST</p> <p>2 ⊗ (SPACE) (SPACE) (SPACE) (SHIFT-2) = (SHIFT-2) = (SPACE)</p> <p style="margin-left: 20px;">(DC) S (DC) T (DC) O (DC) R (DC) E</p> <p style="margin-left: 20px;">(SPACE) (SHIFT-2) = (SHIFT-2) = ST</p> <p>3 ⊗ (SPACE) (SPACE) (SPACE) (SPACE)</p> <p style="margin-left: 20px;">(DC) M (DC) E (DC) S (DC) S (DC) A (DC) G (DC) E</p> <p style="margin-left: 20px;">ST</p> <p style="margin-left: 20px;">TL</p> <p>(SPACE):Space key)</p>	<div style="border: 1px solid black; padding: 10px; width: fit-content; margin: 0 auto;"> <p>#2614 XPGM2X</p> <p>=== YOUR ===</p> <p>== STORE ==</p> <p>MESSAGE</p> </div>

■ Selection of X1/Z1 and X2/Z2 reports to be printed in the stacked report sequence PGM 2 **2620**

Your register is equipped with the stacked report printing function that enables multiple X/Z reports to be printed in sequence with only a single request, up to maximum of 15 reports*. This function continuously prints a maximum of 15 kinds of reports with a single operation.

Procedure

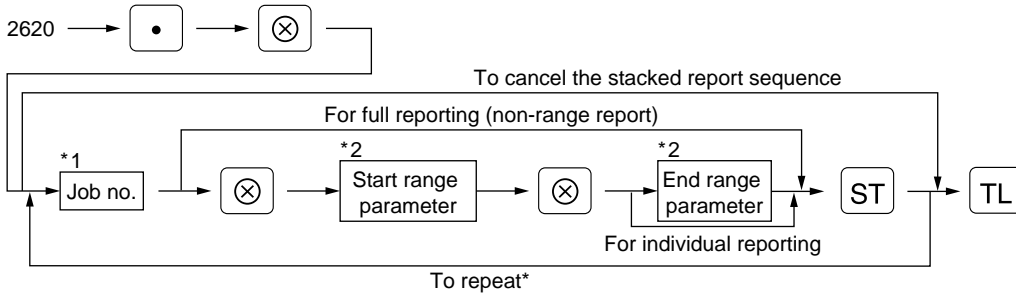

*: Maximum 70 steps are programmable. "1 step" means the memory size used for one no-range type job no. The range type job no. needs "8 steps".

Job code numbers to be used are as follows.

Job no.	Report	Available mode	Range parameter
00	General report		
07	EAN zero sales report	X1/X2 mode only	
09	Full EAN report		
10	Full department report	X1/X2 mode only	
13	Full department group report	X1/X2 mode only	
20	PLU report		*3 Start PLU code/end PLU code (1 through 999999)
27	PLU zero sales report	X1/X2 mode only	
29	PLU price category report	X1/X2 mode only	*3 Start price amount/end price amount
30	Transaction report	X1/X2 mode only	
31	Total in drawer report	X1/X2 mode only	
32	Commission sales report		
40	Full clerk report		
50	Full cashier report		
60	Hourly sales information	Range report is available only in the X1 mode.	*3 Start time/end time (0 through 2330)
70	Daily net report	X1/X2 mode only	

*3: Both range setting and full setting are allowed.

Note When Z of stacked report is initiated, X only reports will be skipped.

Example

Key operation

2620
 10
 13

Print

```
#2620 XPGM2X
                                     10
                                     13
```

■ Setting the time range for hourly reports PGM 2 **2619**

You can set the time range for an hourly report.

Procedure

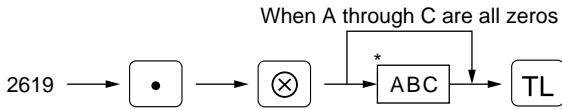

*A: Time range

To set the time range to 30 minutes (in the 24-hour system), enter 0.

To set the time range to 60 minutes (in the 24-hour system), enter 1.

BC: Starting time (hour = 00 to 23)

Example

Key operation

2619
107

Print

```
#2619 *PGM2*
                1 07
```

Note To perform this setting, an hourly Z report (# 160) must be done.

■ RS-232C channel assignment PGM 2 **2690**

Your machine is equipped with two RS-232C interfaces. If you use the on-line communication function and/or the barcode reader, the channel number of each RS-232C interface must be programmed by using the following procedure.

To realize the on-line communication and/or to use the barcode reader, consult your dealer.

Procedure

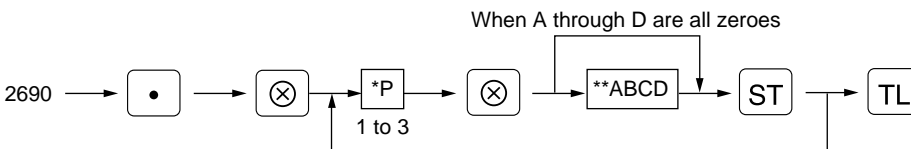

*P: 1

** Item:	Selection:	Entry:
A Channel no. for the ON-LINE communication	Not connected	0
	Standard port 2	1
	Standard port 1	8
B to D Always enter 0.		0

*P: 2

** Item:	Selection:	Entry:
A Channel no. for the barcode reader	Not connected	0
	Standard port 2	1
	Standard port 1	8
B to D Always enter 0.		0

*P: 3 (ABCD: Not used. Always enter 0.)

Note Never enter any number other than 0, 1 and 8.

Example

Key operation

2690 [•] [⊗]
 1 [⊗] [ST]
 [TL]

Print

```
#2690 XPGM2X
1 _____ P
                0000 A through D
```

Barcode reader programming PGM 2 2691

Procedure

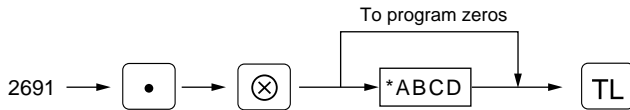

* Item:	Selection:	Entry:
A	Data bit	7 bits
		8 bits
B	Parity bit	Non parity
		Odd parity
		Even parity
C	Stop bit	1 bit
		2 bits
D	Transmission speed	19200 bps
		9600 bps
		4800 bps

Example

Key operation

2691 [•] [⊗]
 1110 [TL]

Print

```
#2691 XPGM2X
                1110 ABCD
```

■ Setting the AUTO key — Automatic sequencing key — X2/Z2 2900

If you program frequently performed transactions or report sequences for the AUTO keys, you can call those transactions and/or reports simply by pressing the corresponding AUTO keys in key operations. This programming can be done when your machine is in the X2/Z2 mode.

Procedure

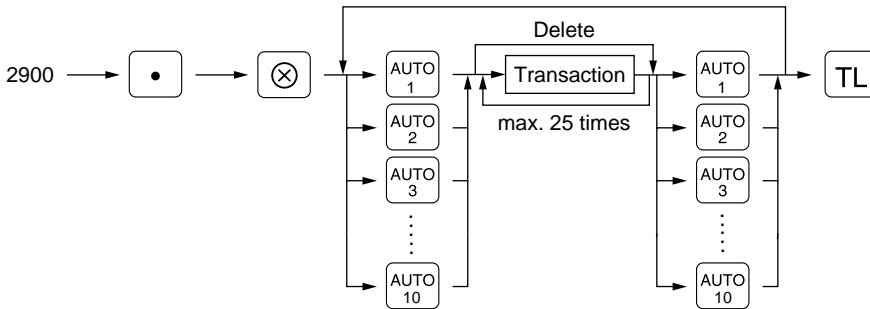

Example

Programming for **AUTO 1** key and **AUTO 2** key as follows:

- AUTO 1**; entering a PLU 2 item (programmed unit price: 1.50) and a dept. 6 item (unit price: 1.00)
- AUTO 2**; selling a dept. 7 item (programmed unit price: 5.00) for cash

Key operation	Print
2900 . ⊗	#2900 XPGM2X
AUTO1 → 2 PLU/SUB 100 6	#01
AUTO2 setting → 7 TL	2 KEY PLU 1 KEY 0 KEY 0 KEY D06
	#02
	D07 TOTAL

Note When the AUTO key has been programmed to execute a report job function etc., the mode switch must be in the appropriate position (X1/Z1 or X2/Z2).

12 Reading stored programs

Your machine allows you to read every program stored in the PGM1 and PGM2 modes.

Program details and procedures for their reading

Program for:		Mode switch position	Job code no.	Procedure	Related PGM1/ PGM2 job code nos.
1	Departments	PGM2 or PGM1	1100		1110, 2110, 2111, 2112, 2114, 2115, 2116
2	PLUs/ subdepartments	PGM2 or PGM1	1200		1200, 1210, 1211, 2210, 2211, 2214, 2215, 2230, 2231, 2232, 2235
3	Key nos. for departments and PLUs	PGM2	2119		2119, 2219
4	Link PLUs	PGM2	2220		2220
5	EANs	PGM1 or PGM2	1000		1000, 1010, 1011, 2010, 2011, 2014, 2015
6	EANs function	PGM2	2025		2025, 2029, 2035
7	EAN link	PGM2	2030		2030
8	Cashiers	PGM2 or PGM1	1500		1500, 1514, 2510
9	Clerks	PGM2 or PGM1	1400		1400, 1414
10	Function preset 1	PGM2 or PGM1	1300		1310, 2311, 2312, 2313, 2314, 2315, 2316, 2320, 2321, 2322, 2330, 2334
11	Function preset 2	PGM2	2600		2614, 2615, 2616, 2617, 2619, 2620, 2630, 2631, 2632, 2680, 2690, 2691

Program for:		Mode switch position	Job code no.	Procedure	Related PGM1/ PGM2 job code nos.
12	Tax rates	PGM2	2700	→ 2700 → ⊗ → TL	2711
13	Auto keys	PGM2	2900	→ 2900 → ⊗ → TL	2900

■ Sample printouts

1 Reading of programmed items for departments (Reading in the PGM1 and PGM2 modes)

2 Reading of programmed items for PLUs/subdepartments (Reading in the PGM1 and PGM2 modes)

<p>31/08/01 16:07 11 123456 #1437 MAVER 11 NILS</p> <p>Job code no. #1100 *PGM2*</p> <p>Range 01-20</p> <p>Dept. code D01 T1 10.00</p> <p>Item label FRUITS 001</p> <p>0000003 0 C1L18</p> <p>D02 T1 3 15.25</p> <p>DPT.02 001</p> <p>0000003 0 C2L18</p> <p>D03 0.00</p> <p>DPT.03 003</p> <p>0000001 0 C3L18</p> <p>D04 0.00</p> <p>DPT.04 001</p> <p>0000001 0 C1L18</p> <hr/> <p>D19 0.00</p> <p>DPT.19 001</p> <p>0000001 0 COL18</p> <p>D20 -0.50</p> <p>DPT.20 014</p> <p>0000003 0 COL18</p>	<p>Mode switch position*</p> <p>Tax status</p> <p>Unit price</p> <p>Group no.</p> <p>HALO limit</p> <p>Commission group</p> <p>Function programming</p> <p>Type of unit price entry</p> <p>Type (SIF/SICS/Normal)</p> <p>Item validation print compulsory/non-compulsory</p> <p>Minus department</p>	<p>31/08/01 16:23 11 123456 #1570 MAVER 12 BETH</p> <p>#1200 *PGM2*</p> <p>Range 000001-999999</p> <p>PLU code P000001(O2) /00</p> <p>T1 1.25</p> <p>Item label MILK 003 C1</p> <p>003</p> <p>P000002(O2) /12</p> <p>T1 1.50</p> <p>PL000002 00</p> <p>002 0 0 2</p> <p>P000003(O3) /00</p> <p>003 0.00</p> <p>PL000003 001</p> <p>002</p> <p>P000004(O1) /00</p> <p>002 0.00</p> <p>PL000004 00</p> <p>002</p> <hr/> <p>P000020(O3) /00</p> <p>T1 0.00</p> <p>PL000020 00</p> <p>003</p> <p>P000021(O1) L /00</p> <p>3.50</p> <p>PL000021 00</p> <p>002</p> <p>P000025(O1) /00</p> <p>3.00</p> <p>PL000025 00</p> <p>002</p>	<p>Mode switch position*</p> <p>Range</p> <p>Associated dept. code</p> <p>Unit price</p> <p>Tax status</p> <p>Base q'ty</p> <p>Mode parameter</p> <p>Commission group</p> <p>Link PLU</p>
--	--	---	---

* When you take this report in the PGM1 mode, the PGM2 indication is replaced by a "PGM1".

**3 Reading of programmed key nos. for departments and PLUs
(Reading in the PGM2 mode)**

```

31/08/01 7:36      11
123456 #1443      MAVER
11 NILS

#2119 *PGM2X

Key no.
Dept. code
001      D01
002      D02
003      D03
004      D04
005      D05
006      D06
007      D07
008      D08
009      D09
010      D10
011      D11
012      D12
013      D13
014      D14
015      D15
016      P000001 PLU code
017      D17
018      D18
019      D19
020      D20
021      ----
022      ----
023      ----
024      ----
025      ----
026      ----
027      ----
028      ----
029      ----
030      ----
031      ----
032      ----
033      ----
034      ----
035      ----
036      ----

066      ----
067      ----
068      ----
    
```

**4 Reading of programmed items for link PLUs
(Reading in the PGM2 mode)**

```

31/08/01 16:39
123456 #1571

#2220 *PGM2X

000001-999999 Range
Leading PLU code P000021 LP000025 Linked PLU code
P000026
P000027
    
```

**5 Reading of programmed items for EANs (1)
(Reading in the PGM1 and PGM2 modes)**

```

31/08/01 18:15      11
123456 #1505      MAVER
11 NILS

#1000 *PGM2X Mode switch position*
EAN code 5012345678900#L (02)/05 Type L: Linked with PLUs (space): Normal
Delete method XT1 2.50 Unit price
Item label APPLE C1 Commission group
5056789123404# (05)/05 Base q'ty
Tax status T 2 3.00 Associated dept. code
ORANGE C1
    
```

* When you take this report in the PGM1 mode, the PGM2 indication is replaced by a "PGM1".

Note The EAN codes are printed out in the sequence shown below.

EAN-13
EAN-8
In-store marking PLU short type
In-store marking Non-PLU short type
UPC-A
UPC-E

6 Reading of programmed items for EANs (2)
(Reading in the PGM2 mode)

31/08/01 18:15	11	
123456 #1506	MAVER	
11 NILS		
#2025 *PGM2*		
#2025		
20	5 4 0 0 1 2	Non-PLU format setting
02	4 5 0 0 1 2	
2	2 4 1 0 0 2	
#2029	60	Delete period
#2035		
1	111	Press code function
2	001	
3	001	
4	001	
5	001	

8 Reading of programmed items for cashiers
(Reading in the PGM1 and PGM2 modes)

31/08/01 7:37	11		
123456 #1444	MAVER		
11 NILS			
#1500 *PGM2*			
Cashier no.	D1CSR#	11	Cashier code
Cashier name	MAVER	000001	Drawer no.
	02CSR#	02	VAT shift yes/no
	03CSR#	000001	Guest check copy yes/no
		03	
	04CSR#	000001	
		00	
		000001	

* When you take this report in the PGM1 mode, the PGM2 indication is replaced by a "PGM1".

7 Reading of programmed items for EAN link
(Reading in the PGM2 mode)

31/08/01 18:16	11	
123456 #1507	MAVER	
11 NILS		
#2030 *PGM2*		
	5012345678900#L	EAN code
	P000030	Linked PLU codes
	P000031	
	P000032	

9 Reading of programmed items for clerks
(Reading in the PGM1 and PGM2 mode)

31/08/01 7:49	11			
123456 #1451	MAVER			
11 NILS				
#1400 *PGM2*				
Clerk no.	D1CLK#	NILS	11	Clerk code
Clerk name	02CLK#	BETH	12	
	03CLK#		03	
	04CLK#		14	

* When you take this report in the PGM1 mode, the PGM2 indication is replaced by a "PGM1".

10 Reading of programmed items for functions - 1
(Reading in the PGM1 and PGM2 modes)

```

31/08/01 18:18      11
123456 #1509      MAYER
11 NILS

#1300 *PGM2*
-----
F001 (-)1
I          -10.00
           L13

F002 (-)2
S          -0.00
           L18

F005 %1
S          -5.00%
           L100.00%

F006 %2
I          -10.00%
           L100.00%

F010 TAX1 ST
F011 TAX2 ST
F012 TAX3 ST
F013 TAX4 ST
F014 TAX5 ST
F015 TAX6 ST
F016 VAT 1
F017 VAT 2
F018 VAT 3
F019 VAT 4
F020 VAT 5
F021 VAT 6
F022 NET1
F023 NET2
F024 CP PLU
F025 REFUND
F026 *
F027 * MODE
F028 MGR *
F029 SBTL *
F030 HASH *
F031 HASH RF
F032 VAT SFT
F033 TAX DELE
F034 VP CNT

```

Mode switch position*

```

F035 NO SALE
F036 G.C. CNT
F037 XXXRA          L18
F038 XXXRA2        L18
F039 XXXPD         L18
F040 XXXPD2        L18
F041 CA/CHK
           999999.99
F042 CASH          L18
           0000000
F043 CASH2         L18
           0000000
F044 CHECK         L18
           0000000
F045 CHECK2        L18
           0000000
F046 CHECK3        L18
           0000000
F047 CHECK4        L18
           0000000
F048 CREDIT1       L18
           0000000
F049 CREDIT2       L18
           0000000
F050 CREDIT3       L18
           0000000
F051 CREDIT4       L18
           0000000
F052 EXCH1         DM
           0          1.955830
F053 EXCH2         2          1.019000
F054 EXCH3         2          0.000000
F055 EXCH4         2
F056 EXCH1 IS
F057 EXCH2 IS
F058 EXCH3 IS
F059 EX1 CHK
F060 DOM.CUR1
F061 EX1 CR
F062 DOM.CUR1
F063 XXXCID
           9999999.99
F064 CA/CH IS
F065 CA/CH IO

```

* When you take this report in the PGM1 mode, the PGM2 indication is replaced by a "PGM1".

To be continued on the next page

F066 CHK/CG
 999999.99
F067 GUEST
F068 ORDER TL
F069 PAID TL
F070 DOM.CUR1
F071 DOM.CUR2
F072 DOM.CUR3
F073 DOM.CUR4
F074 *CH ID
F075 COM.SAL1
 0.00%
F076 COM.SAL2
 0.00%
F077 COM.SAL3
 0.00%
F078 COM.SAL4
 0.00%
F079 COM.SAL5
 0.00%
F080 COM.SAL6
 0.00%
F081 COM.SAL7
 0.00%
F082 COM.SAL8
 0.00%
F083 COM.SAL9
 0.00%
F084 NON COM.
F085 *DEPT TL
F086 DEPT(-)
F087 *HASH TL
F088 HASH(-)
F089 *BTTL TL
F090 BTTL(-)
F091 NET 1
F092 NET 2
F093 NET 3
F094 NET 4
F095 NET 5
F096 NET 6
F097 SUBTOTAL
F098 MDSE ST
F100 ***TOTAL
F101 CHANGE
F102 ITEMS
F103 ITEM ST
F104 COPY

F105 G.C COPY
F106 AVE.
F107 GROUP01
F108 GROUP02
F109 GROUP03
F110 GROUP04
F111 GROUP05
F112 GROUP06
F113 GROUP07
F114 GROUP08
F115 GROUP09
F116 CCD
F117 CCD DIF.
F118 DIF. TL
F119 O-P
F120 TTL TAX
F121 NET
F122 COM.AMT1
F123 COM.AMT2
F124 COM.AMT3
F125 COM.AMT4
F126 COM.AMT5
F127 COM.AMT6
F128 COM.AMT7
F129 COM.AMT8
F130 COM.AMT9
F131 COM.TTL
F132 DEPT
F133 GROUP
F134 PLU
F135 TRANS.
F136 TL-ID
F137 CLERK
F138 CASHIER
F139 HOURLY
F140 DAILY
F141 ZERO SAL
F142 CATEGORY
F143 SALES
F144 EAN
F145 PR.CHNG
F146 NO ACCE

**11 Reading of programmed items for functions - 2
(Reading in the PGM2 mode)**

```

31/08/01 18:17      11
123456 #1508  MAYER
11 NILS

#2600 *PGM2*

#2614 ----- Print message
== YOUR ==
== STORE ==
MESSAGE

#2615          10
#2616          10 Validation printing counter
01          00000000
02          00000000
03          00000000
04          00000000
05          00010000
06          00000000
07          00000000
08          00000000
09          00100000
10          00000000
11          00000000
12          00000000
13          00000100
14          00000000
#2617          000 Drawer open alarm time
#2619          0 00 Hourly report format/start hour
#2620          10 Stacked report
           13
#2630          0000 Secret code
#2631          0000
#2632          0000
#2680          0 Drawer no. for the drawer for foreign currency
#2690          1
           0000 RS-232C channel data
           2
           0000
           3
           0000
#2691          1110 Barcode reader programming
    
```

**12 Reading of programmed tax rates
(Reading in the PGM2 mode)**

```

31/08/01 8:05      11
123456 #1464  MAYER
11 NILS

#2700 *PGM2*

TAX1          5.0000% Tax rate
                0.12 Lowest taxable amount
TAX2          4.0000%
                0.12
TAX3          6.0000%
                0.20
TAX4          -----
TAX5          -----
TAX6          -----
    
```

**13 Reading of programmed items for auto keys
(Reading in the PGM2 mode)**

```

31/08/01 7:57      11
123456 #1457  MAYER
11 NILS

#2900 *PGM2*

#01
           2 KEY
           PLU
           1 KEY
           0 KEY
           0 KEY
           D06
#02
           D07
           TOTAL
#03
           -----
#04
           -----

#10
           -----
    
```

13 Training mode

The training mode is used when the operator or the manager practices register operations.

When a cashier set in training is selected, the machine automatically enters the training mode. When a cashier not set in training is selected, the machine automatically enters the ordinary REG mode. (For programming, consult your dealer.)

The training operations is valid only in REG, MGR and VOID mode.

The corresponding cashier memory is updated in the training mode. Other memories are not updated.

Key operation	Print
1000 <input type="button" value="5"/>	<div style="border: 1px solid black; padding: 5px;"><pre>31/08/01 14:47 03 123456 #1550 TOM 12 BETH TRAINING DPT.05 ¥10.00 3x 24.00 DPT.03 ¥72.00 CASH ¥82.00</pre></div>
3 <input type="button" value="⊗"/>	
<input type="button" value="3"/>	
<input type="button" value="TL"/>	

READING (X) AND RESETTING (Z) OF SALES TOTALS

- Use the reading function (X) when you need to take a reading of sales information entered since the last resetting. You can take this reading any number of times. It does not affect the register's memory.
- Use the resetting function (Z) when you need to clear the register's memory. Resetting prints all sales information and clears the entire memory except for the GT1 through GT3 and training GT, reset count, and consecutive number.

1 Summary of reading (X) and resetting (Z) reports and the key operations to obtain the reports

X1 and Z1 reports: Daily sales reports

X2 and Z2 reports: Periodic (monthly) consolidation reports

Item	Mode switch position		Job code	Key operation
	X1/Z1	X2/Z2		
Flash report: (Only display) To clear the display, press the CL key or turn the mode switch to another position.	X1	—	—	Dept. key (1 to 50) Dept. code → DEPT # : Department total amount
				⊗ key: Amount of cash in drawer
				ST key: Sales total
Full reading and resetting	X1, Z1	X1, Z1	100	100 → Reading → ⊗ → TL 200 → Resetting
		X2, Z2	200	
Individual clerk reading and resetting	X1, Z1	X1, Z1	141	141 → Reading → ⊗ → TL 241 → Resetting
		X2, Z2	241	
	<OP X/Z> X, Z		41	41 → Reading → ⊗ → TL → Resetting
Individual cashier reading and resetting	X1, Z1	X1, Z1	151	151 → Reading → ⊗ → TL 251 → Resetting
		X2, Z2	251	
	<OP X/Z> X, Z		51	51 → Reading → ⊗ → TL → Resetting
Full clerk reading and resetting	X1, Z1	X1, Z1	140	140 → Reading → ⊗ → TL 240 → Resetting
		X2, Z2	240	
Full cashier reading and resetting	X1, Z1	X1, Z1	150	150 → Reading → ⊗ → TL 250 → Resetting
		X2, Z2	250	
Full department reading	X1	X1	110	110 → ⊗ → TL
		X2	210	
Individual group reading	X1	X1	112	112 → ⊗ → Group no. → TL
		X2	212	
Full group reading	X1	X1	113	113 → ⊗ → TL
		X2	213	

Item	Mode switch position		Job code	Key operation
	X1/Z1	X2/Z2		
Commission sales report	X1	X1	132	132 → ⊗ → TL 232 → ⊗ → TL
		X2	232	
Reading and resetting of sales information for a range of PLUs/ subdepartments	X1, Z1	X1, Z1	120	
		X2, Z2	220	
Reading of sales information of PLUs/ subdepartments associated with an individual department	X1	X1	121	121 → ⊗ → Dept. code → TL 221 → ⊗ → Dept. code → TL
		X2	221	
Reading of sales information on PLUs/ subdepartments whose sales amounts are zeros	X1	X1	127	127 → ⊗ → TL 227 → ⊗ → TL
		X2	227	
Reading of PLU/ subdepartments whose sales amounts are zeros (by associated department)	X1	X1	127	127 → ⊗ → Dept. code → TL 227 → ⊗ → Dept. code → TL
		X2	227	
Reading of sales information for the price amount range of PLUs/sub department	X1	X1	129	
		X2	229	
Reading and resetting of sales information for EANs	X1, Z1	X1, Z1	109	
		X2, Z2	209	
Reading and resetting of sales information for EANs associated with an individual department	X1, Z1	X1, Z1	101	
		X2, Z2	201	
Reading of EANs whose sales amounts are zeros	X1	X1	107	107 → ⊗ → TL 207 → ⊗ → TL
		X2	207	

Item	Mode switch position		Job code	Key operation
	X1/Z1	X2/Z2		
Reading of EANs whose sales amounts are zeros (by associated department)	X1	X1	107	107 → ⊗ → Dept. code → TL
		X2	207	
Transaction reading	X1	X1	130	130 → ⊗ → TL
		X2	230	
Total in drawer	X1	X1	131	131 → ⊗ → TL
		X2	231	
Reading and resetting of hourly sales information	X1		160	Reading: 160 → ⊗ → Start* time → ⊗ → End* time → TL * Enter the time in the 24-hour system.
	X1, Z1			
Reading and resetting of a stacked report	X1, Z1	X1, Z1	190	190 → ⊙ → Reading → ⊗ → TL Resetting
		X2, Z2	290	
Reading and resetting of the daily net totals		X2, Z2	270	270 → ⊙ → Reading → ⊗ → TL Resetting

Note Individual and full clerk reading and resetting are available only in the cashier and clerk system. In the factory setting, the register provides the "cashier only" system. So, if you want to change the system, consult your dealer.

Non-accessed EAN deleting

Item	Mode switch position		Job code	Key operation
	X1/Z1	X2/Z2		
Reading of non-accessed EANs	X1		105	105 → ⊗ → TL
Deleting of non-accessed EANs	Z1		105	105 → ⊙ → ⊗ → TL For full deleting For the last picking list → ⊗ → TL Scan EAN code → ⊗ → TL EAN code → ⊗ → TL To pick up EAN codes

Note When you execute the job #105 in Z1 mode, not only the sales data, but also the EAN code(s) (the related data files) themselves will be deleted.

2 Daily sales totals

■ Full reading and resetting of sales totals

You can take X and Z reports in the X1/Z1 mode. The use of the decimal key (\square) determines when the report will actually reset the sales totals.

• Sample X report

31/08/01 22:42	11	
123456 #1668	MAYER	
11 NILS		
#100 *X1*		Report no.
TR	*00000000318.65	Read symbol
%DEPT%		
D01	161.563 Q	Dept. code
DPT.01	*1031.33	Sales q'ty
	56.04%	Sales amount
D04	2.000 Q	Ratio of dept.1 sales amount to "+" dept. total
DPT.04	*11.00	
	0.60%	
D05	68.250 Q	
DPT.05	*341.75	
	18.57%	
D09	7.000 Q	
DPT.09	*100.28	
	5.45%	
GROUP01	290.813 Q	Group1 sales q'ty
	*1840.22	Group1 sales amount
	82.31%	Ratio of dept. group1 sales amount to "+" department
D02	59.000 Q	
DPT.02	*335.55	
	100.00%	
GROUP02	59.000 Q	
	*335.55	
	15.01%	
XDEPT TL	354.813 Q	} "+" dept. counter and total
	*2235.77	
	100.00%	
D10	5.000 Q	} "-" dept. counter and total
DPT.10	-10.00	
DEPT(-)	5.000 Q	
	-10.00	

To be continued on the next page

• Sample Z report

31/08/01 1:23	11	
123456 #1689	MAYER	
11 NILS		
#100 *Z1*		Report no.
	Z1 0001	Reset symbol
		Reset counter
GT1	*00000027192.47	Net grand total (GT2 - GT3)
GT2	*00000027981.50	Grand total of plus registration
GT3	-00000000789.03	Grand total of minus registration
TR	*00000000318.65	Grand total of training mode registration

The subsequent printout occurs in the same format as in the X report.

Note

Not all reports provide the resetting capability. Please refer to the chart on pages 94 through 96.

D11	6.000 0	
DPT.11	¥19.50	
¥HASH TL	6.000 0	} "+" hash dept. counter and total
	¥19.50	
D12	7.000 0	
DPT.12	-8.75	
HASH(-)	7.000 0	} "-" hash dept. counter and total
	-8.75	
D13	8.000 0	
DPT.13	¥20.00	
¥BTTL TL	8.000 0	} "+" bottle return dept. counter and total
	¥20.00	
D14	5.000 0	
DPT.14	-2.50	
BTTL(-)	5.000 0	} "-" bottle return dept. counter and total
	-2.50	
¥ TRANS. ¥		
(-)1	1 0	} Subtotal ⊖1 counter and total
	-0.50	
(-)2	2 0	
	-1.65	
¥1	3 0	} Subtotal percent 1 counter and total
	-1.79	
NET1	¥2239.33	— Net sales total
TAX1 ST	¥623.04	— Taxable 1 total
VAT 1	¥29.67	— VAT 1 total
TAX2 ST	¥115.48	
VAT 2	¥4.44	

VAT 6	¥7.77	
TTL TAX	¥47.23	— Tax total
NET	¥2192.10	— Net total without tax
VAT SFT	¥30.00	— VAT shift total
TAX DELE	¥4.50	— Tax delete total
(-)3	1 0	} Item ⊖3 counter and total
	-0.35	
(-)4	1 0	
	-0.05	
¥2	1 0	} Item percent 2 counter and total
	-1.00	
¥3	1 0	
	-1.00	
¥4	2 0	
	-6.20	

To be continued on the next page

REFUND	14 Q		} Refund counter and total
		X81.20	
↵	16 Q		} REG-mode void counter and total
		X78.58	
↵ MODE	2 Q		} Void-mode transaction counter and total
		X388.15	
MGR #	3 Q		} Manager item void counter and total
		X388.15	
SETL #	3 Q		} Subtotal void counter and total
		X203.00	
HASH #	1 Q		} Hash item void counter and total
		X10.00	
HASH RF	1 Q		} Hash item refund counter and total
		X10.00	
VP CNT	2 Q		— Validation print counter
NO SALE	1 Q		— No-sale (exchange) counter
G.C. CNT	1 Q		— Gest check copy counter
GUEST	118 Q		— Customer counter
ORDER TL		X2250.08	— Order total
PAID TL		X2201.58	— Paid total
AVE.		X18.66	— Paid total average per customer
O-F		X48.50	— Order total - paid total
XXXRA	2 Q		} Received on account counter and total
		X35.00	
XXXRA2	1 Q		} Paid out counter and total
		X20.00	
XXXPD	1 Q		
		X10.00	
XXXPD2	1 Q		} Cheque cashing counter and total
		X15.00	
CA/CHK	2 Q		} Cheque cashing counter and total
		X50.00	
CASH	91 Q		} Cash counter and total
		X1548.17	
CASH2	3 Q		} Cheque 1 sales counter and total
		X21.25	
CHECK	3 Q		
		X35.00	
CHECK2	1 Q		} Credit 1 sale and tendering counter and total
		X13.00	
CHECK3	1 Q		
		X13.56	
CHECK4	2 Q		} Credit 1 sale and tendering counter and total
		X30.00	
CREDIT1	2 Q		
		X50.00	} Credit 1 sale and tendering counter and total
CREDIT2	1 Q		
		X36.25	

To be continued on the next page

CREDIT3	1 0	
	¥28.00	
CREDIT4	1 0	
	¥36.00	
EXCH1	5 0	} Exchange 1 counter and total
	DM397.00	
DDM.CUR1	¥220.28	
EX1 CHK	1 0	} Exchange 1 cheque 1-4 counter and total
	DM50.00	
DDM.CUR1	¥25.56	— Exchange 1 cheque 1-4 total in domestic currency
EX1 CR	2 0	} Exchange 1 credit 1-4 counter and total
	DM95.06	
DDM.CUR1	¥48.60	— Exchange 1 credit 1-4 total in domestic currency
EXCH2	1 0	
	23.47	
DDM.CUR2	¥12.00	
EXCH3	1 0	
	45.08	
DDM.CUR3	¥23.00	
EXCH4	2 0	
	140.00	
DDM.CUR4	¥123.93	
***CID	¥1451.40	— Cash in drawer
XCH ID	¥166.56	— Cheque in drawer
CA/CH ID	¥1617.96	— Cash + cheque in drawer
CHK/CG	¥11.46	— Change total for cheque tendering

■ Cashier reading and resetting

Using this function, you can take X and Z reports for individual cashiers or all cashiers.

Individual cashier reading and resetting

Note

The OP X/Z-mode reading and resetting is allowed only when your machine has been programmed for "OP X/Z mode available" in the PGM2 mode.

• Sample X report

```

31/08/01 21:15      11
123456 #1677  MAVER
11 NILS

#151 *X1*
XCASHIER *
D1CSR#11 MAVER
ORDER TL      *1886.63
PAID TL       *1838.13
AVE.          *20.20
REFUND        14 Q
              *81.20
              16 Q
              *78.58
              1 Q
MGR  *        *69.50
              2 Q
              *69.50
SETL  *       2 Q
              *191.00
G.C. CNT      1 Q
GUEST        91 Q

***RA        2 Q
              *35.00
***RA2       1 Q
              *20.00
***PD        1 Q
              *10.00
***PD2       1 Q
              *15.00
CA/CHK       2 Q
              *50.00

CASH         64 Q
              *1184.72
CASH2        3 Q
              *21.25
CHECK        3 Q
              *35.00
CHECK2       1 Q
              *13.00
    
```

Cashier no./cashier code
 Cashier name
 Order total
 Paid total
 Average

• Sample Z report

```

31/08/01 21:18      11
123456 #1678  MAVER
11 NILS

#151 *Z1*
XCASHIER *
D1CSR#11 MAVER
    
```

The subsequent printout occurs in the same format as in the sample X report.

To be continued on the next page

* When you take these reports in the OP X/Z mode, the X report shows an "OP X" and the Z report shows an "OP Z".

CHECK3	1 Q	
		*13.56
CHECK4	2 Q	
		*30.00
CREDIT1	2 Q	
		*50.00
CREDIT2	1 Q	
		*36.25
CREDIT3	1 Q	
		*28.00
CREDIT4	1 Q	
		*36.00
EXCH1	5 Q	
		DM397.00
DDM.CUR1		*220.28
EX1 CHK	1 Q	
		DM50.00
DDM.CUR1		*25.56
EX1 CR	2 Q	
		DM95.06
DDM.CUR1		*48.60
EXCH2	1 Q	
		23.47
DDM.CUR2		*12.00
EXCH3	1 Q	
		45.08
DDM.CUR3		*23.00
EXCH4	2 Q	
		140.00
DDM.CUR4		*123.93
***CID		*1087.95
*CH ID		*166.56
CA/CH ID		*1254.51
CHK/CG		*11.46

Full cashier reading and resetting

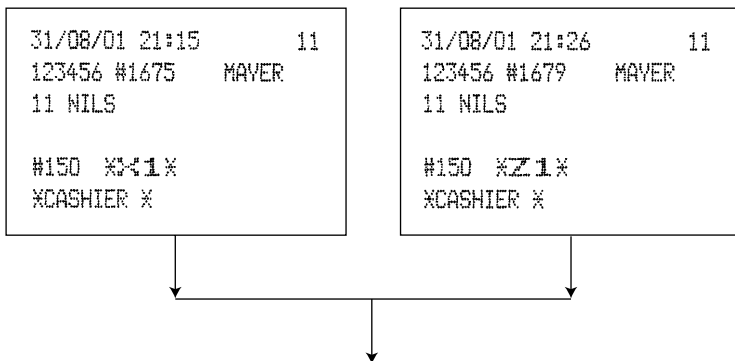

The subsequent printout occurs in the same format as in the sample reports of individual cashier reading and resetting, and sales data for cashiers print in this sequence.

■ Clerk reading and resetting

Using this function, you can take X and Z reports for individual clerks or all clerks.

Individual clerk reading and resetting

Note

The OP X/Z-mode reading and resetting is allowed only when your machine has been programmed for "OP X/Z mode available" in the PGM2 mode.

• Sample X report

```

31/08/01 22:41      11
123456 #1667      MAVER
11 NILS

#141 X<1X
X CLERK X
-----
01CLK#1 1      NILS      Clerk no./clerk code
ORDER TL      X22362.23    Clerk name
COM.SAL1      X252.75     Order total
COM.SAL2      X11116.71   Commission sales
COM.SAL4      X74.23      1 total amount
COM.SAL5      X58.41
COM.SAL6      X24.85
COM.SAL7      X31.00
COM.SAL8      X44.54
COM.SAL9      X113.30
NON COM.      X10649.35    Non-commission
                          sales amount
    
```

• Sample Z report

```

31/08/01 23:02      11
123456 #1681      MAVER
11 NILS

#141 XZ1X
X CLERK X
    
```

The subsequent printout occurs in the same format as in the sample X report.

Full clerk reading and resetting

```

31/08/01 22:38      11
123456 #1666      MAVER
11 NILS

#140 X<1X
X CLERK X
    
```

```

31/08/01 22:39      11
123456 #1667      MAVER
11 NILS

#140 XZ1X
X CLERK X
    
```

The subsequent printout occurs in the same format as in the reports of individual clerk reading and resetting, and sales data for clerks print in this sequence.

* When you take these reports in the OP X/Z mode, the X report shows an "OP X" and the Z report shows an "OP Z".

■ Reading and resetting of hourly sales information

You can take X and Z reports for sales totals and transaction (customer) counters for 48 half hours, or 24 hours. If both quantity and amount are zero, their print is skipped.

• Sample X report

```

31/08/01 21:57      11
123456 #1652  MAVER
12 BETH

#160 XZ1X
% HOURLY %
  7:00              0 Q
                   X0.00
AVE.                X0.00
  7:30              2 Q
                   X64.50
AVE.                X32.25
SUBTOTAL            2 Q
                   X64.50

  8:00              5 Q
                   X72.50
AVE.                X14.50
  8:30              3 Q
                   X76.15
AVE.                X25.38
SUBTOTAL            8 Q
                   X148.65
    
```

• Sample Z report

```

31/08/01 21:58      11
123456 #1653  MAVER
12 BETH

#160 XZ1X
% HOURLY %
    
```

The subsequent printout occurs in the same format as in the sample X report.

```

  17:00             3 Q
                   X21.00
AVE.                X7.00
  17:30             11 Q
                   X277.41
AVE.                X25.22
SUBTOTAL            14 Q
                   X298.41

  18:00             9 Q
                   X75.72
AVE.                X8.41
  18:30             11 Q
                   X196.80
AVE.                X17.89
SUBTOTAL            20 Q
                   X272.52
    
```

— Customer counter
— Sales total
— Average sales amount per customer
(sales total ÷ customer counter)

■ Full department reading

```

31/08/01 20:56      11
123456 #1622  MAVER
12 BETH

#110 X<1X
XDEPTX
D01      126.563 Q
PL000001  X638.51
          4.66%
D04      17.000 Q
DPT.04   X670.45
          4.90%
D05      61.000 Q
DPT.05   X11314.11
          82.66%
    
```

} Sales q'ty and total
 Ratio of dept. 1 sales
 amount to "+"
 dept. total

```

D09      28.500 Q
DPT.09   X83.80
          0.61%
GROUP01  337.063 Q
          X13687.81
          52.82%

D02      357.000 Q
DPT.02   X10930.25
          100.00%
GROUP02  357.000 Q
          X10930.25
          42.18%

XDEPT TL 757.063 Q
          X25915.09
          100.00%

D10      3.000 Q
DPT.10   -35.00
DEPT(-)  3.000 Q
          -35.00

D11      30.000 Q
DPT.11   X1.50
XHASH TL 30.000 Q
          X1.50
    
```

```

D12      2.000 Q
DPT.12   X16.50
D15      4.000 Q
DPT.15   -1.08
HASH(-)  6.000 Q
          X15.42

D13      7.000 Q
DPT.13   -60.00
XB TTL TL 7.000 Q
          -60.00

D14      7.000 Q
DPT.14   X505.26
BTTL(-)  7.000 Q
          X505.26
    
```

■ Individual group reading

31/08/01 21:02	11	
123456 #1623	MAVER	
12 BETH		
#112 X<1X		
% GROUP %		
D01	126.563 Q	
PL000001	%639.51	
D04	17.000 Q	
DPT.04	%670.45	
D05	61.000 Q	
DPT.05	%11314.11	
D06	22.000 Q	
DPT.06	%350.65	
D07	32.000 Q	
DPT.07	%437.00	
D08	50.000 Q	
DPT.08	%193.29	
D09	28.500 Q	
DPT.09	%83.80	
GROUP01	337.063 Q	} Group 1 sales q'ty and total
	%13687.81	

■ Full group reading

31/08/01 21:03	11	
123456 #1624	MAVER	
12 BETH		
#113 X<1X		
% GROUP %		
GROUP01	337.063 Q	} Group 1 sales q'ty and total
	%13687.81	
	52.82%	
GROUP02	357.000 Q	
	%10930.25	
	42.18%	
XDEPT TL	757.063 Q	
	%25915.09	
	100.00%	
DEPT(-)	3.000 Q	
	-35.00	
XHASH TL	30.000 Q	
	%1.50	
HASH(-)	6.000 Q	
	%15.42	
XBTTL TL	7.000 Q	
	-60.00	
BTTL(-)	7.000 Q	
	%505.26	

■ Reading and resetting of sales information for a range of PLUs/subdepartments

This function provides you with X and Z reports for sales information of a certain range of PLUs/subdepartments. You must enter the start and end PLU/subdepartment code of the range. Of course, the range may represent all of the PLUs/subdepartments in your register.

• Sample X report

31/08/01 20:30		11	
123456 #1612		MAVER	
12 BETH			
#120 XZLX			
X PLU X			
	000001-999999		Range
PLU code	F000001	118.000 Q	Sales q'ty and total
Item label	PL000001	¥691.75	
	F000002	7.000 Q	
	PL000002	¥10.50	
	F000003	1.000 Q	
	PL000003	¥0.00	
	F000006	3.063 Q	
	PL000006	¥18.38	
	F000008	9.500 Q	
	PL000008	¥40.75	
	F000010	19.000 Q	
	PL000010	¥114.40	
	F000011	5.000 Q	
	PL000011	¥60.00	
	F000080	3.000 Q	Range sum
	PL000080	¥21.50	
	F000090	2.000 Q	
	PL000090	¥10.38	
	***TOTAL	265.063 Q	
		¥1262.69	

• Sample Z report

31/08/01 23:45		11
123456 #1684		MAVER
#120 XZLX		
X PLU X		

The subsequent printout occurs in the same format as in the sample X report.

■ Reading of sales information on PLUs/subdepartments associated with an individual department

31/08/01 21:05 11		
123456 #1625 MAVER		
12 BETH		
#121 *X1*		
* PLU *		
PLU code	PL000001	DO1
	F000006	3.063 Q
	PL000006	*18.38
	F000010	19.000 Q
	PL000010	*114.40
	F000021	8.000 Q
	PL000021	*28.00
	F000080	3.000 Q
	PL000080	*21.50
	F000090	2.000 Q
	PL000090	*10.38
	***TOTAL	99.563 Q
		*411.36

Associated dept. code

Sales q'ty and total

■ Reading of PLU/subdepartments whose sales amounts are zeros (by associated department)

31/08/01 21:06 11		
123456 #1267 MAVER		
12 BETH		
#127 *X1*		
* PLU *		
ZERO SAL		
	DPT.01	DO1
	F000009	
	PL000009	

Associated dept. code

■ Reading of PLUs/subdepartments whose sales amounts are zeros

31/08/01 21:05 11		
123456 #1266 MAVER		
12 BETH		
#127 *X1*		
* PLU *		
ZERO SAL		
	F000009	
	PL000009	
	F000012	
	PL000012	
	F000014	
	PL000014	

PLU code

Item label

■ Reading of sales information for the price amount range of PLUs/subdepartments

31/08/01 21:15 11		
123456 #1629 MAVER		
12 BETH		
#129 *X1*		
CATEGORY		
		0.00 - 9999.99
	F000001	122.000 Q
	PL000001	*727.25
	F000002	7.000 Q
	PL000002	*10.50
	F000003	1.000 Q
	PL000003	*0.00
	F000006	3.063 Q
	PL000006	*18.38
	F000080	3.000 Q
	PL000080	*21.50
	F000090	2.000 Q
	PL000090	*10.38

Price amount range

Sales q'ty and total

■ Reading and resetting of sales information for EANs

• Sample X report

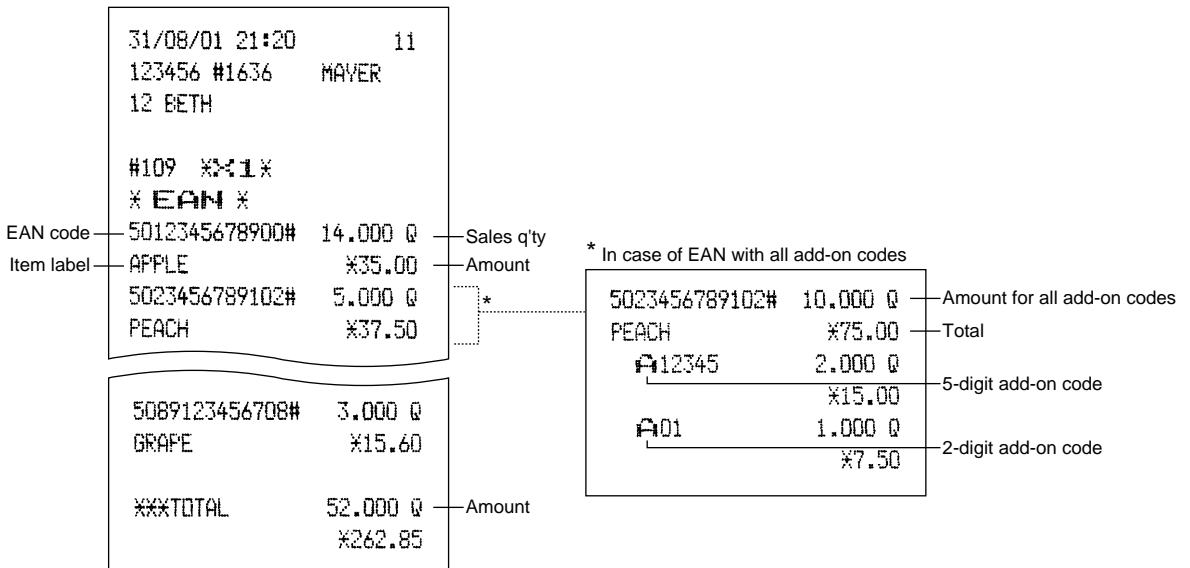

• Sample Z report

31/08/01 21:46	11		
123456 #1655		MAVER	
12 BETH			
#109	%Z1%		
* EAN *			

The subsequent printout occurs in the same format as in the sample X report.

Note The EAN codes are printed out in the sequence shown below.

EAN-13
EAN-8
In-store marking PLU short type
In-store marking Non-PLU short type
UPC-A
UPC-E

■ Reading and resetting of sales information for EANs associated with an individual department

• Sample X report

	31/08/01 21:25	11	
	123456 #1640		MAYER
	12 BETH		
	#101 *X1*		
	* EAN *		
	DPT.01		DO1
EAN code	5012345678900#	14.000 Q	
Item label	APPLE	*35.00	
	5023456789102#	5.000 Q	
	PEACH	*37.50	
	5056789123404#	14.000 Q	
	BANANA	*105.00	
	5087654321106#	1.000 Q	
	ORANGE	*6.00	
	5089123456708#	3.000 Q	
	GRAPE	*15.60	
	***TOTAL	37.000 Q	
		*199.10	

Associated dept. code

Sales q'ty and total

• Sample Z report

	31/08/01 21:46	11	
	123456 #1656		MAYER
	12 BETH		
	#101 *Z1*		
	* EAN *		
	DPT.01		DO1

The subsequent printout occurs in the same format as in the sample X report.

■ Reading of EANs whose sales amounts are zeros

	31/08/01 21:26	11	
	123456 #1641		MAYER
	12 BETH		
	#107 *X1*		
	* EAN *		
	ZERO SAL		
	5045678912304#		
	ONION		
	5067891234506#		
	CHERRY		
	5078912345606#		
	RADISH		
	5099887654302#		
	MANGO		

■ Reading of EANs whose sales amounts are zeros (by associated department)

	31/08/01 21:26	11	
	123456 #1642		MAYER
	12 BETH		
	#107 *X1*		
	* EAN *		
	ZERO SAL		
	DPT.01		DO1
	5067891234506#		
	CHERRY		
	5099887654302#		
	MANGO		

Associated dept. code

■ Reading of commission sales information

31/08/01 22:35	11	
123456 #1663		MAYER
12 BETH		
#132	%<1%	
% SALES	%	
COM.SAL1	¥2139.15	Commission sales 1 amount total
COM.SAL2	¥11262.11	
COM.SAL3	¥187.00	
COM.SAL4	¥50.20	
COM.SAL5	¥113.45	
COM.SAL6	¥35.00	
COM.SAL7	¥92.56	
COM.SAL8	¥53.85	
COM.SAL9	¥125.51	
NON COM.	¥13268.11	Non-commission sales amount
NET 1	¥26866.34	

■ Total in drawer reading

31/08/01 21:43	11	
123456 #1643		MAYER
12 BETH		
#131	%<1%	
% TL-ID	%	
EXCH1	5 Q	Exchange 1 counter
	DM397.00	Currency exchange 1 total
DDM.CUR1	¥220.28	Domestic currency for currency exchange 1 total
EX1 CHK	1 Q	
	DM50.00	
DDM.CUR1	¥25.56	
EX1 CR	2 Q	
	DM95.06	
DDM.CUR1	¥48.60	
EXCH2	1 Q	
	23.47	
DDM.CUR2	¥12.00	
EXCH3	1 Q	
	45.08	
DDM.CUR3	¥23.00	
EXCH4	2 Q	
	140.00	
DDM.CUR4	¥123.93	
***CID	¥1451.40	Cash in drawer
XCH ID	¥166.56	Cheque in drawer
CA/CH ID	¥1617.96	Cash/Cheque in drawer

■ Transaction reading

31/08/01 21:44	11	
123456 #1644		MAYER
12 BETH		
#130	%<1%	
% TRANS.	%	

In this report the same transaction data as those printed when full reading is taken are printed except department sales totals.

■ Reading and resetting of a stacked report

You can print multiple X1/Z1 reports in sequence at a time.

In this case, you need to program in advance what X1/Z1 reports should be printed in the stacked report sequence.

Note

The following job code numbers alone can be used for stacked report printing.

Job code number: 100, 107, 109, 110, 113, 120, 127, 129, 130, 131, 132, 140, 150, 160

Refer to "Selection of X1/Z1 and X2/Z2 reports to be printed in the stacked report sequence" for details.

■ Deleting of non-accessed EANs

• Sample X report (Reading)

	26/08/01 21:47	11
	123456 #1658	MAVER
	12 BETH	
	#105 %X1%	
	* EAN *	
	NO ACCES	
EAN code	5089123456708#	0.000 Q
Item label	GRAPE	%0.00
	%Z2%	5.000 Q
		%26.00

Periodic sales*

• Sample Z report (Deleting)

	26/08/01 21:49	11
	123456 #1659	MAVER
	12 BETH	
	#105 %Z1%	
	* EAN *	
	NO ACCES	

The subsequent printout occurs in the same format as in the sample X report.

*: When there is any sales data of the EAN for #209 report, the data is printed here.

When you delete the EAN in Z1 mode under the this situation, the data for #209 is also deleted.

4 Periodic consolidation

Your register allows you to take consolidation X and Z reports of a chosen period (normally one week or a month).

■ Generality

The periodic reading or resetting reports are the same in format as those in the X1/Z1 report for daily total except job code no. (#2xx) and mode indication ("X2" or "Z2".)

• Sample X report

```
02/09/01 21:49      11
123456 #1692  MAVER
11 NILS

#200 X342X
```

Read symbol

• Sample Z report

```
02/09/01 21:53      11
123456 #1816  MAVER
11 NILS

#200 XZ2X
                Z1 0005
                Z2 0003
GT1  X00000057632.95
GT2  X00000066847.69
GT3  -00000009214.74
TR   X00000000318.65
```

Reset symbol
Reset counter of daily total
Reset counter of periodic consolidation
Grand total

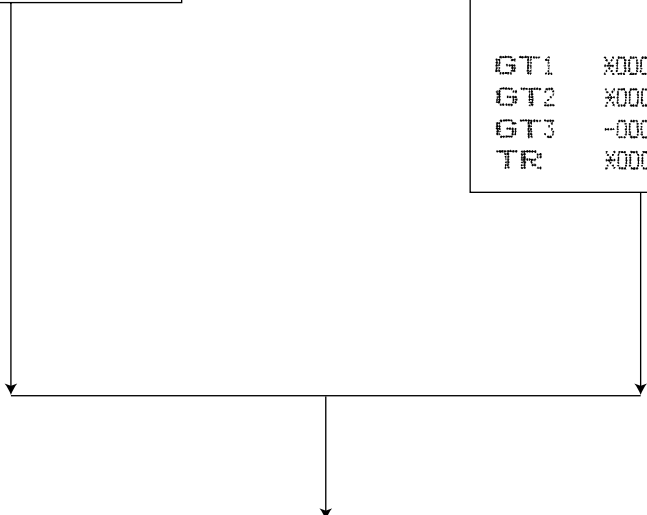

The subsequent printouts are the same in format as those in the X/Z report for daily total.

■ Reading and resetting of the daily net totals

31/08/98 20:46	11
123456 #1894	MAVER
11 NILS	
#270 X342%	
% DAILY %	
01/08	89 0
	X5385.03
02/08	92 0
	X5335.00
03/08	102 0
	X5056.77
04/08	98 0
	X4989.25
05/08	84 0
	X5681.50
29/08	81 0
	X5031.41
30/08	91 0
	X4897.25
XXXTOTAL	2047 0
	X152851.21

31/08/01 20:58	11
123456 #1904	MAVER
11 NILS	
#270 XZZ%	

↓
The subsequent printout occurs in the same format as in the sample X report.

■ Reading and resetting of a stacked report

You can print multiple X1/Z1 reports in sequence at a time.

In this case, you need to program in advance what X1/Z1 reports should be printed in the stacked report sequence.

Note

The following job code numbers alone can be used for stacked report printing.

Job code number: 200, 207, 209, 210, 213, 220, 227, 229, 230, 231, 232, 240, 250, 270

Refer to "Selection of X1/Z1 and X2/Z2 reports to be printed in the stacked report sequence" for details.

COMPULSORY CASH/CHEQUE DECLARATION

If you want to make mandatory the declaration of the cash and cheque amount in the drawer before outputting cashier Z reports, consult your dealer and have your register programmed for compulsory cash/cheque declaration.

If your register is programmed for compulsory cash/cheque declaration (CCD), a cashier must first count and declare the cash and cheque amounts (of domestic and foreign currency) in the drawer, before he or she can output a cashier report. The procedure for outputting a CCD report is shown below.

Types of compulsory cash/cheque declaration

- Compulsory declaration prior to individual cashier resetting
- Compulsory declaration prior to full cashier resetting

Note

- Compulsory cash/cheque declaration is available in the above two types. You can choose either of these. Consult your dealer for details.
- When cash/cheque declaration is compulsory, flash reports are not available.

Key operation

After the first **TL** key is pressed, the register prompts the cashier to input the cash and cheque accounts for both domestic and foreign currency. The cashier can simply input the total amounts of each currency unit, or the number of bills or coins of each denomination of each currency unit.

Individual cashier report

OP X/Z mode



X1/Z1 mode



Full cashier report

X1/Z1 mode



The drawer opens and the cashier is prompted to enter the cash and cheque amounts. ("£" is displayed.)

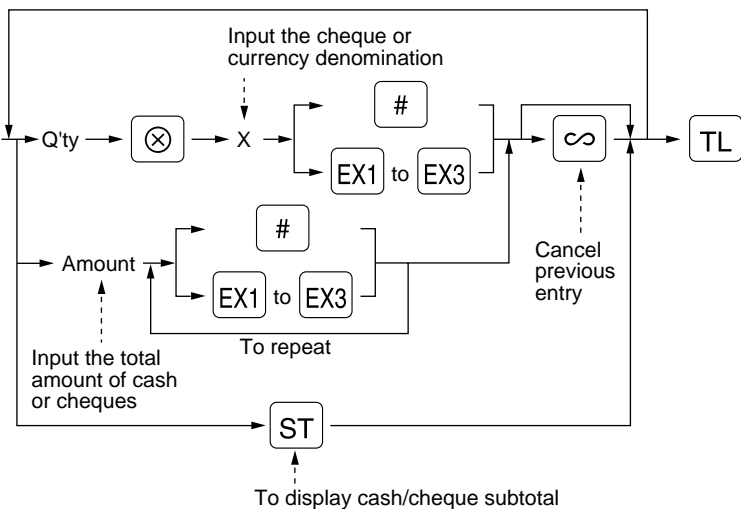

[#] :When inputting the cash or cheque amount (domestic currency) in the drawer

[EX1] to [EX3] :When inputting the amount of a foreign currency in the drawer

```

01/09/01 20:16      11
123456 #1728  MAVER
01 NILS

#151 *Z1*
* CCD *
CA/CH IS           *967.70
EXCH1 IS           150.00
EXCH2 IS           50.00

XCASHIER *
                Z1 0004
01CSR#111  MAVER
ORDER TL          *1220.50
PAID TL          *1220.50
AVE.             *71.79

```

} CCD entry amount

```

                *50.00
EXCH1           1 Q
                150.00
EXCH1 IS       150.00
CCD DIF.       0.00
DDM.CUR1      *76.69
EX1 CHK       1 Q
                50.00
DDM.CUR1      *25.56
EX1 CR        1 Q
                71.39
DDM.CUR1      *36.50
EXCH2         1 Q
                50.00
EXCH2 IS      50.00
CCD DIF.      0.00
DDM.CUR2      *49.05
EXCH3         0 Q
                0.00
EXCH3 IS      0.00
CCD DIF.      0.00
DDM.CUR3      *0.00

XXXXCID       *873.70
XCH ID        *94.00
CA/CH ID      *967.70
CA/CH IS      *967.70
CCD DIF.      *0.00
DIF. TL       *0.00
CHK/CG        *0.56

```

— Currency exchange 1 cash in drawer to be obtained
— Total of entered (declared) exchange 1 in drawer
— Difference

— Cash in drawer to be obtained
— Cheque (in domestic currency) in drawer to be obtained
— Cash/cheque in drawer to be obtained
— Total of entered (declared) cash/cheque in drawer
— Difference
— Total of difference
— Change total for cheque tendering

PROGRAMMING FOR EURO

Your register can be modified to correspond with each period set for the introduction of EURO, and in your register each currency is treated as shown on the table below depending on which period you are in. Basically your register can be automatically modified to correspond to the introduction of EURO by executing the operation of Job #800 in X2/Z2 mode. However, there are several options you must set depending on your needs.

How currencies are treated in your register

	Period 1	Period 2	Period 3
	After the introduction of EURO, and before EURO banknotes and coins begin to circulate	After EURO banknotes and coins begin to circulate, and before national currency is withdrawn from circulation. (Co-existence of EURO and national currency)	After the national currency is withdrawn from circulation
Currency	EURO	Exchange 1	Domestic currency
	National currency (DM, F, etc.)	Domestic currency	Exchange 1
	Foreign currency	Exchange 2 to Exchange 4	Exchange 2 to Exchange 4

Receipt samples:

Period 1

DPT.01	¥1.00
DPT.02	¥2.00
***TOTAL	¥3.00
	€1.53
CASH	¥5.00
CHANGE	¥2.00
	€1.02

- Sales total amount in national currency (as domestic currency)
- Sales total amount in EURO*
- Tendered amount in national currency
- Change in national currency
- Change in EURO*

*: They are printed for information purposes only.

Period 2

DPT.01	€0.51
DPT.02	€1.02
***TOTAL	€1.53
	¥2.79
CASH	€2.00
CHANGE	€0.47
	¥0.92

- Sales total amount in EURO (as domestic currency)
- Sales total amount in national currency*
- Tendered amount in EURO
- Change in EURO
- Change in national currency*

*: They are printed for information purposes only.

Period 3

DPT.01	€0.51
DPT.02	€1.02
***TOTAL	€1.53
CASH	€2.00
CHANGE	€0.47

■ Automatic modification of register system for introduction of EURO

X2/Z2

800

To make your register correspond to the introduction of EURO, your register system can be automatically modified when the procedure shown below is executed in the X2/Z2 mode. According to the steps of the introduction, you can make your register correspond to EURO.

Procedure

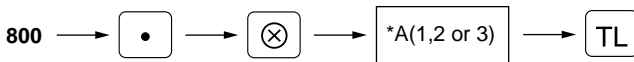

*A=1: Applicable for the period 1

*A=2: Applicable for the period 2

*A=3: Applicable for the period 3

Note

• You can perform the each operation only once with the substitution of "A=1", "A=2" and "A=3". If you performed the operation with the substitution of "A=2" first, you cannot perform the operation with the substitution of "A=1". If you performed the operation with the substitution of "A=3" first, you cannot perform the operation with the substitution of "A=1" and "A=2".

The details of the register system modification are as follows:

When "1" is substituted to "A":

1. Issuing a general Z1 report (Job #100)
2. Issuing a general Z2 report (Job #200)
3. Setting "Yes" for a PGM function "Printing exchange 1 total amount and change amount on receipt and journal" (Job #2616)
4. Setting "Yes" for a PGM function "Printing exchange 1 total amount on validation printing" (Job #2616)
5. Setting "Division" for a PGM function "Exchange 1 calculation method" (Job #2616)
6. Setting the EURO symbol (€) for the currency description text (Job #2334), and setting "2" for the number of digits after decimal point (Job #2330) of exchange 1
7. Setting the round-off function enable for currency exchange

After the execution of the procedure with the substitution of "1", treat EURO as foreign currency using Exchange 1 (EX1).

When "2" is substituted to "A":

1. Issuing a general Z1 report (Job #100)
2. Issuing a general Z2 report (Job #200)
3. Resetting GT1, GT2, GT3 and training GT
4. Converting the unit prices of Dept, PLU and EAN to EURO currency.
5. Setting "Yes" for a PGM function "Printing exchange 1 total amount and change amount on receipt and journal" (Job #2616)
6. Setting "Yes" for a PGM function "Printing exchange 1 total amount on validation printing" (Job #2616)
7. Setting "Multiplication" for a PGM function "Exchange 1 calculation method" (Job #2616)
8. Changing the domestic currency symbol to the EURO symbol (€) and setting the number of digits after decimal point of the domestic currency to 2
9. For the setting of the currency description text and the number of digits after decimal point of exchange 1, the ones that had been set to the domestic currency are set. (Job #2330 and #2334)
10. Setting the round-off function enable for currency exchange

Note

When any special setting has been applied for the rounding system to make it suit your domestic (national) currency, the setting is cancelled to make it suit your new domestic currency, EURO.

After the execution of the procedure with the substitution of “2”, treat EURO as domestic currency, and national currency as foreign currency using Exchange 1 (EX1).

With the execution of the procedure with the substitution of “2”, your domestic currency becomes EURO. While unit prices of departments, PLUs and EANs are automatically converted to EURO currency, you must change the rates or amounts for the miscellaneous keys so that they are based on amounts in EURO.

When “3” is substituted to “A”:

1. Issuing a general Z1 report (Job #100)
2. Issuing a general Z2 report (Job #200)
3. Resetting GT1, GT2, GT3 and training GT
4. Converting the unit prices of Dept, PLU and EAN to EURO currency.
5. Setting “No” for a PGM function “Printing exchange 1 total amount and change amount on receipt and journal” (Job #2616)
6. Setting “No” for a PGM function “Printing exchange 1 total amount on validation printing” (Job #2616)
7. Setting “Multiplication” for a PGM function “Exchange 1 calculation method” (Job#2616)
8. Changing the domestic currency symbol to the EURO symbol and setting the number of digits after decimal of the domestic currency to 2
9. Setting the round-off function enable for currency exchange

Note *When the operation is performed from the status of substitution “1”, and when any special setting has been applied for the rounding system to make it suit your domestic (national) currency, the setting is cancelled to make it suit your new domestic currency, EURO.*

After the execution of the procedure with the substitution of “3”, treat EURO as domestic currency.

When the operation with the substitution of “2” has been performed already, “3. Resetting GT1, GT2, GT3 and training GT” is not executed.

When the operation with the substitution of “1” or “2” has been performed already, the currency symbol of exchange key is overwritten with a space.

■ Optional programming for the introduction of EURO PGM 1 PGM 2

Programming relating with the function of exchange 1 (EX1) cannot be changed automatically with the execution of Job #800 described in the previous section. After the execution on each period, conduct the following programming depending on your needs.

Programming for Exchange 1 (EX1)

Currency exchange rate (Job #1310)

For the period 1 and period 2, set the EURO conversion rate.

Cheque/credit operation (Job #2616)

Assigning the drawer number to the drawer for foreign currency (Job #2680)

It may be convenient to have two drawers for EURO (as domestic currency) and national currency (as the foreign currency set in exchange 1) when both of these currencies are co-existing (period 2). In this case, conduct this programming.

OVERRIDE ENTRIES

Programmed limit for functions (such as for maximum amounts) can be overridden by making an entry in the MGR mode.

Procedure

1. Turn the mode switch to the MGR position.
2. Make an override entry.

Example

On this example, the register has been programmed not to allow deduction entries over 2.00.

Key operation	Print
1500 <input type="text" value="2"/>	
REG-mode 250 <input type="text" value="⊖"/> ...Error	DPT.02 ¥15.00
entries <input type="text" value="CL"/>	⟨-⟩1 -2.50
Turn the mode switch to the MGR position.	CASH ¥12.50
250 <input type="text" value="⊖"/>	
Return the mode switch to the REG position.	
<input type="text" value="TL"/>	

CORRECTION AFTER FINALIZING A TRANSACTION (AFTER GENERATING A RECEIPT)

When you need to void incorrect entries that cashiers cannot correct (incorrect entries that are found after finalizing a transaction or cannot be corrected by direct or indirect void), follow this procedure in the MGR mode.

1. Turn the mode switch to the MGR position.
2. Press the  key to put your register in the VOID mode.
3. Repeat the entries that are recorded on an incorrect receipt. (All data for the incorrect receipt are removed from register memory; the voided amounts are added to the void register totalizer.)

Incorrect receipt

```
31/08/01 15:31      11
123456 #1411  MAYER
11 NILS

DPT.02          ¥10.00
DPT.03          ¥1.50

CASH           ¥11.50
```



Cancellation receipt

```
31/08/01 15:33      11
123456 #1412  MAYER
11 NILS

¥10 MODEX
DPT.02          ¥10.00
DPT.03          ¥1.50

CASH           ¥11.50
```

Note

Your machine leaves the VOID mode whenever a transaction is canceled (i.e. finalized in the VOID mode.) To void additional transactions repeat steps 2. and 3. above.

PRIOR TO ENTRIES

1 Preparations for entries

Before registrations, insert the operator key into the mode switch and turn it to the REG position and check the following items:

■ Receipt and journal paper rolls

If the receipt and journal paper rolls are not set in the machine or there are low rolls, install new ones according to section "4. Installing and removing the paper rolls" under "OPERATOR MAINTENANCE."

■ Receipt ON/OFF function

You can disable receipt printing in the REG mode to save paper using the receipt function. To disable receipt printing, press the **RCPT** key in the OP X/Z position. This key toggles the receipt printing status ON and OFF. To check the receipt printing status, turn the mode switch to the OP X/Z position or press the **CL** key in the REG mode. When the function is in the OFF status, the receipt off indicator "_" illuminates.

Note Your register will print reports regardless of the receipt state. This means that the receipt roll must be installed even when the receipt state is "OFF".

■ Cashier and clerk assignment

Prior to any item entries, cashiers must enter their cashier codes into the register, and may also be required to enter a clerk code. However, these code entries may not be necessary when the same cashier or clerk code is used in the next transaction.

Cashier codes and clerk codes are available in two variants: Variant 1, in which they are displayed ("-00-" to "-99-"), and Variant 2, in which they are not displayed (always "-00-").

When the cashier or clerk code is assigned by the following procedure, the register prints the two-digit cashier code or clerk code (variant 2: "★★") and the cashier or clerk name both on the receipt and journal for every transaction.

Note All of these settings depend on how the register has been programmed. For the selection of these settings, consult your local dealer.

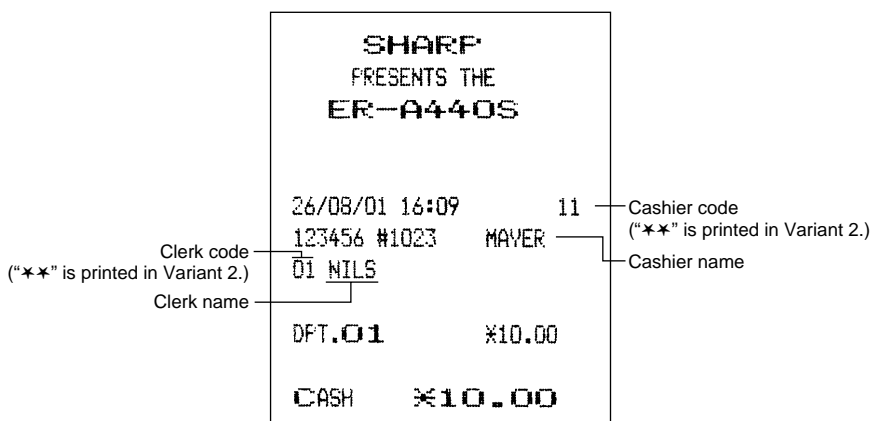

Procedure

Cashier assignment

■ Sign-on

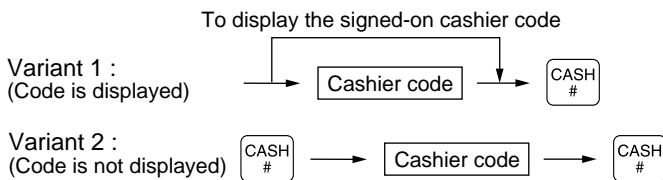

■ Sign-off

Variant 1 / Variant 2 :

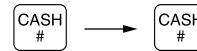

Note

The real cashier key system is also available. In this system put one of the 1 through 15 keys in the cashier switch to sign on. If you want to choose this system, consult your dealer.

Clerk assignment

■ Sign-on

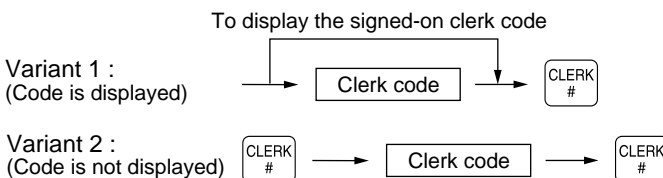

■ Sign-off

Variant 1 / Variant 2 :

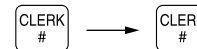

Note

- On the current factory setting, only the entry of the cashier code is required. When cashier & clerk codes entries are desirable for your register, consult your dealer.
- If you want to enter cashier and/or clerk codes before every transaction, consult your dealer.
- For the display type selection of cashier code and clerk code, "Variant 1" has been preset. For the selection of "Variant 2," consult your dealer.
- Clerk can be changed during the transaction. Consult your dealer.

2 Error warning

In the following examples, your register will go into an error state accompanied with a warning beep and the error symbol "E" on the display. Clear the error state by pressing the **CL** key and take proper action. Please refer to the error code table on page 158.

- When you enter an over 32-digit number (entry limit overflow): Cancel the entry and re-enter a correct number.
- When you make an error in key operation: Clear the error and continue operation.
- When you make an entry beyond a programmed amount entry limit: Check to see if the entered amount is correct. If it is correct, it can be rung up in the MGR mode. Contact your manager.
- When an including-tax subtotal exceeds eight digits: Delete the subtotal by pressing the **CL** key and press the **TL**, **CA2**, **CH1** through **CH4**, or **CR1** through **CR4** key to finalize the transaction.

ENTRIES

1 Item entries

Single item entries

Procedure

Department entries (direct department entries)

Enter a unit price and press a department key. If you use a programmed unit price, press a department key only.

When using a programmed unit price

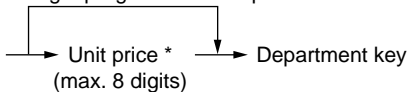

*Less than the programmed upper limit amounts

Note

When those departments for which the unit price has been programmed as zero (0) are entered, only the sales quantity is added.

Department entries (indirect department entries)

When using a programmed unit price

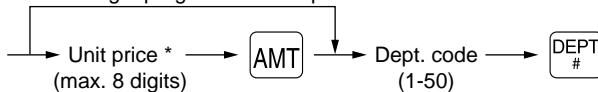

*Less than the programmed upper limit amounts

PLU entries (indirect PLU entries)

Enter a PLU code and press the **PLU/SUB** key.

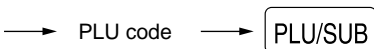

Note

When those PLUs for which the unit price has been programmed as zero (0) are entered, only the sales quantity is added.

Subdepartment (open PLU) entries

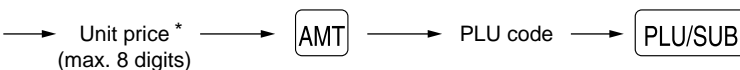

*Less than the programmed upper limit amounts

PLU entries (direct PLU entries)

When using a programmed price

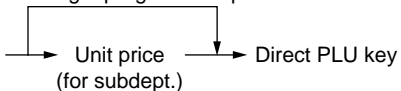

EAN entries

Scan EAN code

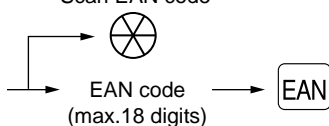

* After scanning a EAN code or pressing the **EAN** key, you may be requested to enter a unit price with the display "-----". In this case, enter the price and press the **AMT** key.

Example

Key operation

1200 [3]
 [5]
 8 [DEPT #]
 680 [AMT] 5 [DEPT #]
 2 [PLU/SUB]
 1200 [AMT] 11 [PLU/SUB]
 [8]
 5012345678900 [EAN]
 [TL]

Print

```
DPT.03      ¥12.00
DPT.05      ¥5.00
DPT.08      ¥2.00
DPT.05      ¥6.80
PL000002    ¥1.50
PL000011    ¥12.00
PL000008    ¥3.50
5012345678900#
APPLE      ¥2.50

CASH      ¥45.30
```

Repeat entries

You can use this function for entering a sale of two or more same items.

You can use the [REPEAT] key to repeat entry instead of department, [DEPT #], direct PLU, [PLU/SUB] or [EAN] key.

Example

Key operation

Repeated department entry (direct) { 200 [8]
 [8]
 [8]
 Repeated department entry (indirect) { 680 [AMT] 5 [DEPT #]
 [DEPT #]
 Repeated PLU entry (indirect) { 10 [PLU/SUB]
 [PLU/SUB]
 [PLU/SUB]
 Repeated PLU entry (direct) { [51]
 [51]
 Repeated subdepartment entry { 500 [AMT]
 60 [PLU/SUB]
 [PLU/SUB]
 Repeated EAN entry { 5012345678900 [EAN]
 [EAN]
 Repeated department entry (direct) using the repeat key { 600 [2]
 [REPEAT]
 [REPEAT]
 [TL]

Print

```
DPT.08      ¥2.00
DPT.08      ¥2.00
DPT.08      ¥2.00
DPT.05      ¥6.80
DPT.05      ¥6.80
PL000010    ¥7.15
PL000010    ¥7.15
PL000010    ¥7.15
PL000051    ¥2.80
PL000051    ¥2.80
PL000060    ¥5.00
PL000060    ¥5.00
5012345678900#
APPLE      ¥2.50
5012345678900#
APPLE      ¥2.50
DPT.02      ¥6.00
DPT.02      ¥6.00
DPT.02      ¥6.00

CASH      ¥79.65
```

■ Multiplication entries

Use this feature entry method when you need to enter two or more same items.

This feature helps when you sell a large quantity of items or need to enter quantities that contain decimals.

Procedure

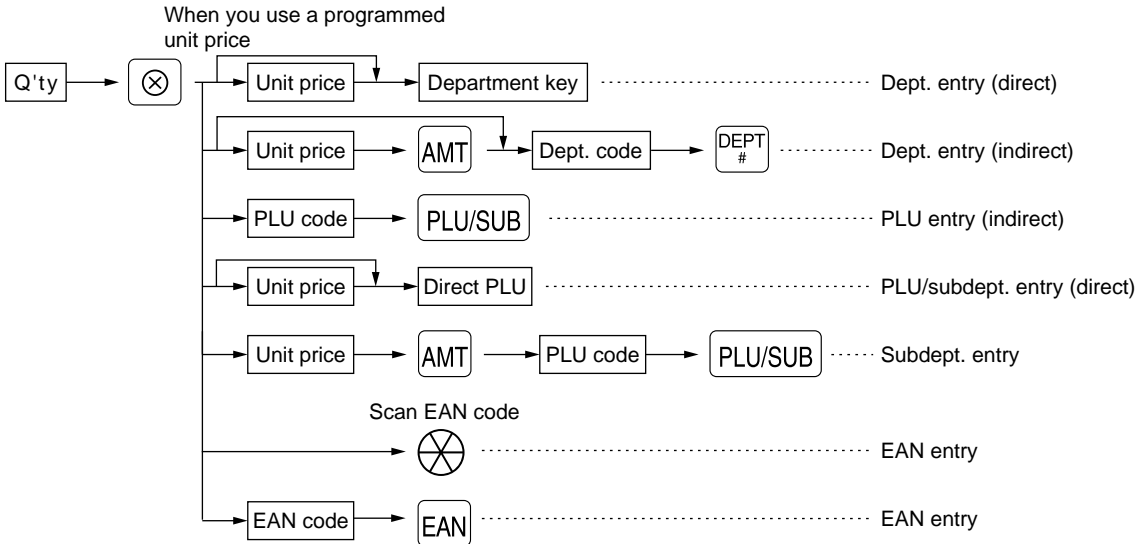

- After scanning an EAN code or pressing the **[EAN]** key, you may be requested to enter a unit price with the display "-----". In this case, enter the unit price and press the **[AMT]** key.
- Q'ty: Up to four digits integer + three digits decimal
- Unit price: Less than a programmed upper limit
- Q'ty x unit price: Up to eight digits

Example

Key operation

Department entry (direct)	{	7	.	5	⊗
		165		8	
Department entry (indirect)	{	2		⊗	
		250		AMT	
		5		DEPT #	
PLU entry	{	15		⊗	
		13		PLU/SUB	
Direct PLU entry	{	8	.	25	⊗
				58	
Subdepartment entry	{	3		⊗	
		100		AMT	
		60		PLU/SUB	
EAN entry	{	5		⊗	
		5012345678900		EAN	
				TL	

Print

7.5x 1.65	
DPT.08	¥12.38
2x 2.50	
DPT.05	¥5.00
15x 2.10	
PL000013	¥31.50
8.25x 3.00	
PL000058	¥24.75
3x 1.00	
PL000060	¥3.00
5x 2.50	
5012345678900#	
APPLE	¥12.50
CASH	¥89.13

■ Successive multiplication entries

This function is practical for example when you enter a sale of items sold by area (square meter).

Procedure

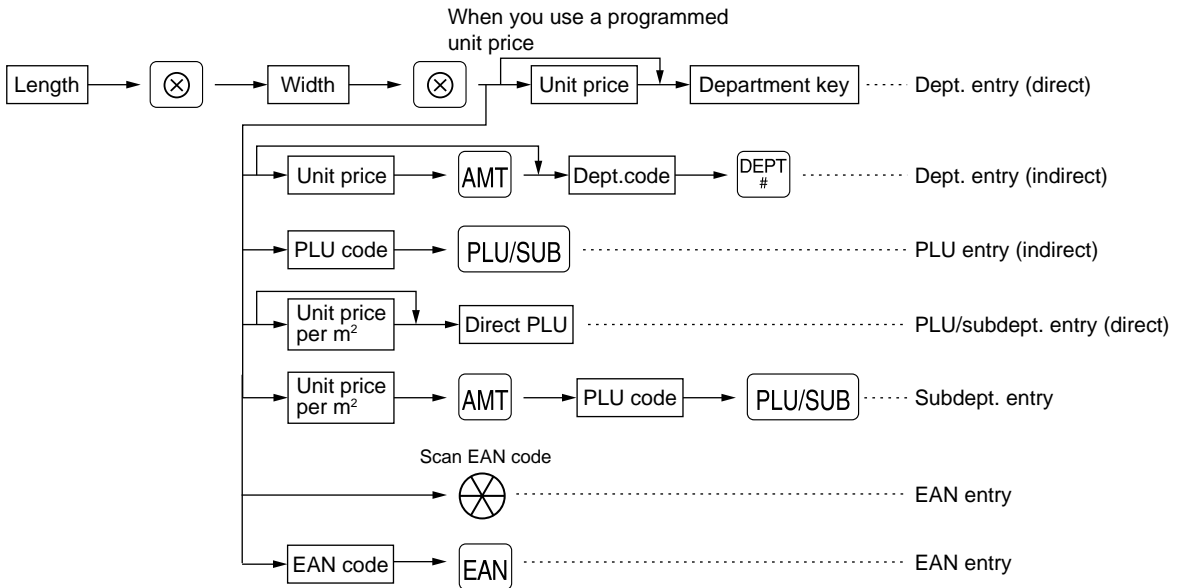

- After scanning an EAN code or pressing the **[EAN]** key, you may be requested to enter a unit price with the display "-----". In this case, enter the unit price and press the **[AMT]** key.
- Length or width: up to seven digits (4-digit integer + 3-digit decimal)
- Unit price: less than a programmed upper limit
- Length x Width x Unit price: up to eight digits

Note For actual use of this function, consult your dealer.

Example

	Key operation	Print
Department entry	3 [⊗]	<pre> 3x 4x 4.00 DPT.05 ¥48.00 1.5x 2.5x 3.00 PL000008 ¥11.25 1.75x 1.75x 6.00 PL000006 ¥18.38 4x 5x 5.00 5099887654302# ¥100.00 CASH ¥177.63 </pre>
	4 [⊗]	
PLU entry	400 [5]	
	1 [.] 5 [⊗]	
	2 [.] 5 [⊗]	
Subdepartment entry	8 [PLU/SUB]	
	1 [.] 75 [⊗]	
	1 [.] 75 [⊗]	
	600 [AMT]	
EAN entry	6 [PLU/SUB]	
	4 [⊗]	
	5 [⊗]	
	5099887654302 [EAN]	
	[TL]	

Split-pricing entries

You will use this function when your customer wants to purchase items normally sold in bulk.

Procedure

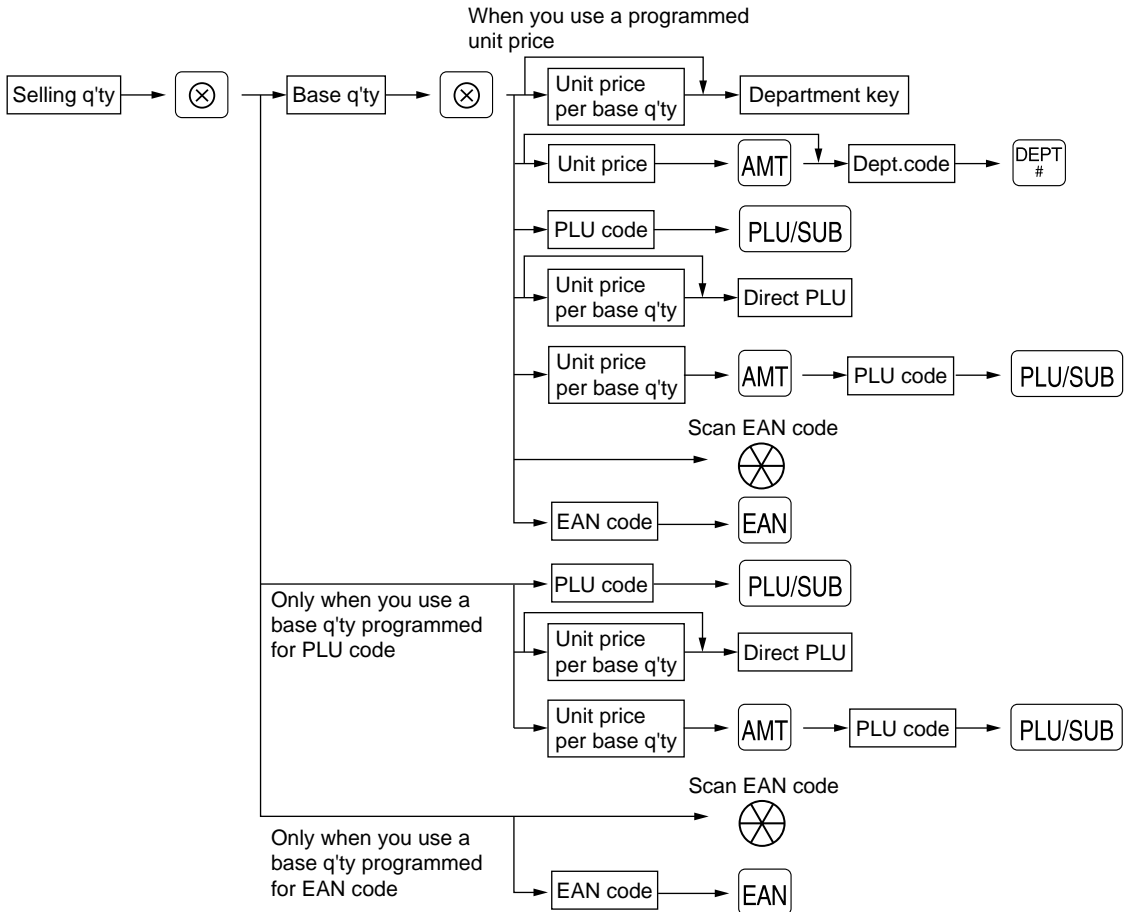

- After scanning an EAN code or pressing the **[EAN]** key, you may be requested to enter a unit price with the display "-----". In this case, enter the unit price and press the **[AMT]** key.
- Selling quantity: Up to four digits integer + three digits decimal
- Base quantity: Up to two digits (integer)

Note For actual use of this function, consult your dealer.

Example

	Key operation	Print
Department entry	7 [⊗]	7x 10/ 6.00
	10 [⊗]	
	600 [7]	
PLU entry	8 [⊗]	8x 5/ 3.00
	5 [⊗]	PL000035
	35 [PLU/SUB]	5x 6/ 8.75
EAN entry	5 [⊗]	5045678912304#
	6 [⊗]	
	5045678912304 [EAN]	
	[TL]	
		CASH ¥16.30

■ Single item cash sale (SICS)/single item finalize (SIF) entries

SICS entries

- This function is useful when a sale is for only one item and is for cash; such as a pack of cigarettes. This function is applicable only to those departments that have been set for SICS or to their associated PLUs, subdepartments or EANs.
- The transaction is finalized and the drawer opens as soon as you press the department key, DEPT # key, PLU/SUB key, the direct PLU key or EAN key.

Example

Key operation	Print				
250 For finishing → 9 the transaction	<table border="1"> <tr> <td>DPT.09</td> <td>¥2.50</td> </tr> <tr> <td>CASH</td> <td>¥2.50</td> </tr> </table>	DPT.09	¥2.50	CASH	¥2.50
DPT.09	¥2.50				
CASH	¥2.50				

Note

If an entry to a department, PLU/subdepartment or EAN set for SICS follows the ones to departments, PLUs/subdepartments or EAN not set for SICS, it does not finalize and results in a normal sale.

SIF entries

- If an entry to a department, PLU/subdepartment or EAN set for SIF follows the ones to departments or PLUs/subdepartments not set for SIF, the transaction is finalized immediately as a cash sale.
- Like the SICS function, this function is available for single-item cash settlement.

Example

Key operation	Print						
1745 8 1500 For finishing → 9 the transaction	<table border="1"> <tr> <td>DPT.08</td> <td>¥17.45</td> </tr> <tr> <td>DPT.09</td> <td>¥15.00</td> </tr> <tr> <td>CASH</td> <td>¥32.45</td> </tr> </table>	DPT.08	¥17.45	DPT.09	¥15.00	CASH	¥32.45
DPT.08	¥17.45						
DPT.09	¥15.00						
CASH	¥32.45						

■ Link PLU/EAN link entries

Operation is the same as the one for normal PLU/EAN. The print of a link PLU/EAN link entry on the receipt varies according to the PGM2 programming (#2616).

Printing detailed information

When a leading link PLU/EAN is entered, each amount and text of the leading link PLU/EAN and the linked PLUs, and their total amount are printed automatically.

Example

(In case of link PLU)

Key operation	Print												
21 PLU/SUB TL	<table border="1"> <tr> <td>PL000021</td> <td>¥3.50</td> <td rowspan="4" style="border: none; vertical-align: middle;">Linked PLUs</td> </tr> <tr> <td>PL000025</td> <td>¥3.00</td> </tr> <tr> <td>PL000026</td> <td>¥2.00</td> </tr> <tr> <td>PL000027</td> <td>¥8.00</td> </tr> <tr> <td>CASH</td> <td>¥16.50</td> <td></td> </tr> </table>	PL000021	¥3.50	Linked PLUs	PL000025	¥3.00	PL000026	¥2.00	PL000027	¥8.00	CASH	¥16.50	
PL000021	¥3.50	Linked PLUs											
PL000025	¥3.00												
PL000026	¥2.00												
PL000027	¥8.00												
CASH	¥16.50												

Printing leading link PLU/EAN and total sales amount

When a leading link PLU/EAN is entered, only the leading link PLU/EAN's text and the total sales amount (the sum of prices for the leading link PLU/EAN and the linked PLUs) are printed.

Example (In case of link PLU)

Key operation	Print						
21 PLU/SUB TL	<div style="border: 1px solid black; padding: 5px;"> <table style="width: 100%; border-collapse: collapse;"> <tr> <td style="width: 60%;">PL000021</td> <td style="width: 20%; text-align: right;">¥16.50</td> <td style="width: 20%; border-left: 1px solid black;">Total amount</td> </tr> <tr> <td>CASH</td> <td style="text-align: right;">¥16.50</td> <td></td> </tr> </table> </div>	PL000021	¥16.50	Total amount	CASH	¥16.50	
PL000021	¥16.50	Total amount					
CASH	¥16.50						

Note If a discount entry is made for a link PLU/EAN link, the discount amount is calculated based on the total sales amount. The discount itself is given to the leading link PLU/EAN.

■ EAN learning function

When you enter or scan an undefined code, you are required to enter its unit price and the associated department. The code, associated department and unit price entered are stored in the EAN file and used for future EAN sales entries.

- Note**
- When there is no capacity remained in the file, the data is not stored in the file.
 - For the text for the EAN code, the text of its associated department is applied.
 - You can use the EAN learning function in the training mode. This may be convenient to practice the scanning system.

Procedure

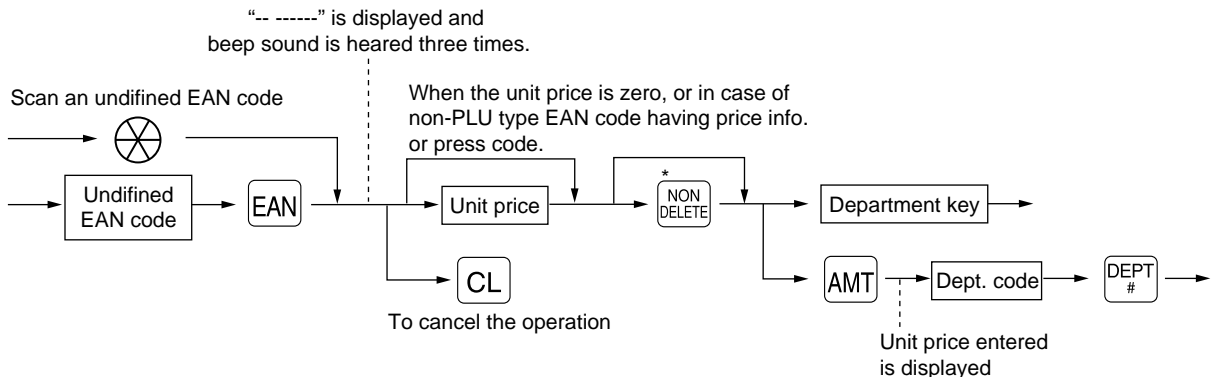

* Press the NON DELETE key when you want to exempt the EAN code entered from the non-accessed EAN delete function (deletion by executing #105 in Z1 mode).

Note For the repeat entry, use the REPEAT key.

Example

Key operation	Print									
5056789123404 EAN “-- -----” is displayed. → 750 5 TL	<div style="border: 1px solid black; padding: 5px;"> <table style="width: 100%; border-collapse: collapse;"> <tr> <td style="width: 60%;">5056789123404#</td> <td style="width: 20%;"></td> <td style="width: 20%;"></td> </tr> <tr> <td>DPT.05</td> <td style="text-align: right;">¥7.50</td> <td></td> </tr> <tr> <td>CASH</td> <td style="text-align: right;">¥7.50</td> <td></td> </tr> </table> </div>	5056789123404#			DPT.05	¥7.50		CASH	¥7.50	
5056789123404#										
DPT.05	¥7.50									
CASH	¥7.50									

■ Price inquiry (view) function (for EANs)

You can use this function when you want to know the unit price of the EAN item during transaction in the REG/MGR mode.

Procedure

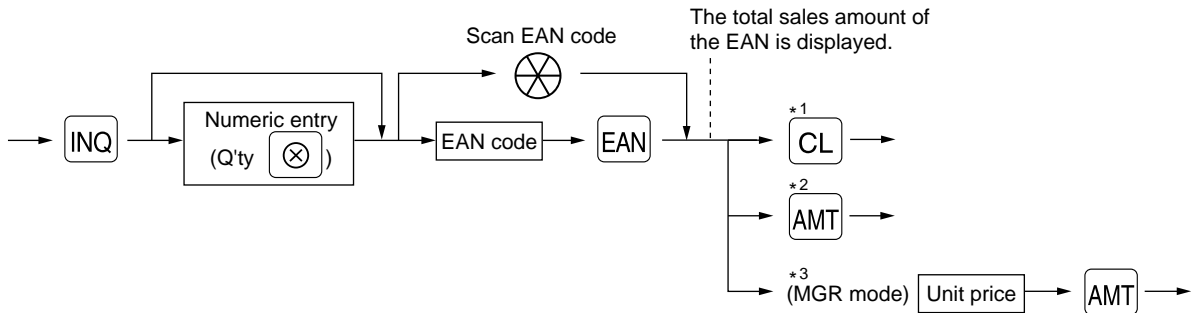

*1: Press the **CL** key to cancel the the inquiring (view) mode.

*2: Press the **AMT** key when you want to register the unit price of the EAN displayed.

*3: You can change the unit price temporarily at MGR mode. The unit price which is programmed in PGM mode is not changed (Price override entry).

Note For the repeat entry, use the **REPEAT** key.

Example

	Key operation	Print
	5 PLU/SUB	
"----" is displayed. →	INQ	PL000005 ¥2.00
Price is displayed. →	5089123456708 EAN	5089123456708#
	AMT	GRAPE ¥5.20
	TL	CASH ¥7.20

■ Price change function (for EANs)

Note To use this function, consult your dealer.

You can use this function when you need to change the unit price or associated department of an EAN item in REG/MGR mode.

There are two method for change:

1. Price change mode

You can change the preset price and/or the associated department of an EAN code without entering PGM mode.

2. Changing price during a transaction

When you has found a wrong EAN price and/or associated department upon transaction, you can correct them at the time of transaction. With the entry of new price and/or associated department, the preset price and/or associated department is automatically changed to the new price and/or associated department.

Note For the Non-PLU type EAN codes having price info. and press codes, the prices in the codes has the priority over the preset prices. So, for these codes, a changed price is valid only when price change is executed.

Procedure

Price change mode

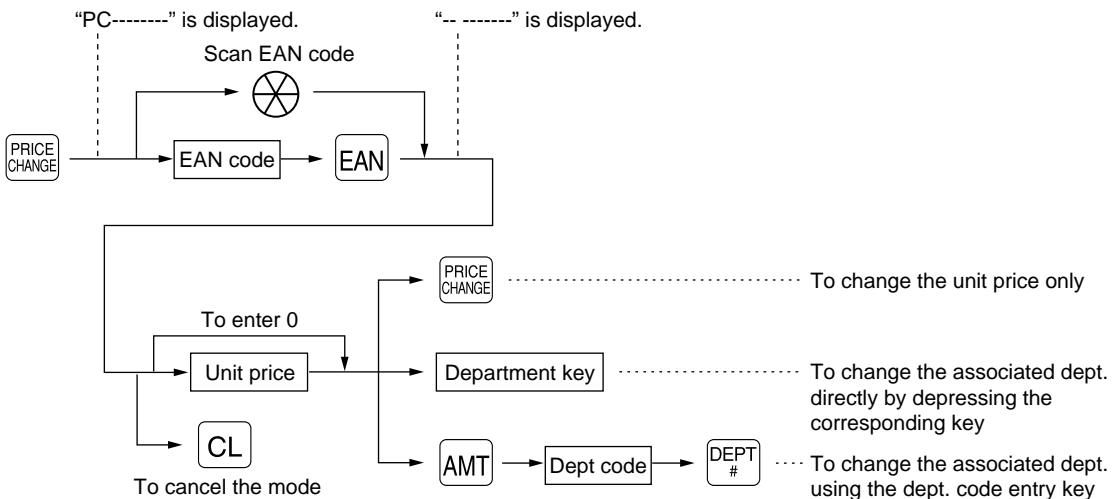

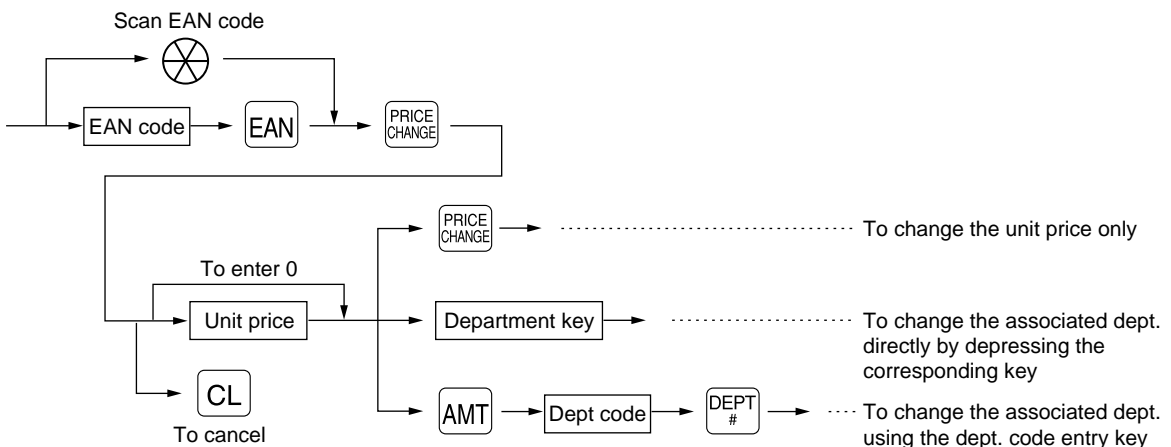

Changing price during a transaction



Example

• Price change mode

Key operation

5087654321106   





Print

```

    *PR.CHNG *
DEPT02
5087654321106#
ORANGE           *6.00
  
```

• Changing a price during a transaction

Key operation

5087654321106   600  

The journal printer prints the following format in this position.

```

    *PR.CHNG *
DEPT02
  
```



Associated dept. no.

Print

```

5087654321106#
ORANGE           *5.30
5087654321106#
ORANGE           *5.30
5087654321106#
ORANGE           *6.00
CASH             *6.00
  
```

Note

- When an undefined code is entered in the price change mode, the register goes to an error status.
- When you press the  key during a transaction, the EAN entry is voided of the 1st depression of the  key, then you are allowed to enter a correct price and/or associated department.
- When an associated department is changed, the item label for the department will be also changed automatically to the item label of new associated department.
- For the repeat entry, use the  key.

2 Displaying subtotals

Your machine provides the following two types of subtotals:

■ Normal subtotal

This is a subtotal which is displayed by pressing the **ST** key. When you press it, the subtotal of all entries which have been made is displayed and the symbol "□" will light up in the display.

Example

Key operation

100 **9**
100 **2**
700 **3**
ST
TL

Print

DPT.09	¥1.00
DPT.02	¥1.00
DPT.03	¥7.00
CASH	¥9.00

Note

Subtotal will not be printed on a receipt on the current factory setting. If you want to print it, consult your dealer.

■ Difference subtotal (Differ ST)

This is a subtotal which is printed by pressing the **DIFFER ST** key. You can get two or more difference subtotals in one transaction.

When you press it first, the difference subtotal of all entries which have been made is displayed and printed. If you press it second, you will get the difference subtotal of entries which have been made after you last got it.

Taxes are calculated each time you press the **DIFFER ST** key, and taxes and taxable subtotals are printed on the receipt according to the programming (job #2616).

Example

Key operation

100 **9**
200 **2**
DIFFER ST
700 **3**
TL

Print

DPT.09	¥1.00
DPT.02	¥2.00
DIFF ST	¥3.00
DPT.03	¥7.00
DIFF ST	¥7.00
CASH	¥10.00

3 Finalization of transaction

■ Cash or cheque tendering

Press the **[ST]** key to get a subtotal, enter the amount tendered by your customer, then press the **[TL]** or **[CA2]** key if it is a cash tender or press one of the **[CH1]** through **[CH4]** key if it is a cheque tender. When the amount tendered is greater than the amount of the sale, your register will show the change due amount and the symbol "⌈" will light up. Otherwise your register will show a deficit and the symbol "⌋" will light up. Make a correct tender entry.

Example

Cash tendering

Key operation

}
[ST]
 1000 **[TL]**

Print

```

  XXXTOTAL   ¥7.35
  CASH       ¥10.00
  CHANGE     ¥2.65
  
```

Cheque tendering

Key operation

}
[ST]
 1000 **[CH1]**

Print

```

  XXXTOTAL   ¥7.35
  CHECK      ¥10.00
  CHANGE     ¥2.65
  
```

■ Mixed tendering (cheque + cash)

Example

Key operation

}
[ST]
 1000 **[CH1]**
 500 **[TL]**

Print

```

  XXXTOTAL   ¥14.56
  CHECK      ¥10.00
  CASH       ¥5.00
  CHANGE     ¥0.44
  
```

■ Cash or cheque sale that does not need any tender entry

Enter items and press the **[TL]** or **[CA2]** key if it is a cash sale or press one of the **[CH1]** through **[CH4]** if it is a cheque sale. Your register will display the total sale amount.

Example

Key operation

300 **[6]**
 10 **[PLU/SUB]**
[TL]

Print

```

  DPT.06     ¥3.00
  PLO00010   ¥7.15
  CASH       ¥10.15
  
```

In the case of cheque sale

```

  CHECK      ¥10.15
  
```

■ Credit sale

Enter items and press the corresponding credit keys (CR1 through CR4).

Example	Key operation	Print
	2500 <input type="button" value="6"/>	DPT.06 ¥25.00
	3250 <input type="button" value="7"/>	DPT.07 ¥32.50
	<input type="button" value="CR1"/>	CREDIT1 ¥57.50

Amount tendering operations (i.e., change calculations) can be achieved by the through key when a PGM2 programming allows them.

■ Mixed-tender sale (cash or cheque tendering + credit tendering)

Example	Key operation	Print
	}	
	<input type="button" value="ST"/>	XXXTOTAL ¥49.50
	950 <input type="button" value="TL"/>	CASH ¥9.50
	<input type="button" value="CR2"/>	CREDIT2 ¥40.00

Note Press one of the through keys or the through keys in place of the key when your customer makes payment in cheques or by credit account.

4 Computation of VAT (Value Added Tax)/tax

■ VAT/ tax system

The machine may be programmed for the following six tax systems by your dealer.

Automatic VAT 1-6 system (Automatic operation method using programmed percentages)

This system, at settlement, calculates VAT for taxable 1 through 6 subtotals by using the corresponding programmed percentages.

Automatic tax 1-6 system (Automatic operation method using programmed percentages)

This system, at settlement, calculates taxes for taxable 1 through 6 subtotals by using the corresponding programmed percentages, and also adds the the calculated taxes to those subtotals, respectively.

Manual VAT 1-6 system (Manual entry method using programmed percentages)

Procedure



This system provides the VAT calculation for taxable 1 through 6 subtotals. This calculation is performed using the corresponding programmed percentages when the key is pressed just after the key.

Manual VAT 1 system (Manual entry method for subtotals that uses VAT 1 preset percentages)

Procedure

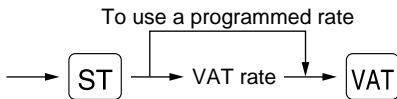

This system enables the VAT calculation for the then subtotal. This calculation is performed using the VAT 1 preset percentages when the **VAT** key is pressed just after the **ST** key. For this system, the keyed-in tax rate can be used.

Manual tax 1-6 system (Manual entry method using preset percentages)

Procedure

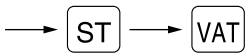

This system provides the tax calculation for taxable 1 through 6 subtotals. This calculation is performed using the corresponding programmed percentages when the **VAT** key is pressed just after the **ST** key. After this calculation, you must finalize the transaction.

Automatic VAT 1-3 and automatic tax 4-6 system

This system enables the calculation in the combination with automatic VAT 1 through 3 and automatic tax 4 through 6. The combination can be any of VAT1 through VAT3 corresponding to taxable 1 through taxable 3 and any of tax 4 through 6 corresponding to taxable 4 through taxable 6 for each item. The tax amount is calculated automatically with the percentages previously programmed for these taxes.

Note

- A PLU/EAN not programmed for any of the tax statuses is registered depending on the tax status of the department which the PLU/EAN belongs to.
- VAT/tax assignment can be printed at the fixed right position near the amount on the receipt as follows:

VAT1/tax1 —————> A
 VAT2/tax2 —————> B
 VAT3/tax3 —————> C
 VAT4/tax4 —————> D
 VAT5/tax5 —————> E
 VAT6/tax6 —————> F

When the multiple VAT/tax is assigned to a department, a PLU or an EAN, a smaller number of the VAT/tax will be printed. For details, contact your authorized SHARP dealer.

Example

Key operation

(When the manual VAT 1-6 system is selected) 550 **4**
ST
VAT
TL

Print

DPT.04	X5.50 A
SUBTOTAL	X5.50
TAX1 ST	X5.50
VAT 1	X0.21
NET 1	X5.29
CASH	X5.50

■ VAT shift entries

This feature is intended to shift the tax status of a particular department (PLU or EAN) programmed for taxable 1 or taxable 1 and taxable 3.

1. When the VAT shift entry is made for a particular department, PLU or EAN programmed for taxable 1, their tax status shifts to taxable 2.
2. When this entry is made for a particular department (PLU or EAN) programmed for taxable 1 and taxable 3, the tax status "taxable 1" remains unchanged, but the other "taxable 3" is ignored.

Procedure

Press the  to activate the VAT shift prior to entering department(s), PLU(s) or EAN(s) concerned.

Example

Key operation

(When the manual
VAT 1-6 system
is selected.)

550



Print

DPT.04	¥5.50 B
SUBTOTAL	¥5.50
TAX2 ST	¥5.50
VAT 2	¥0.21
NET 2	¥5.29
CASH	¥5.50

5 Auxiliary entries

■ Percent calculations (premium or discount)

- Your register provides the percent calculation for the subtotal or each item entry depending on the programming.
- Percentage: 0.01 to 99.99%

Percent calculation for the subtotal

Example

Key operation

(When a discount
of 10% is
programmed for
the  key)

4

140

225



Print

4x 1.40	
DPT.05	¥5.60
DPT.07	¥2.25
DPT.07	¥2.25
SUBTOTAL	¥10.10
	-10.00%
¥1	-1.01
CASH	¥9.09

Percent calculation for item entries

Example

Key operation	
(When a premium of 15% is programmed for the [%2] key)	
800	[6]
	[%2]
90	[PLU/SUB]
7	[.]
5	[%2]
	[TL]

Print

DPT.06	¥8.00
	15.00%
%2	¥1.20
PL000090	¥5.00
	7.5%
%2	¥0.38
CASH	¥14.58

■ Deduction entries

Your register allows you to deduct a certain amount less than a programmed upper limit after the entry of an item or the computation of subtotal depending on the programming.

Deduction for the subtotal

Example

Key operation	
575	[6]
80	[PLU/SUB]
	[ST]
100	[⊖2]
	[TL]

Print

DPT.06	¥5.75
PL000080	¥7.50
(-)>2	-1.00
CASH	¥12.25

Deduction for item entries

Example

Key operation	
675	[7]
75	[⊖]
	[TL]

Print

DPT.07	¥6.75
(-)>1	-0.75
CASH	¥6.00

■ Refund entries

For a refund entry, press the [RF] key just before you press a department key, [DEPT #] key, direct PLU key, [PLU/SUB] key or [EAN] key to finalize a transaction. The operation before pressing the [RF] key is the same as the one of normal operation. For example, if a refund item is the one entered into a department, enter the amount of the refund, then press the [RF] key and the corresponding department key in this order; if an item entered into a PLU is returned, enter the corresponding PLU code, then press the [RF] and [PLU/SUB] keys, and if a refund item is the one entered into an EAN, press the [RF] key, scan the EAN code and press the [EAN] key.

Example

Key operation	Print
250 RF 6 300 AMT 5 RF DEPT # 7 ⊗ 13 RF PLU/SUB 5089123456708 RF EAN TL	DPT.06 R-2.50 DPT.05 R-3.00 -7x 2.10 PL000013 R-14.70 5089123456708# GRAPE R-5.20 CHANGE ¥25.40

■ Printing of non-add code numbers

Enter a non-add code number such as a customer's code number and credit card number within a maximum of 16 digits and press the # key at any point during the entry of a sale. Your register will print it at once.

Example

Key operation	Print
1230 # 1500 6 CR1	#0000000000001230 DPT.06 ¥15.00 CREDIT1 ¥15.00

6 Payment treatment

■ Currency exchange

Your register allows payment entries of foreign currency. Pressing one of the EX1 through EX4 key creates a subtotal in foreign currency. Cash alone can be handled after currency exchange.

Procedure

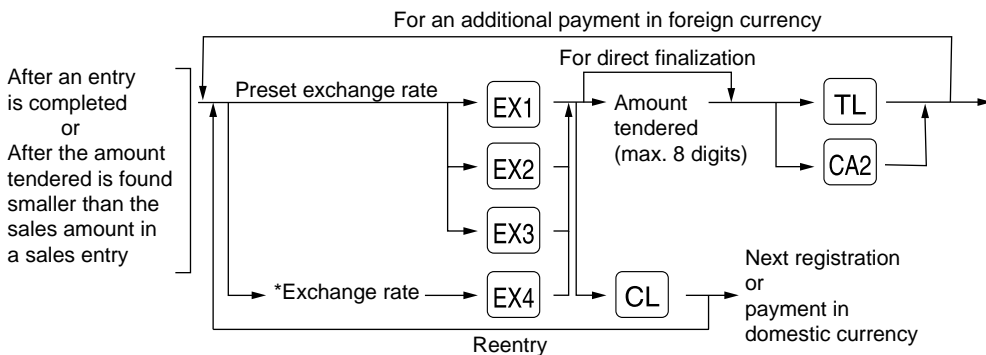

*Exchange rate: 0.000000 to 999.999999

Note When the amount tendered is short, the deficit is shown in domestic currency.

Example

Preset exchange rate (1.550220) - EX1

Key operation

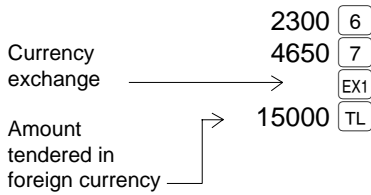

Print

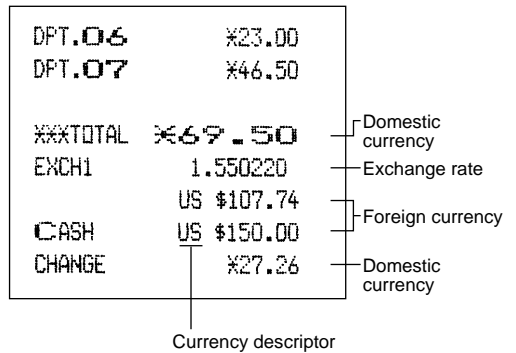

Manual exchange rate - EX4 (The [EX4] key can be used only for the manual entry of an exchange rate.)

Key operation

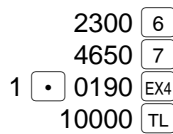

Print

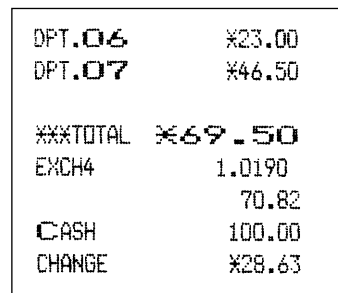

Received on account entries

Procedure

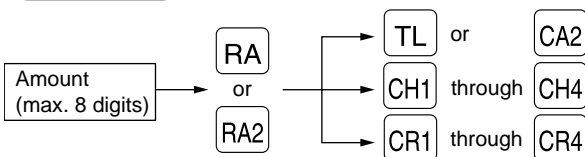

Example

Key operation



Print

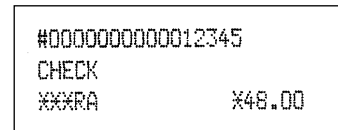

Paid out entries

Procedure

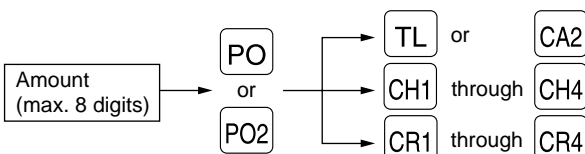

Example**Key operation**

6789
 3000

Print

```
#0000000000006789
CHECK
XXXPO           ¥30.00
```

■ No sale (exchange)

Simply press the key without any entry. The drawer will open and the printer will print "NO SALE" on both the journal and the receipt. If you let your machine print a non-add code number before pressing the key, a no sale entry is achieved with a non-add code number printed.

```
#00000000000045678
NO SALE
```

■ Cashing a cheque

Enter the cheque amount, then press one of the through key.

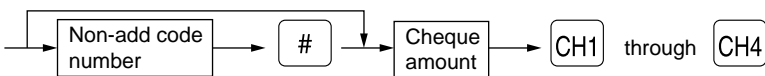
Procedure**Example****Key operation**

6789
 3000

Print

```
#0000000000006789
CA/CHK           ¥30.00
```

7 Automatic sequencing key (key) entries

You can achieve a programmed transaction simply by pressing a corresponding automatic sequencing key.

Example

= 500

Key operation

2

Print

```
DPT.07           ¥5.00
CASH             ¥5.00
```

CORRECTION

1 Correction of the last entry (direct void)

If you make an incorrect entry relating to a department, PLU/subdepartment, EAN, percentage (%1 through %4), deduction (⊖ through ⊖4) or refund, you can void this entry by pressing the ∞ key immediately after the incorrect entry.

Example

Key operation

```

1250 6
      ∞
2    PLU/SUB
      ∞
5012345678900 EAN
      ∞
600  8
      %2
      ∞
328  9
28   ⊖
      ∞
250  RF 6
      ∞
      TL
  
```

Print

```

DPT.06      ¥12.50
DPT.06      w-12.50
P000002     ¥1.50
P000002     w-1.50
5012345678900#
APPLE      ¥2.50
5012345678900#
APPLE      w-2.50
DPT.08      ¥6.00
              -15.00%
%2          -0.90
%2          w¥0.90
DPT.09      ¥3.28
<->1       -0.28
<->1       w¥0.28
DPT.06      R-2.50
DPT.06      Rw¥2.50

CASH      ¥9.28
  
```

2 Correction of the next-to-last or earlier entries (indirect void)

With the ∞ key, you can void any incorrect positive department, PLU/subdepartment or EAN entry made during a transaction if you find it before finalizing the transaction (e.g. pressing the $\overline{\text{TL}}$ key). This function is applicable to plus department, PLU/subdepartment and EAN entries only.

Example

Key operation

```

1310 6
1755 7
10  PLU/SUB
    8
58  PLU/SUB
   825 7
5012345678900 EAN
1310  6
    8
58  825  PLU/SUB
5012345678900  EAN
                TL
    
```

Print

```

DPT.06      ¥13.10
DPT.07      ¥17.55
PLO00010    ¥7.15
PLO00008    ¥3.00
PLO00058    ¥3.00
DPT.07      ¥8.25
5012345678900#
APPLE       ¥2.50
DPT.06      ¥-13.10
PLO00008    ¥-3.00
PLO00058    ¥-3.00
5012345678900#
APPLE       ¥-2.50

CASH       ¥32.95
    
```

3 Subtotal void

You can void an entire transaction. Once subtotal void is executed, the transaction is aborted and the register issues a receipt.

Example

Key operation

```

1310 2
1755 6
10  PLU/SUB
35  PLU/SUB
Subtotal void {
                ST
                8
                ST
    
```

Print

```

DPT.02      ¥13.10
DPT.06      ¥17.55
PLO00010    ¥7.15
PLO00035    ¥3.00
SUBTOTAL    ¥40.80
SETL  ¥     -40.80
***TOTAL    ¥0.00
    
```

4 Correction of incorrect entries not handled by the direct or indirect void function

Any errors found after the entry of a transaction has been completed or during an amount tendered entry cannot be voided. These errors must be corrected by the manager.

The following steps should be taken:

1. If you are making the amount tendered entry, finalize the transaction.
2. Make correct entries from the beginning.
3. Hand the incorrect receipt to your manager for its cancellation.

SPECIAL PRINTING FUNCTIONS

1 Copy receipt printing

If your customer wants a receipt after you have finalized a transaction with the receipt function being in the "OFF" status (no receipting), press the **RCPT** key. This will produce a receipt. Your register can also print a copy receipt when the receipt function is in the "ON" status.

Note Pressing the **RCPT** key in the OP X/Z mode before registration toggles the status "ON" and "OFF".

Example Printing a copy receipt after making the entries shown below with the receipt function being in the "OFF" status

Key operation	Print
850 2 3 ⊗ 150 1 TL	Print on the journal
	<pre> 31/08/01 14:32 11 123456 #1350 MAVER DPT.02 ¥8.50 3x 1.50 DPT.02 ¥4.50 CASH ¥13.00 11 </pre>
For receipting → RCPT	Print on the receipt
	<pre> 31/08/01 14:32 11 123456 #1350 MAVER DPT.02 ¥8.50 3x 1.50 DPT.02 ¥4.50 CASH ¥13.00 </pre>

When the receipt function is in the "ON" status and you press the **RCPT** key to make a second copy

<pre> 31/08/01 14:32 11 123456 #1350 MAVER *COPY* DPT.02 ¥8.50 3x 1.50 DPT.02 ¥4.50 CASH ¥13.00 </pre>	When the receipt function is in the "ON" status, the "*COPY*" symbol will be printed on the receipt.
---	--

2 Guest check copy

You can use this function when you want to take a copy of guest check.
Press the  key and make a desired entry.

Procedure

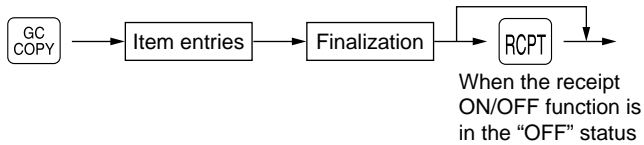

Note *The guest check copy has nothing to do with the memory.*

Example

Key operation

1480 



Print

```
      *G.C COPY*
DPT.02      ¥14.80
CASH      ¥14.80
```

3 Validation printing function

Your cash register can perform a validation printing.

Validation slip setting and printing

Insert a validation slip into the printer with its printed face to the front of the machine (see the figure below), then press the  key.

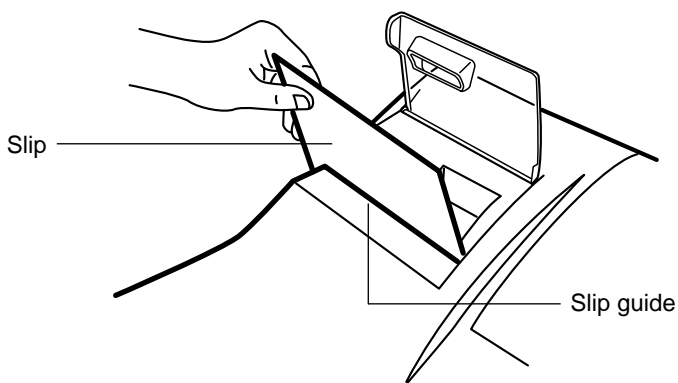

Note *To insure proper validation, insert the slip securely until it stops.*

■ Validation printing examples

Validation printing of item entries

Example

• Department entry

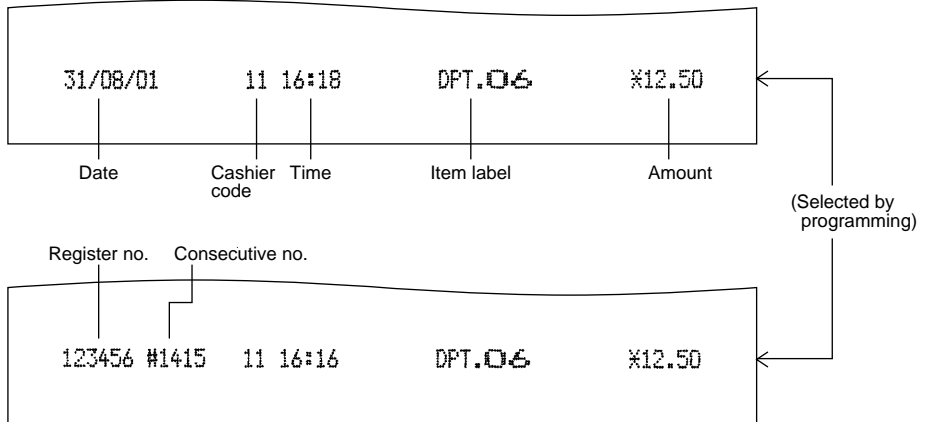

• PLU entry

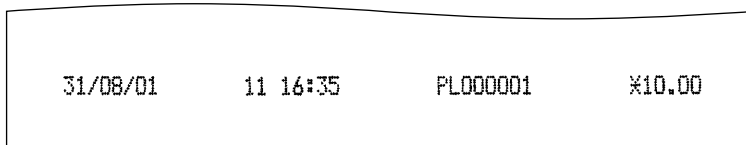

• EAN entry

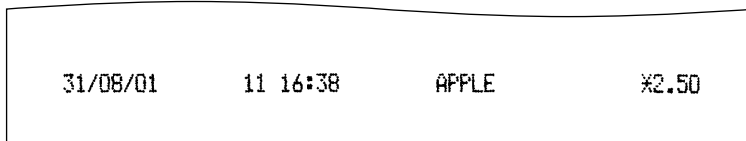

• Deduction entry (⊖ through ⊖ 4)

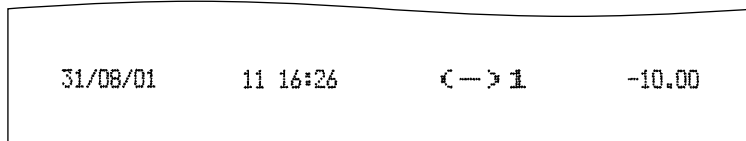

• Refund entry

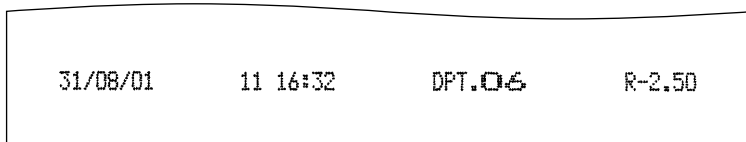

• Item percent entry (%1 through %4)

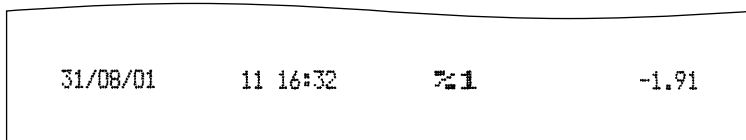

- Void entry

```

31/08/01      11 16:32      DFT.06      w-12.50
  
```

Validation printing after the finalization of a transaction

```

31/08/01      11 16:32      ***TOTAL      ¥33.19
  
```

Transaction symbol Amount

TL or **CA2** key

- When an amount tendered entry is made
- When no amount tendered entry is made

CH1 to **CH4** key

- When an amount tendered entry is made
- When no amount tendered entry is made
- When a check cashing operation is made

CR1 to **CR4** key

RA key

RA2 key

PO key

PO2 key

Transaction symbol

*** TOTAL

CASH or CASH2

CHECK or CHECK2 to CHECK4

CHECK or CHECK2 to CHECK4

CA/CHK

CREDIT1 to CREDIT4

*** RA

*** RA2

*** PO

*** PO2

Amount

Sales amount

Sales amount

Amount tendered

Sales amount

Amount tendered

Sales amount

Amount received on account

Amount received on account

Amount paid out

Amount paid out

Validation printing of the training mode

```

31/08/01      03 15:07      T  CASH      ¥17.00
  
```

Training mode symbol

Note

- When you make an entry for which compulsory validation printing has been programmed, the "⏏" will light up in the display. Carry out the validation printing successively until the "⏏" goes off (or by the programmed number of times) while replacing validation slips. You cannot proceed to any further entry unless this printing is completed.
- Programmed compulsory validation printing can be overridden by performing the following operation depending upon your initial program setup.

1. Turn the mode switch to the "MGR" position.

2. → VP

■ Validation slip specification

Make validation slips according to the following specification. The use of any slips other than specified causes the printer to malfunction.

- Type of paper: plain paper
- Paper thickness: 0.07 to 0.14 mm
- Paper width: 130 mm or more
- Paper height: 70 mm or more
- Print position

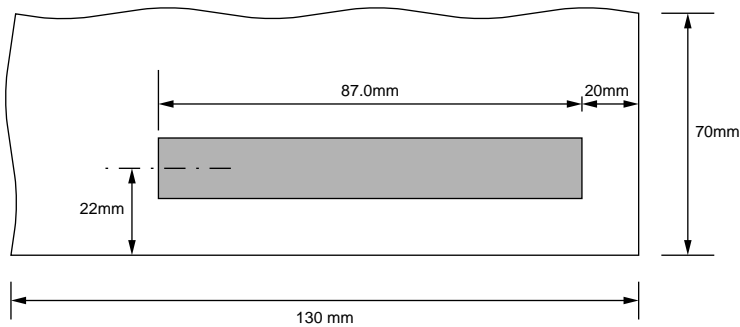

4 Printing of the employee arrival and departure times

The register allows the cashier to print the employee arrival and departure times, etc. using the validation printing function.

1. Turn the mode switch to the "OP X/Z" position.
2. Put a card into the paper chute and perform the following key operation.

- Arrival time
Numeric key 1 →
- Departure time
Numeric key 2 →

3. Sample printout

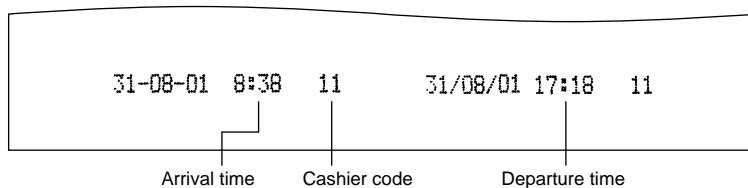

OVERLAPPED CASHIER ENTRY

This function allows you to switch from one cashier to another and to interrupt the first cashier's entry. So the second cashier can do his or her entry in this mode. For actual use of this function, consult your dealer.

Example

Cashier 1: Entry started

Cashier 2: Cashier change (1 to 2), interrupt initiated

Cashier 2: Transaction finished (2)

Cashier 1: Cashier change (2 to 1), entry restart

Note

- When the cashier and clerk system is applied for your register, you cannot operate the overlapped cashier entry.
- The overlapped cashier entry is not effective while the tendering sale is going on.
- If any cashier is still making an entry (or has not finalized the transaction yet), the machine does not run in any mode other than REG and MGR and can print no X/Z reports. The error code "E22" and the corresponding cashier code(s) are displayed at this time.

Key operation		Comments
1. Cashier 1 is assigned.	(1 <input type="text" value="CASH #"/> 100 <input type="text" value="1"/> 360 <input type="text" value="3"/> <input type="text" value="3"/>	The entry by cashier 1 is started.
2. Cashier 2 is assigned.	2 <input type="text" value="CASH #"/> 3 <input type="text" value="⊗"/> 150 <input type="text" value="2"/> <input type="text" value="TL"/>	The entry by cashier 2 is started. (The entry by cashier 1 is interrupted.)
3. Cashier 1 is assigned.	1 <input type="text" value="CASH #"/> 100 <input type="text" value="1"/> 360 <input type="text" value="3"/> <input type="text" value="TL"/>	The entry by cashier 1 is restarted. The transaction by cashier 1 is finalized.

OPERATOR MAINTENANCE

1 In case of power failure

When power is lost, the machine retains its memory contents and all information on sales entries.

- When power failure is encountered in register idle state or during an entry, the machine returned to the normal state of operation after power recovery.
- When power failure is encountered during a printing cycle, the register prints "======" and then carries out the correct printing procedure after power recovery. (See the sample print.)

```
31/08/01 19:16      11
123456 #1577  MAVER
12 BETH

DPT.07           ¥10.00
DPT.01=====
DPT.08           ¥35.00

CASH            ¥45.00
```

2 In case of printer's motor locking

If the printer's motor happens to lock, the printing stalls, the register will continuously start an intermittent beeping tone. If this occurs, please follow the procedure below.

1. Unplug the power cord from the outlet.
2. Insure the printer is clear of any obstructions (e.g paper jams, etc).
3. Plug the power cord into the outlet. The following format appears in the display.
" _ _ _ _ _ _ _ _ _ _ "
4. Feed the receipt and journal paper to the proper position.
5. Press the **[CL]** key.
6. The register prints the power failure symbol and continues printing.

3 Paper roll near-end sensing function (only for the journal paper) <option>

When the journal paper roll comes near the end or is not loaded, the machine senses this condition and sounds an alarm, displaying the error code "E04". At this time, clear the alarm with the **[CL]** key and replace the paper roll as soon as possible. The following entry can be made after clearing the alarm. However, since this function works each time one transaction is completed, the alarm sound will be emitted again as the following transaction is completed unless the paper roll is replaced.

- The sensing position depends upon the size of the paper tube. Therefore, it is advisable to use paper rolls - whose paper tube is 18 mm in O.D. and 12 mm in I.D. - specified by SHARP.
- If the sensing occurs too early or late, contact your dealer.

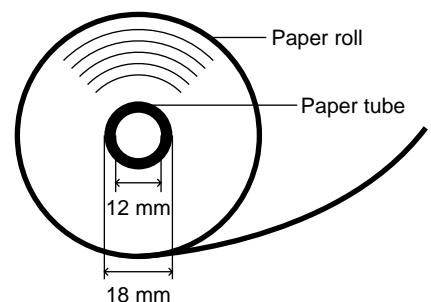

4 Installing and removing the paper roll

■ Recording paper specifications

Be sure to use paper rolls specified by SHARP.

The use of any other paper rolls than specified could cause paper jamming, resulting in register malfunction.

Paper specification

Paper width:	44.5 ± 0.5 mm
Max. outside diameter:	80 mm
Weight:	52.3 — 64.0 g/m ²
Quality:	bond paper
Paper tube:	18 mm

- Be sure to set paper roll(s) prior to using your machine, otherwise it may cause a malfunction.

Install the paper roll in the printer. Be careful then to set the roll and cut the paper end correctly.

(How to set the paper roll)

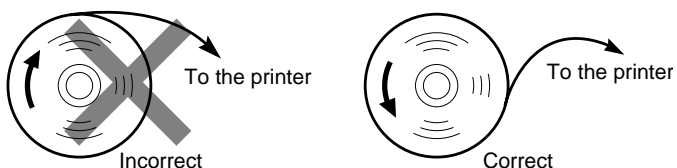

(How to cut the paper end)

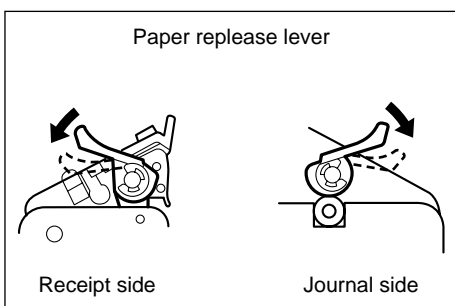
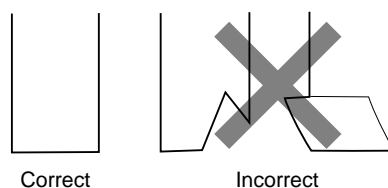

To release the paper, press the paper release lever down. It is also used for removing a paper jam. The method for removing a paper jam is described in "Removing a paper jam" later in this section.

■ Installing the paper roll

Installing the receipt paper roll

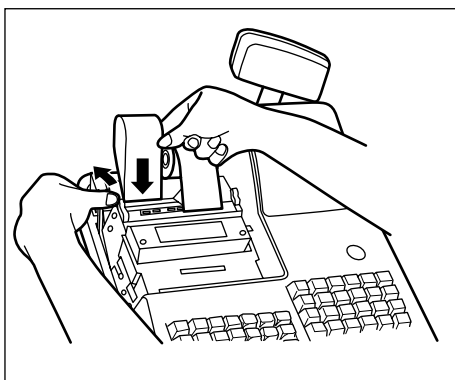

1. Turn the mode switch to the "REG" position with the AC cord connected.
2. Remove the printer cover.
3. Set the paper roll correctly and drop it into the printer.
4. Press the receipt paper release lever down and insert the paper end into the paper chute of the printer.
5. Pull the paper end that has come out of the printer, holding down the lever.
6. Advance the paper by a required length by pressing the receipt paper feed key.
7. Replace the printer cover.

Installing the journal paper roll

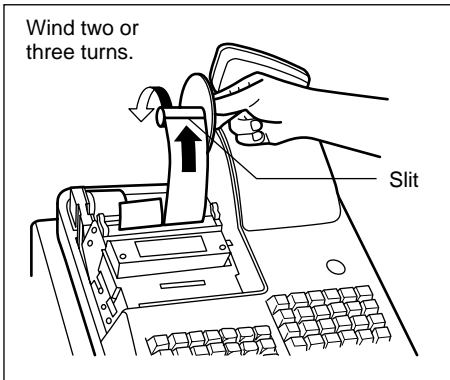

1. Turn the mode switch to the "REG" position with the AC cord connected.
2. Remove the printer cover.
3. Set the paper roll correctly and drop it into the printer.
4. Press the journal paper release lever down, insert the paper end that has come out of the printer into the slit in the paper take-up spool, wind it two or three turns around spool shaft.
5. Set the spool on the bearing.
6. Replace the printer cover.

Note

Make sure the ink ribbon cassette has been mounted on the printer when installing the receipt paper roll or the journal paper roll.

Removing the paper roll

When a red dye appears on the paper roll, it is time to replace the existing paper roll. Replace the paper roll with a new one.

Removing the receipt paper roll

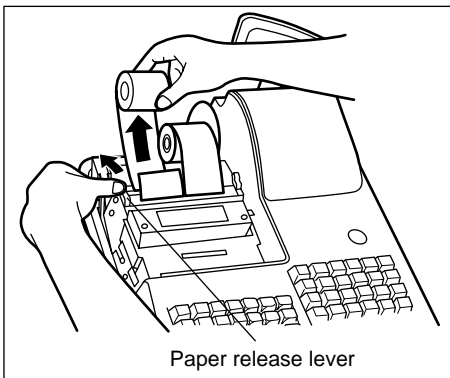

1. Remove the printer cover.
2. Press and hold the receipt paper release lever down and remove the existing paper roll from the paper roll location.

Note

Be sure to pull the roll in the direction of the arrow.

Removing the journal paper roll

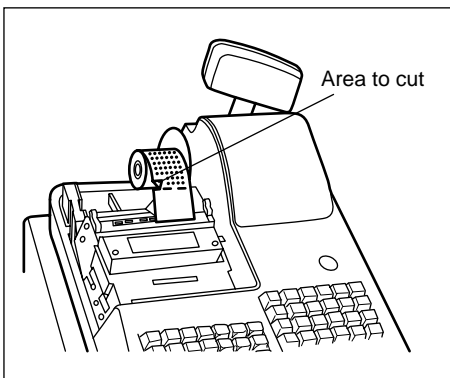

1. Remove the printer cover.
2. Press the journal paper feed key to advance the paper by several lines and then cut it.

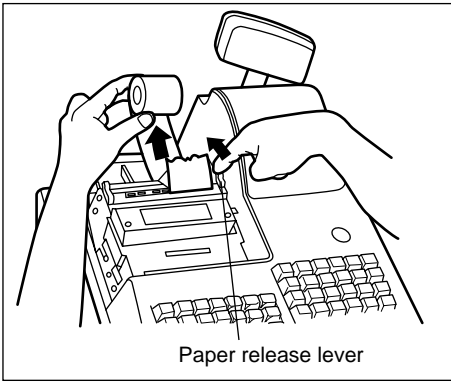

3. Press and hold the journal paper release lever down and remove the existing paper roll from the paper roll location.

Note

Be sure to pull the roll in the direction of the arrow.

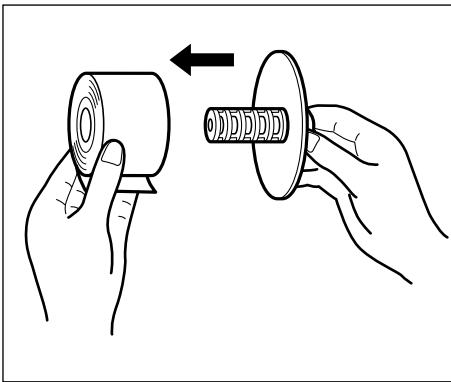

4. Remove the paper roll from the take-up spool.

■ Removing a paper jam

1. Remove the printer cover.
2. Pressing the receipt and journal paper release levers at the same time, lift part (A) up. (See the drawing below.)
3. Remove the paper jam.
4. Replace part (A) gently.
5. Reset the paper roll correctly following the steps shown in "Installing the paper roll".
6. Replace the printer cover.

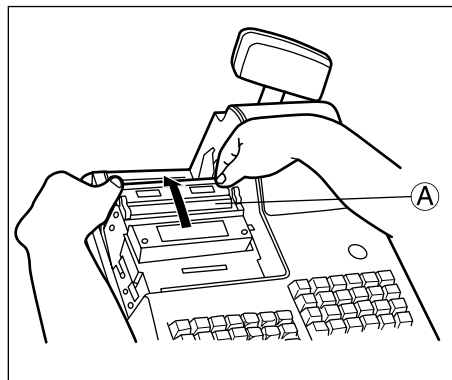
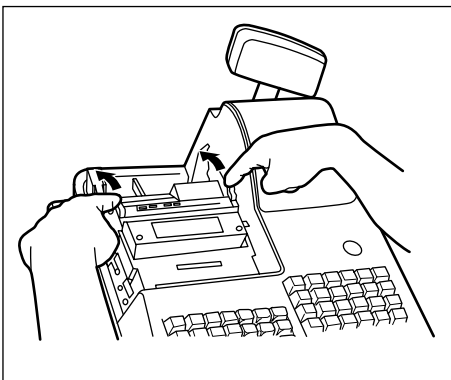

5 Installing the ink ribbon cassette

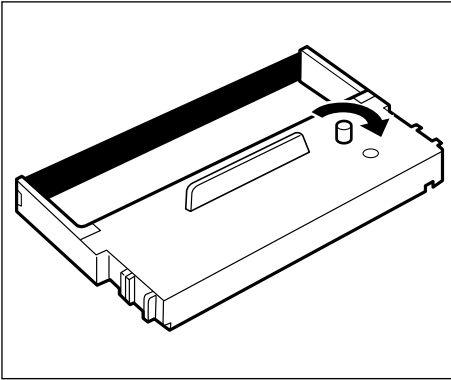

1. Remove the printer cover.
2. Rotate the knob on the ink ribbon cassette in the direction of the arrow to stretch the ribbon tight.

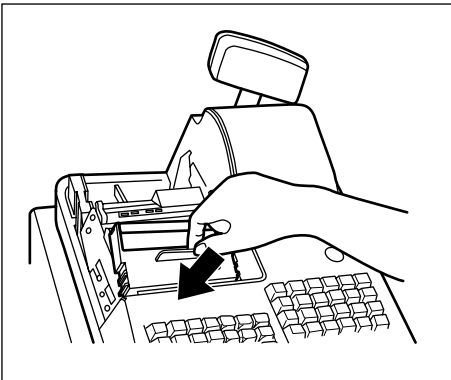

3. Put the ink ribbon cassette in the location indicated in the figure at left and fix it by using the right and left guides.
4. Rotate the knob two or three turns in the direction of the arrow to make sure it rotates smoothly. Also, make sure the ribbon is not folded.

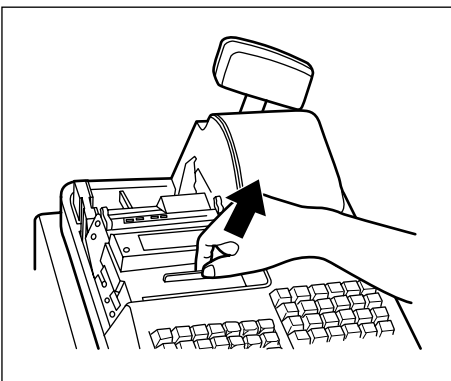

5. To remove the cassette, lift it up.

Precautions:

- Be sure to use an ink ribbon cassette specified by SHARP. The use of any ink ribbon cassettes other than specified could cause troubles in the printer.
- After opening the parcel, be careful not to make the surface of the ink ribbon dirty, and install it soon.
- If you preserve the ink ribbon cassette for a long time, the ink will be dry and the ink ribbon cassette's life will be shortened. Please use it soon. If you do not use it soon, put it in an airtight receptacle and preserve it in a cool and dark place.

6 Removing the till and the drawer

The till in the register is detachable. After closing your business for the day, remove the till from the drawer and keep the drawer open. The coin case is also detachable from the till. To detach the drawer, pull it forward fully with the till removed, and remove it by lifting it up.

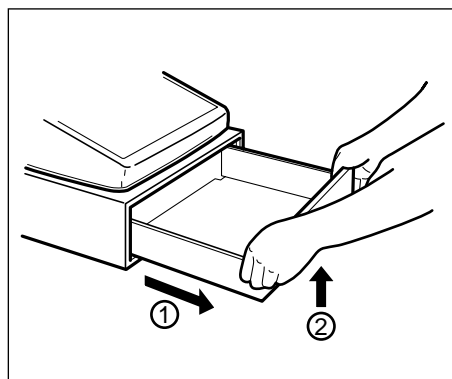
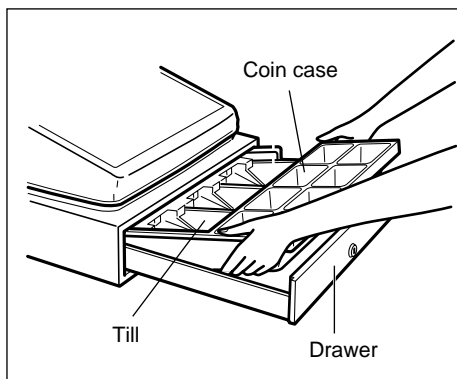

7 Opening the drawer by hand

The drawer automatically opens in the usual way. However, when power failure is encountered or the machine becomes out of order, slide the lever located on the machine bottom toward the rear. (See the figure below.) The drawer will not open, if it is locked with a drawer lock key.

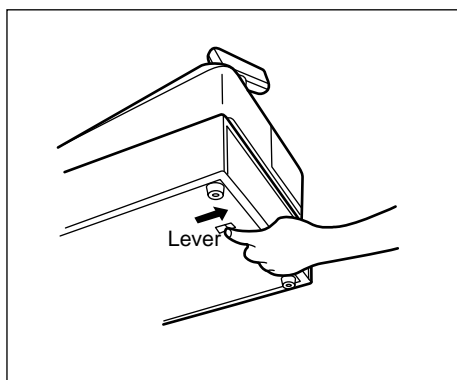

8 Installing the fixing angle bracket

To prevent the register from moving when the drawer opens, the fixing angle bracket is supplied with the register. By attaching the bracket to the table where the register is installed, you can hook the register on this bracket and secure the register to its position.

How to install the fixing angle bracket

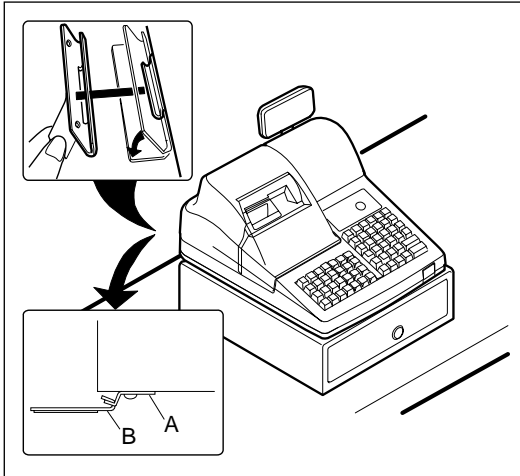

1. Thoroughly clean the location where the fixing angle bracket (B) is to be placed.
2. Peel off the adhesive tape on the fixing angle bracket.
3. Hook the angle bracket onto the hook (A) that is located at the bottom rear of the register.
4. Firmly stick the fixing angle bracket to the table surface that you cleaned above.

How to remove the register from the fixing angle bracket

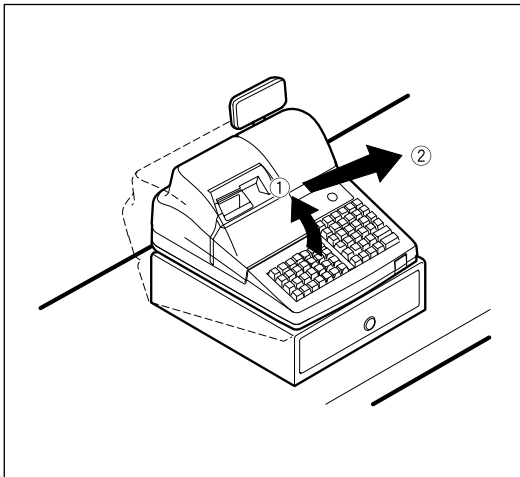

1. Lift up the front of the register and pull the register towards you.

9 Before calling for service

The malfunctions shown in the left-hand column below, labeled "Fault," do not necessarily indicate functional faults of the machine. It is therefore advisable to refer to the "Checking" shown in the right-hand column before calling for service.

Fault	Checking
(1) The display won't be illuminated even when the mode switch is turned to any other position than "ϕ".	<ul style="list-style-type: none"> • Is power supplied to the electric outlet? • Is the power cord plug out or loosely connected to the electrical outlet?
(2) The display is illuminated, but the whole machine refuses registrations.	<ul style="list-style-type: none"> • Is a cashier code assigned to the register? • Is a clerk code assigned to the register? • Is the mode switch set properly at the "REG" position?
(3) No receipt is issued.	<ul style="list-style-type: none"> • Is the receipt paper roll properly installed? • Is there a paper jam? • Is the receipt function in the "OFF" status?
(4) No journal paper is taken up.	<ul style="list-style-type: none"> • Is the take-up spool installed on the bearing properly? • Is there a paper jam?
(5) Printing is unusual.	<ul style="list-style-type: none"> • Is the ink ribbon cassette installed properly? • Is the ink ribbon life completed?

■ Error code table

When the following error codes are displayed, press the **CL** key and take a proper action according to the table below.

Error code	Error status	Action
E01	Registration error	Make a correct key entry.
E02	Misoperation error	Make a correct key entry.
E03	Undefined code is entered.	Enter a correct code, or declare it by the programming.
E04	Journal paper is nearly empty.	Replace a journal paper roll with a new one.
E05	Secret code error	Enter a correct secret code.
E07	Memory is full.	Expand the file within a capacity of memory.
E11	Compulsory depression of the ST key for direct finalization	Press the ST key and continue the operation.
E12	Compulsory tendering	Make a tendering operation.
E22	Overlapped cashier error	
E23	Cashier resetting over error	
E31	Compulsory non-add code entry	Enter a non-add code.
E32	No entry of your cashier code	Make a cashier code entry.
E33	The current cashier code should not be changed.	Change a cashier after finalizing the transaction.
E34	Overflow limitation error	Make a registration within a limit of entry.
E35	The open price entry is inhibited.	Make a preset price entry.
E36	The preset price entry is inhibited.	Make an open price entry.
E37	The direct finalization is inhibited.	Make a tendering operation.
E39	Power-off during validation printing	Print a validation again.
E58	Undefined clerk code is entered	Enter a correct clerk code
E67	Registration buffer is full.	
E76	The drawer is still opened.	Close the drawer.

LIST OF OPTIONS

For your register, the following options are available.
For details, contact your dealer.

- RAM memory chip model ER-03RA
- Remote drawer model ER-05DW
- Till model ER-58CC and till cover model ER-03CV
- Key kit models

By using the following key kits, you can change the keyboard layout of your register including the expansion of the number of departments.

ER-11KT7: 30 regular size key kits

ER-12KT7: 30 1 x 2 size key kits

ER-22KT7: 10 2 x 2 size key kits

ER-11DK7G: 30 regular size dummy key kits

ER-51DK7G: 10 5 x 1 size dummy key kits

- Hand scanner model ER-A6HS1

FOR CUSTOMERS IN U.K.

IMPORTANT

The wires in this mains lead are coloured in accordance with the following code:

BLUE:	Neutral
BROWN:	Live

As the colours of the wires in the mains lead of this apparatus may not correspond with the coloured markings identifying the terminals in your plug proceed as follows.

The wire which is coloured **BLUE** must be connected to the terminal which is marked with the letter **N** or coloured black.

The wire which is coloured **BROWN** must be connected to the terminal which is marked with the letter **L** or coloured red.

The apparatus must be protected by a 3A fuse in the mains plug or distribution board.

CAUTION: DO NOT CONNECT THE LIVE (BROWN) WIRE OR THE NEUTRAL (BLUE) WIRE TO THE EARTH TERMINAL OF YOUR 3-PIN MAINS PLUG.

Environment Protection

The device is supported by a battery. To dispose the battery safely to protect the environment, please note the following points:

- Take the used battery to your local waste depot, dealer or customer service centre for recycling.
- Do not throw the used battery into fire, into water or into the household waste!

Umweltschutz

Das Gerät wird durch eine Batterie gestützt. Um die Batterie sicher und umweltschonend zu entsorgen, beachten Sie bitte folgende Punkte:

- Bringen Sie die leere Batterie zu Ihrer örtlichen Mülldeponie, zum Händler oder zum Kundenservice-Zentrum zur Entsorgung.
- Werfen Sie die leere Batterie niemals ins Feuer, ins Wasser oder in den Hausmüll.

Protection de l'environnement

L'appareil est supporté sur pile. Afin de protéger l'environnement, nous vous recommandons de traiter la pile usagée la façon suivante:

- Apporter la pile usagée à votre centre de traitement des ordures ménagères le plus proche ou, à votre revendeur ou, au service après-vente, pour recyclement.
- Ne jamais jeter la pile usagée dans une source de chaleur, dans l'eau ou dans les vide-ordures.

Miljöskydd

Denna produkt nöddrivs av batteri.

Vid batteribyte skall följande iakttagas:

- Det förbrukade batteriet skall inlämnas till er lokala handlare eller till kommunal miljöstation för återinsamling.
- Kasta ej batteriet i vattnet eller i hushållssoporna. Batteriet får ej heller utsättas för öppen eld.

SHARP®
SHARP CORPORATION

Free Manuals Download Website

<http://myh66.com>

<http://usermanuals.us>

<http://www.somanuals.com>

<http://www.4manuals.cc>

<http://www.manual-lib.com>

<http://www.404manual.com>

<http://www.luxmanual.com>

<http://aubethermostatmanual.com>

Golf course search by state

<http://golfingnear.com>

Email search by domain

<http://emailbydomain.com>

Auto manuals search

<http://auto.somanuals.com>

TV manuals search

<http://tv.somanuals.com>