

PYRAMID[®]

Gold Series

OWNER'S MANUAL



MODEL: 718EX

**7-BAND CONTROL
STEREO GRAPHIC EQUALIZER
PRE-AMPLIFIER**

FEATURES

- * 7-BAND GRAPHIC EQUALIZER CONTROL
- * FRONT/REAR FADER CONTROL
- * SUBWOOFER OUTPUT LEVEL CONTROL
- * CD INPUT JACK
- * LED OUTPUT LEVEL DISPLAY
- * POWER ON/OFF SWITCH
- * TONE DEFEAT SWITCH
- * HIGH IMPEDANCE INPUT/OUTPUT (RCA TYPE JACK)
- * SUBWOOFER FREQUENCY CROSSOVER SELECTOR

CONTROLS:

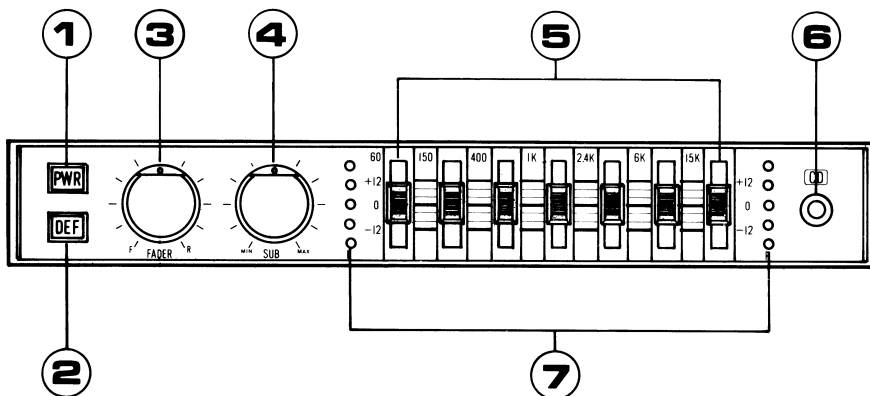

- | | |
|----------------------------|-------------------------|
| 1. POWER ON/OFF SWITCH | 5. EQUALIZER CONTROL |
| 2. TONE DEFEAT SWITCH | 6. CD INPUT JACK |
| 3. FADER CONTROL | 7. LED POWER INDICATORS |
| 4. SUBWOOFER LEVEL CONTROL | |

OPERATION

1. POWER SWITCH

Pressing the power switch in to activates the equalizer.

2. TONE DEFEAT SWITCH

When the tone defeat switch is pushed to the "ON" position the equalizer controls are not being employed and the amplifier operation is essentially flat. Depressing the tone defeat button again to "OFF" brings the equalizer into operation.

3. FADER CONTROL

A) DUAL AMPLIFIER 4-SPEAKER SYSTEM

Rotating the knob to the FRONT side brings up the level of the FRONT speakers.

Rotating to the REAR side brings up the level of the REAR speakers. At mid position, both sets of speakers are at maximum level.

B) 2-SPEAKER SYSTEM

The fader control knob should be turned to the end position which provides the loudest sound for using both sets of speakers.

4. SUBWOOFER LEVEL CONTROL

Allows adjustment of appropriate subwoofer sound level for a particular tape or broadcast source.

5. EQUALIZER CONTROL

The 718 has 7-bands of frequency control (60Hz, 150Hz, 400Hz, 1KHz, 2.4KHz, 6KHz, 15KHz) attenuated by individual sliders.

The center detent position represent 0dB boost. By sliding the slider up or down you can either increase (UP) or decrease (DOWN) the amount of boost by 12dB.

6. COMPACT DISC INPUT JACK (3.5mm)

Connect your portable CD player to the CD input JACK on the front panel by a stereo path cord with a stereo mini plug at both ends. Turn on your CD player and then turn on the equalizer.

7. LED POWER INDICATORS

These rows of LED'S show the PRE-AMPLIFIER output LEVEL independently both left and right channel, measure on peak level.

8. SUBWOOFER FREQUENCY CROSSOVER

The three position switch on the rear side of the unit adjusts the crossover point for your subwoofer system. The 718 features separate dual RCA outputs for the subwoofer channel so that the subwoofers can run on a separate amplifier or separate channels of a multi-channel amplifier.

The crossover switch is adjustable to either 80, 120 or 160Hz. Depending on your subwoofer frequency response adjust this switch to the proper setting.

INSTALLATION:

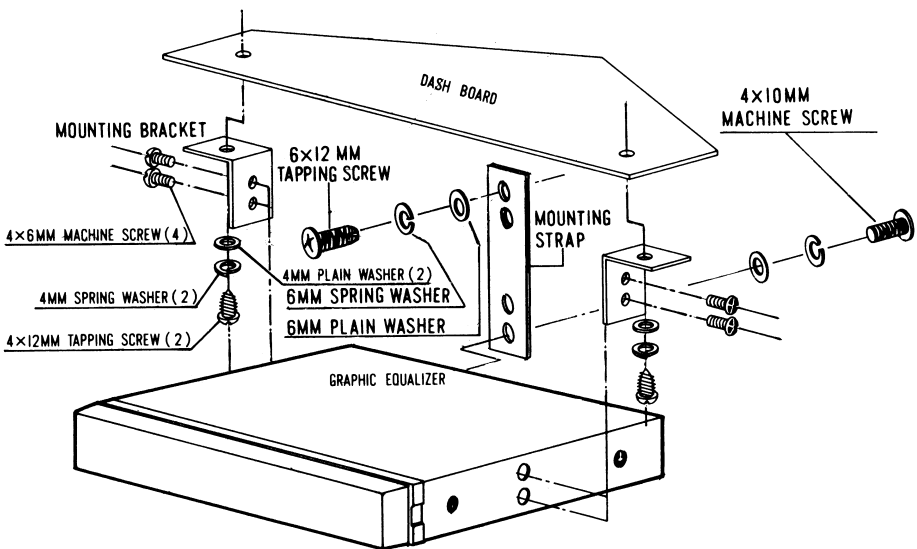

ELECTRICAL CONNECTIONS

There are two types of inputs that the 718 accepts.

1. Low Level High Impedance RCA Jacks.
2. High Level Low Impedance Speaker Line Inputs (not included).

If your radio has RCA Jack Outputs use these to input the signal into the 718 RCA inputs.

If your radio does not have RCA output jacks as in the case of most standard OEM radios you can use the speaker outputs from those head units to power the 718 by interfacing them with a High/Low level impedance adaptor like the Pyramid Model NS60 or any of the other numerous models available. Be sure to use the correct adaptor so that if you have a high power radio it will be able to reduce the level low enough not to cause any noise problem in the installation.

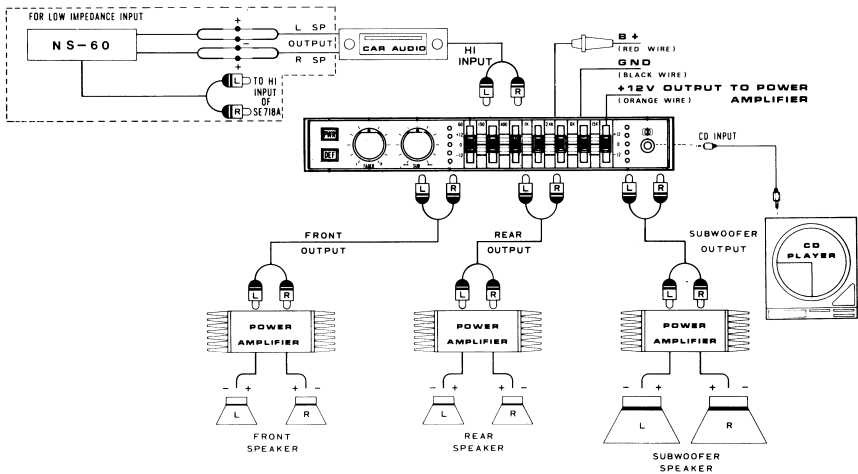

SPECIFICATIONS:

Input Impedance10K0hm
Control Frequencies.60, 150, 400, 1K, 2.4K, 6K, 15KHz
Control Range \pm 12dB boost or cut
Frequency crossover point80/120/160Hz
Frequency Response20-20KHz
Signal to NoiseBetter than 85dB (A-Wtd)
Input Sensitivity for 400mV Output200mV
Power Requirement11-16 volts negative GND
Subwoofer Crossover12dB Octave Slope 2nd Order Butterworth
DistortionLess than 0.05%

CARE AND MAINTENANCE

Your Pyramid Stereo 7-Band Graphic/Equalizer is an example of superior design and craftsmanship. The following suggestions will help you care for your equalizer/booster so you can enjoy it for years.



Keep the graphic/equalizer dry. If it does get wet, wipe it dry immediately. Liquids contain minerals that can corrode electronic circuits.



Use and store the graphic/equalizer only in normal temperature environments. Temperature extremes can shorten the life of electronic devices and distort or melt plastic parts.



Handle the graphic/equalizer gently and carefully. Dropping it can damage the circuit boards and can cause it to work improperly.



Keep the graphic/equalizer away from dust and dirt, which can cause premature wear of parts.



Wipe the graphic/equalizer with a damp cloth occasionally to keep it looking new. Do not use harsh chemicals, cleaning solvents, or strong detergents to clean the graphic/equalizer.

www.pyramidcaraudio.com

Free Manuals Download Website

<http://myh66.com>

<http://usermanuals.us>

<http://www.somanuals.com>

<http://www.4manuals.cc>

<http://www.manual-lib.com>

<http://www.404manual.com>

<http://www.luxmanual.com>

<http://aubethermostatmanual.com>

Golf course search by state

<http://golfingnear.com>

Email search by domain

<http://emailbydomain.com>

Auto manuals search

<http://auto.somanuals.com>

TV manuals search

<http://tv.somanuals.com>