

IRONMAN[®]

CDT

Owner's Manual CDT Elliptical

Customer Service

1.800.750.IRON

1.800.750.4766



4009 Distribution Drive
Suite 250
Garland, TX 75041

www.ironmanfitness.com

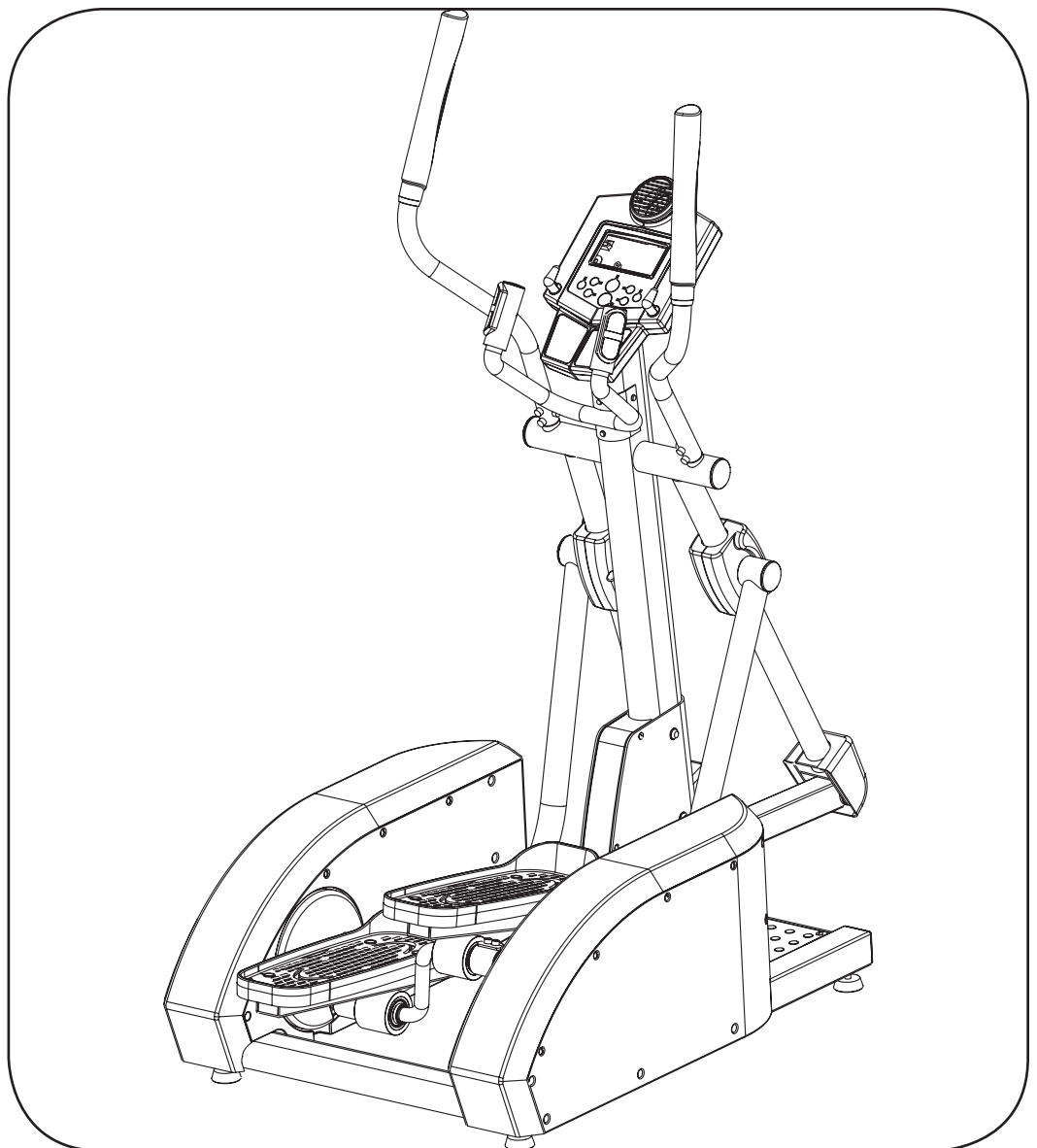

CAUTION! Read all precautions and instructions in this manual before using this equipment.

315-0085
10/06 Rev B

Table of Contents



Important Safety Information	3-4
Assembly	5-10
Console Instructions	11-16
Monitoring Your Heart Rate	17
Warm-Up Exercises	18
Troubleshooting/Cleaning/Maintenance	19
Parts List	20
Exploded Views	21
Warranty Information	22

Important Safety Information



WARNING! Before using this unit or starting any exercise program, consult your physician. This is especially important for persons over the age of 35 and/or persons with pre-existing health problems. The manufacturer or distributor assumes no responsibility for personal injury or property damage sustained by or through the use of this product.

WARNING! To reduce the risk of electrical shock, burns, fire, or other possible injuries to the user, it is important to review this manual and the following precautions before operation.

SAFETY PRECAUTIONS AND TIPS

1. It is the owner's responsibility to ensure that all users of this unit have read the Owner's Manual and are familiar with warnings and safety precautions.
2. This unit has a user maximum capacity of **300** pounds.
3. The unit should only be used on a level surface and is intended for indoor use only. The unit should not be placed in a garage, patio, or near water and should never be used while you are wet. Ironman Fitness recommends a mat be placed under the unit to protect floor or carpet and for easier cleaning.
4. Follow safety information in regards to plugging in your unit. Do not run the power cord underneath your unit. Do not operate the unit with a damaged or frayed power cord.
5. Wear comfortable, good-quality walking or running shoes and appropriate clothing. Do not use the unit with bare feet, sandals, socks or stockings.
6. Always examine your unit before using to ensure all parts are in working order.
7. Allow the unit to fully stop before dismounting.
8. Pets should never be allowed near the unit.
9. Do not leave children unsupervised near or on the unit.
10. Never operate the unit where oxygen is being administered, or where aerosol products are being used.
11. Never insert any object or body parts into any opening.
12. For safety and to prevent damage to your unit, no more than one person should use the unit at a time.
13. Always unplug the unit before cleaning and/or servicing. Service to your unit should only be performed by an authorized service representative, unless authorized and/or instructed by the manufacturer.
14. Failure to follow these instructions will void the unit warranty.

Important Safety Information



SAFETY PRECAUTIONS AND TIPS FOR CHEST STRAP

1. It is the owner's responsibility to ensure that all users of this unit have read the Owner's Manual and are familiar with warnings and safety precautions.
2. Do not place chest strap near devices that generate large magnetic fields. TV sets, electric motors, radios, and high voltage power lines can affect the transmitter's performance. These items can interfere with the heart rate signal and possibly affect the heart rate readings on the console.
3. Handle the Chest Strap with care. Dropping the transmitter might cause damage that could void the warranty.
4. Do not use the chest strap if you have a cardiac pacemaker or if you are taking medications for a heart condition. Medication or electrical pulses from the pacemaker can interfere with accurate heart rate readings.
5. Do not bend the strips inside the chest strap. This can cause the chest strap to lose conductivity.
6. The chest strap has batteries that need to be replaced periodically. A faulty battery can cause inaccurate reading.
7. It is suggested for the Chest Strap Transmitter that you position the transmitter as close to your heart as possible, against the skin, 1-2 inches below the pectoral muscles. For best results, moisten the back of the transmitter for better contact.

Assembly

Thank You for purchasing the Ironman Fitness **CDT Elliptical!** The quality product you have chosen was designed to meet your needs for cardiovascular exercise. Before you start, please read the Owner's Manual and become familiar with the operation of your new unit. Remember to take time to perform stretching exercises, provided in this manual, to help avoid injury.

If you are taking medication, consult your physician to see what affect the medication will have on your exercise heart rate.

If you have heart problems, your are not active, and/or are over the age of 35 years, do not use the pre-set programs or start an exercise program without first contacting and receiving approval from your physician.

To avoid the risk of electrical shock, always keep the console dry. Do not spill liquids on the console. Ironman Fitness recommends a sealed water bottle for beverages consumed while using the unit.

Please review the following drawing below to familiarize yourself with the listed parts.

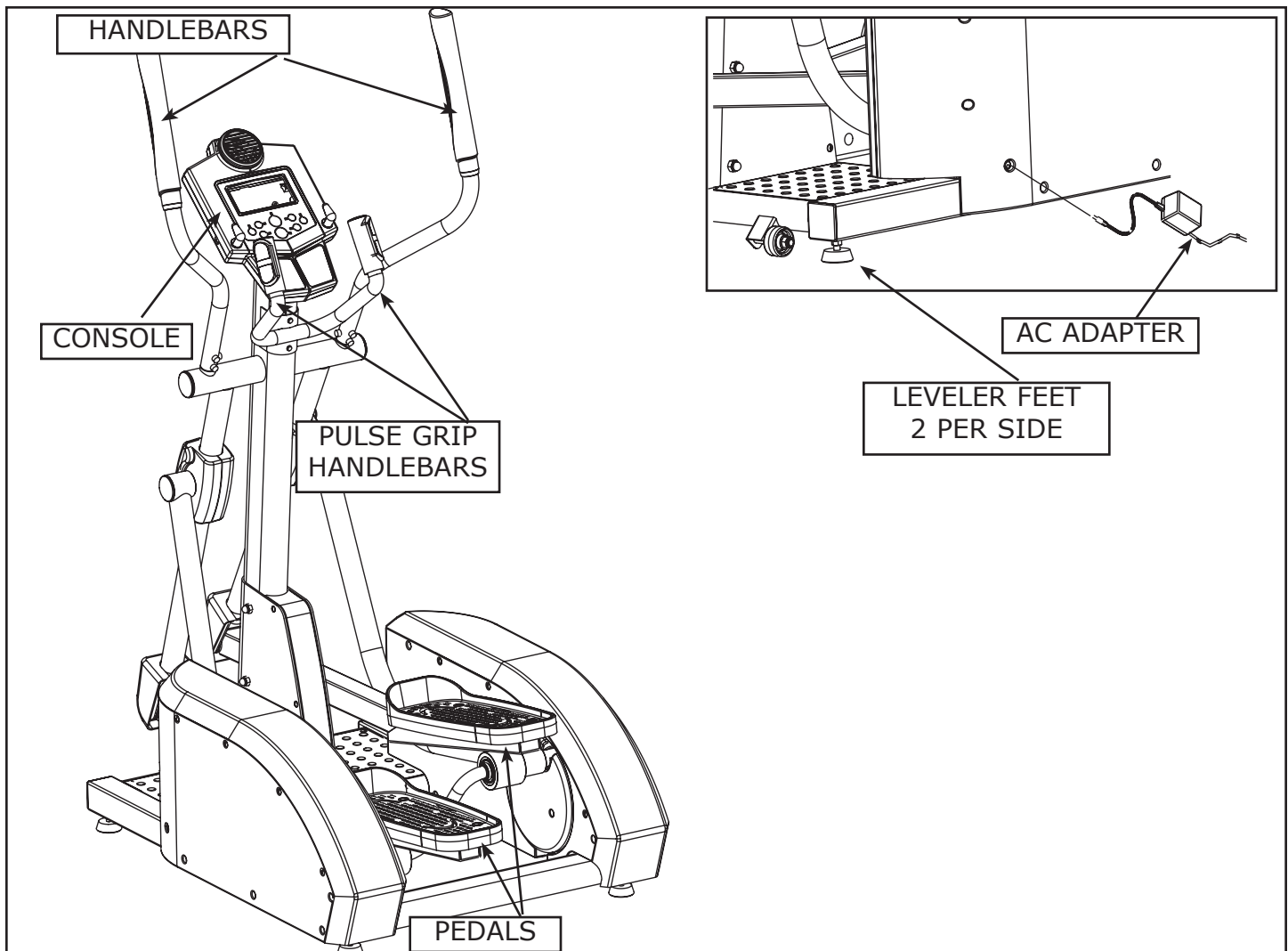

Getting Started - The Ironman Fitness CDT Elliptical will require some assembly. Unpack the box in a clear area. Remove packing material. Do not dispose of packing material until assembly is complete and unit is working properly. Place the unit on a clean level surface for assembly. Make sure there is easy access to an electrical outlet. Before assembling, the unit should be placed as close as possible to its final location. Locate all hardware bags, Labeled Figure 1 through Figure 9, with the exception of Figure 8. If you are missing any bags, please call Ironman Fitness at 1-800-750-4766. Tools have been provided for use while assembling this product.

Figure 1

Locate bag labeled Figure 1. Locate Console Tube. Attach Console Tube to Main Frame. Slide Tube down into Main Frame. Connect Upper Console Wire to Lead Wire Assembly. Secure using three M10*80 mm Hex Head Screws extending through the frame and Console Tube, three 10x20 Washers and three Crown Nuts, M10*1.5. Use three M10*120 Hex Screw to secure through the Front of the Console Tube and Main Frame.

Note: Ensure that all wires are secure inside console. Be careful not to pinch wires.

Note: Do not tighten Screws until you have fully completed Figure 2.

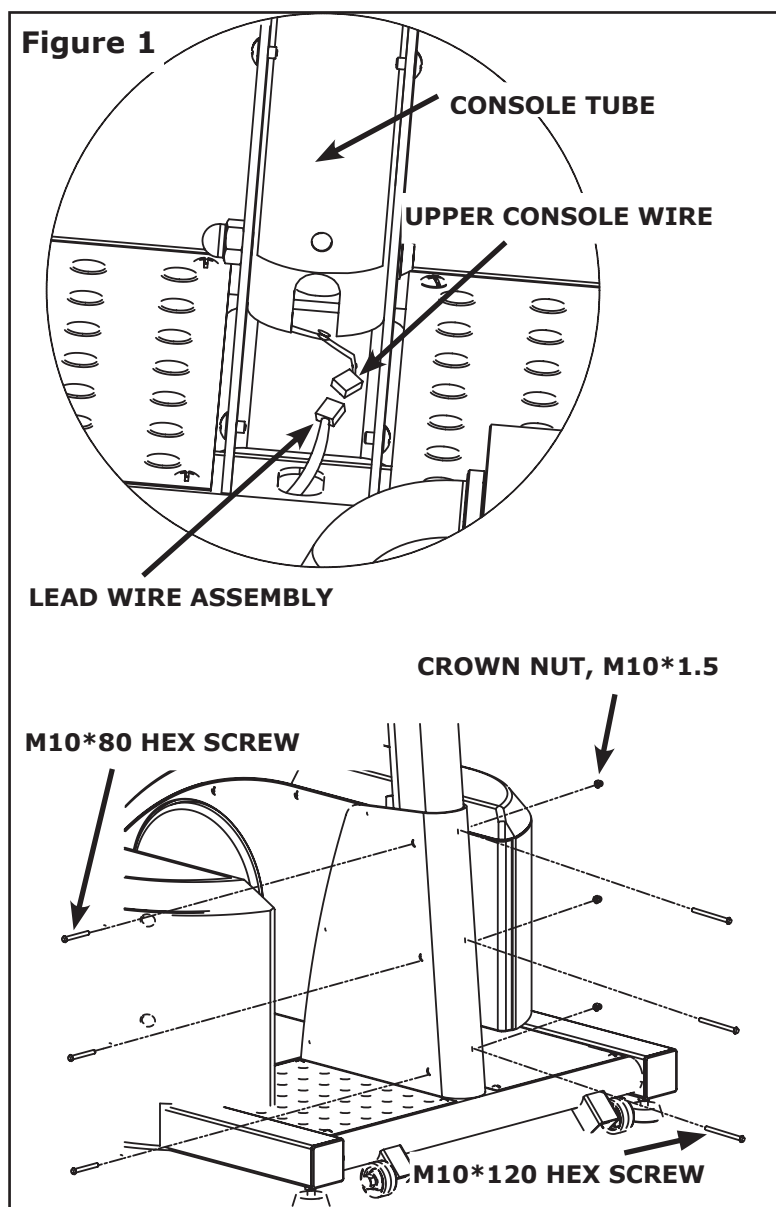

Figure 2

Locate Bag labeled Figure 2. Locate Cover. Secure Cover to Main Frame by using three M5*8 Screws through the left side of unit. Repeat for the right side.

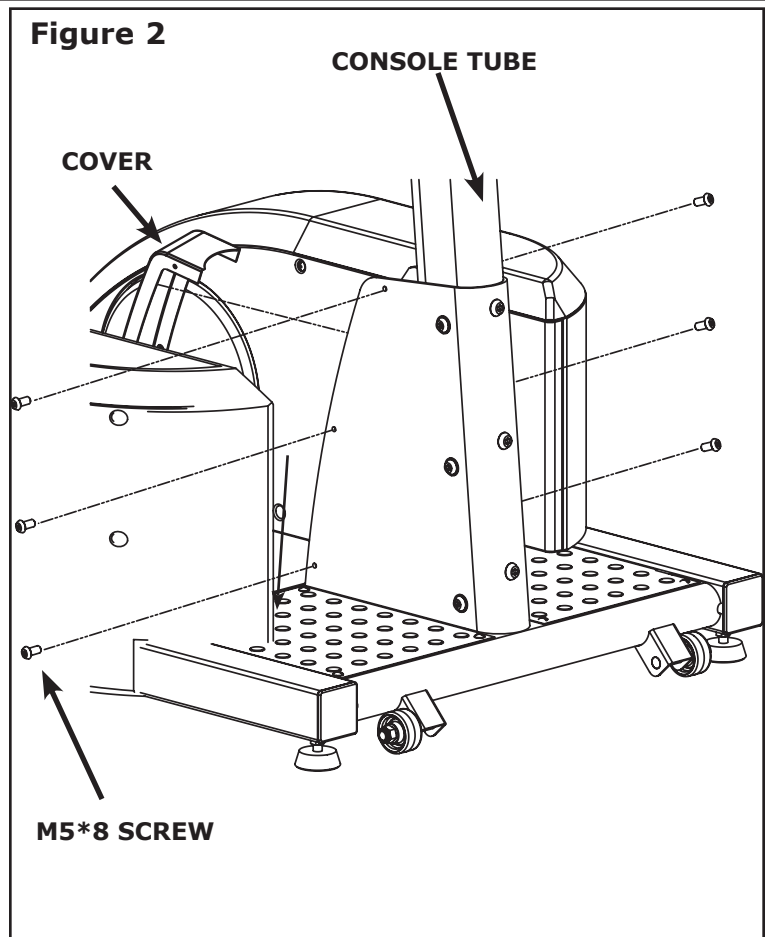

Figure 3

Locate Bag labeled Figure 3. Locate Left and Right Handrail Assemblies. Secure Left Handrail Assembly to Console tube by using one Washer, one Spring Washer, one M10*20 Hex Bolt, and one End Cap. Repeat for the right side.

Note: The Handrail Assembly will only go onto the Console Tube one way. The connector on the middle of the Handrail Assembly will face outwards.

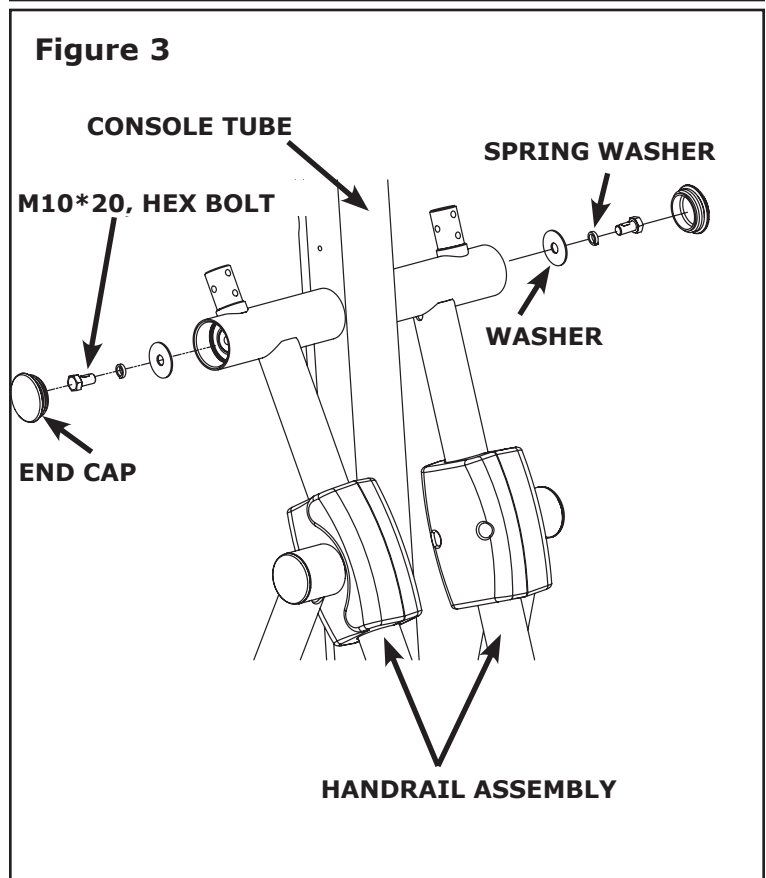

Figure 4

Locate bag labeled Figure 4. Lift and place left Linkage onto Sleeve and align holes. Secure Linkage to unit using four M8*12 mm Hex Bolts. Repeat for right side.

Note: The Linkage is secured to the sleeve with three M8*12 Hex Bolts on the top of the Linkage and one M8*12 Hex Bolt on the bottom of the Linkage.

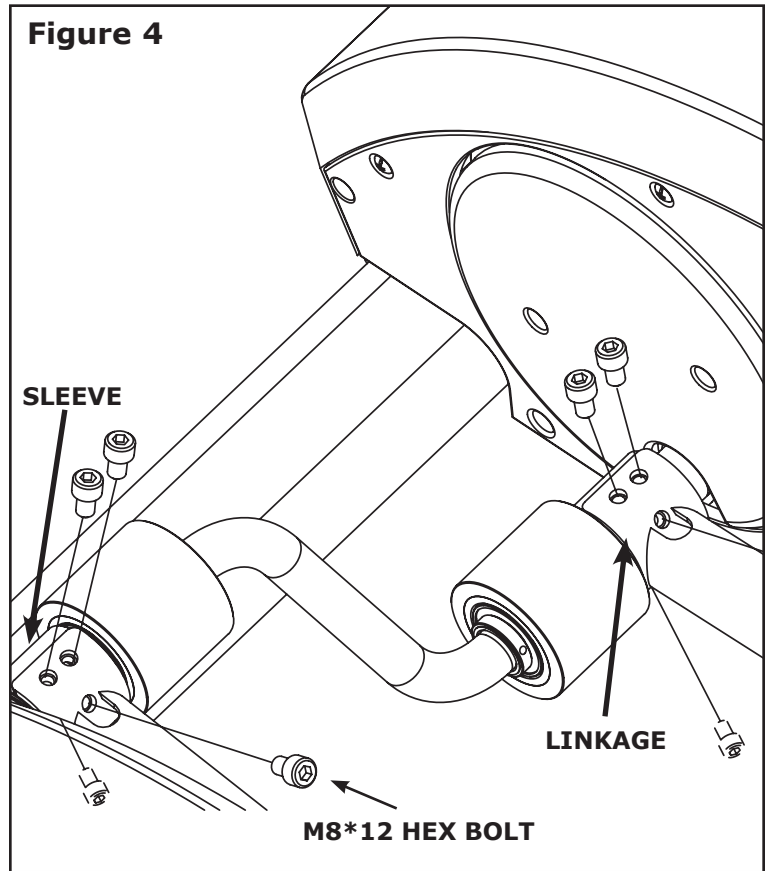

Figure 5

Locate bag labeled Figure 5. Locate Right Pedal Tube Assembly. Secure Pedal Tube assembly to the Handrail Assembly with one M10*81.5 Hex Bolt and one M10*1.5 Hex Nut. Please ensure that Pedal arm is aligned in the center of roller wheel while tightening M10*81.5 (Figure 5a). Repeat for the left side.

Note: It is recommended that 2 adults align and secure the Pedal Tube Assemblies to the Handrail Assemblies.

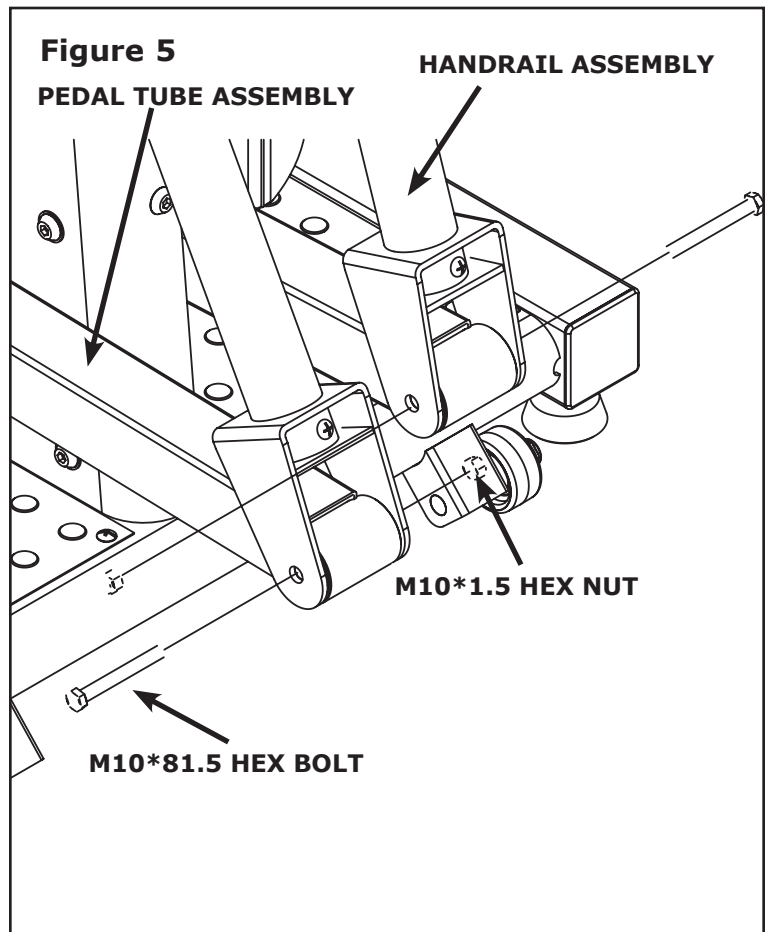

Figure 5a

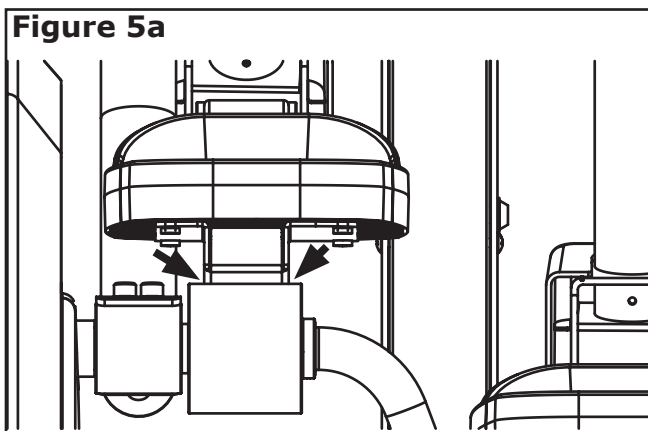

Figure 6

Locate bag labeled Figure 6. Locate Bracket Covers. Attach bracket Cover to the Handrail Assembly by lining up hole, and securing using one Screw, M5X0.8-12. Repeat for other side.

Note: Do not overtighten screw, this will damage Bracket Cover.

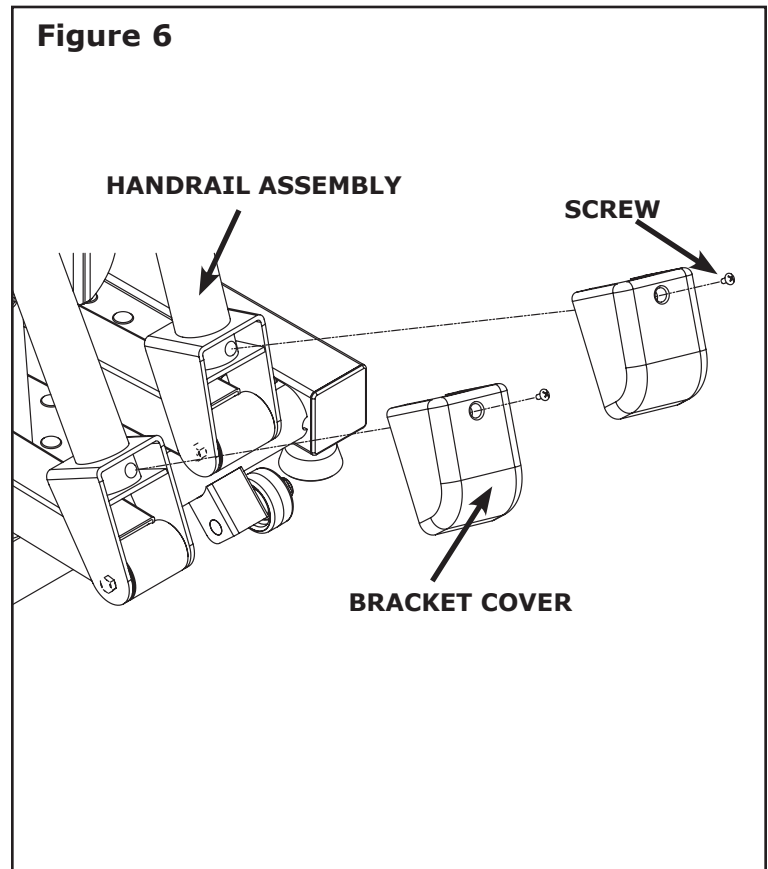

Figure 7

Locate bag labeled Figure 7. Locate Handlebars. Attach Left Handlebar to Handlebar Assy using three M8*16mm Hex Bolts. Repeat for other handlebar.

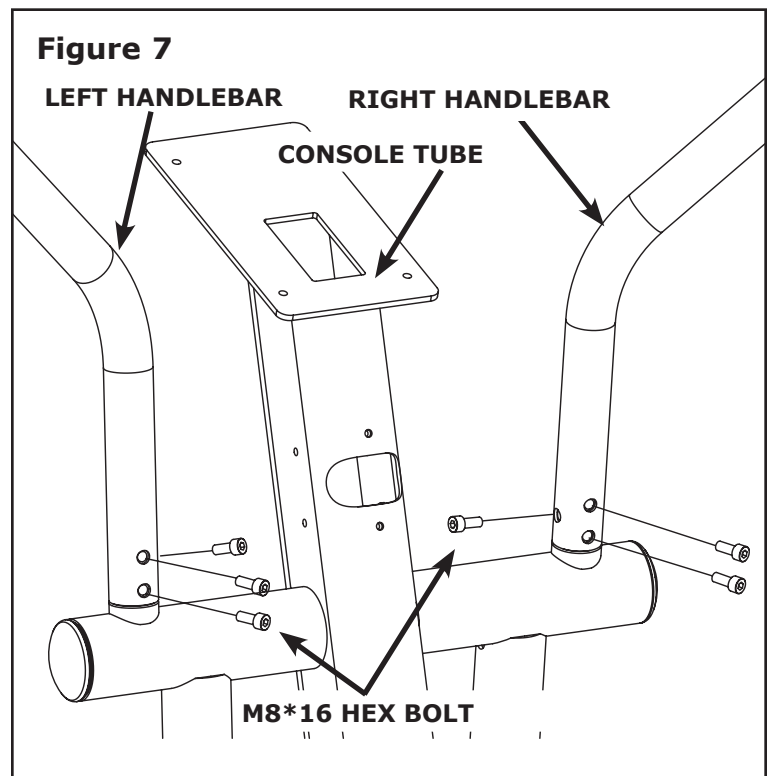

Figure 8

Locate Console. Carefully feed Pulse Wires from the Console down the Console tube. Connect Upper Console Wire to the appropriate location on the back of the Console. Secure Console to Console Tube using four Screws.

Note: The four Console Screws will already be installed into the back of Console when you remove it from the box.

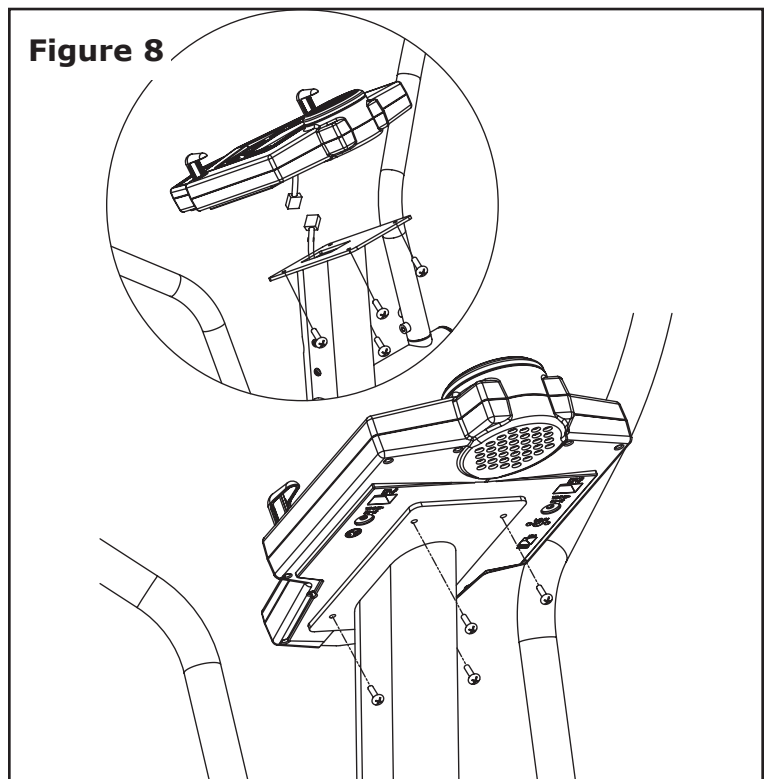
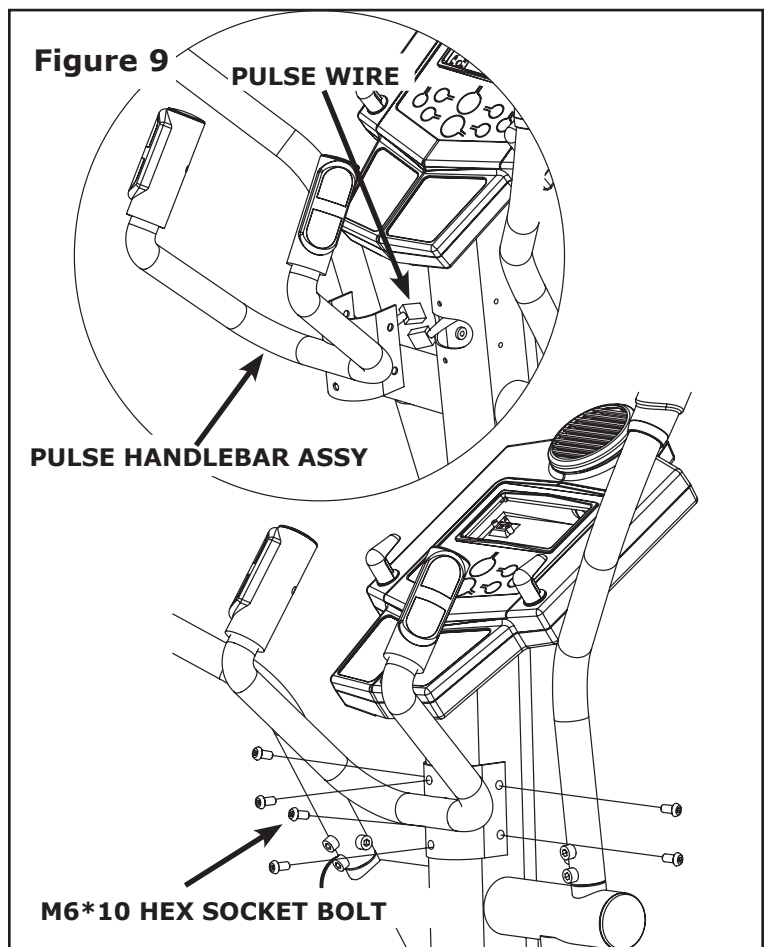

Figure 9

Locate bag labeled Figure 9. Connect the Pulse Wires coming from the Pulse Handlebar Assy to the Pulse Wires from the Console. Secure Pulse Handlebar Assembly to Console Tube using six M6*10 Hex Socket Head Bolts.

Note: Ensure that all wires are secure inside console tube. Be careful not to pinch wires.



CONGRATULATIONS!

You have completed assembly of your CDT Elliptical.

Console Instructions

Take a few moments to review the console layout. Below is an overview of the console keys and their different functions.

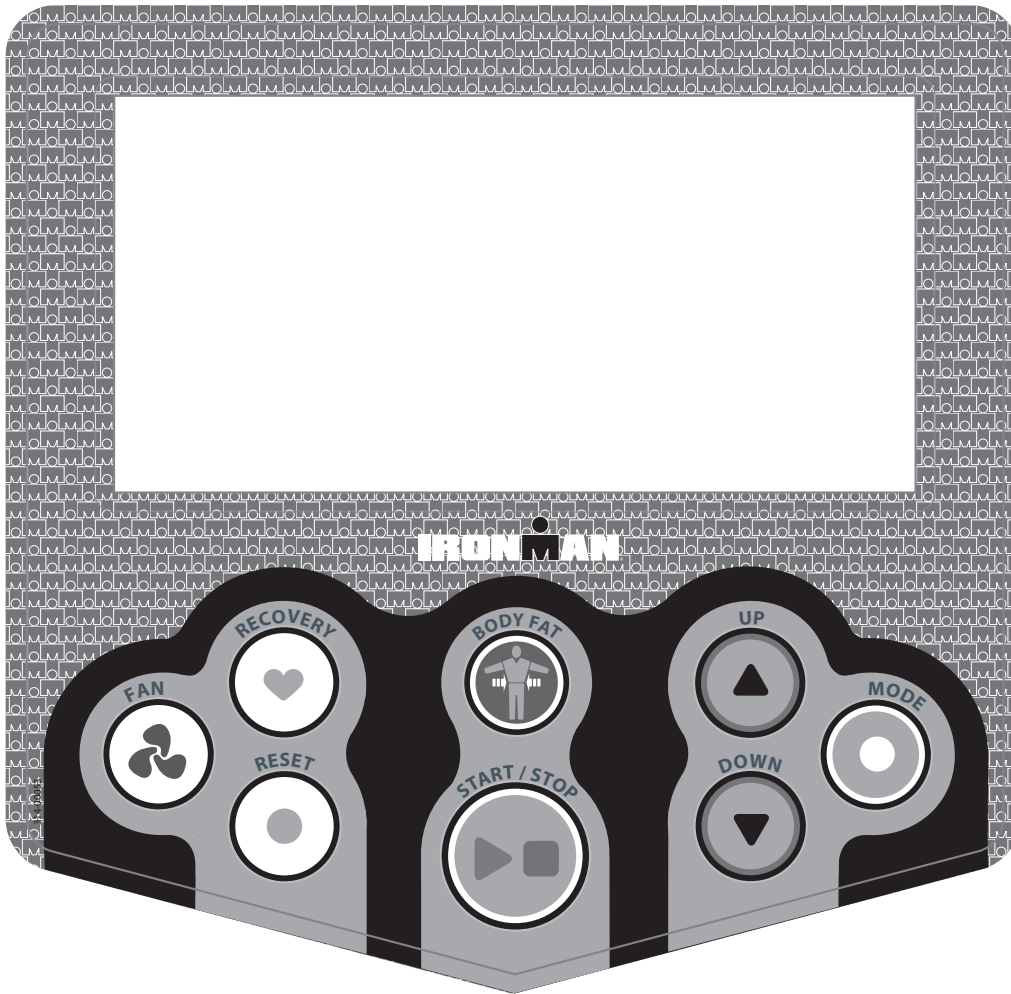

CONSOLE BUTTONS:

MODE:

To set function value for TIME, DIST, CAL, PULSE.

RESET:

Return to main function mode in STOP mode and clean all preset function values at zero.

START/STOP:

To start or stop training

RECOVERY:

To test heart rate recovery status.

UP:

To select training mode and adjust function value up.

DOWN:

To select training mode and adjust function value down.

FAN:

Console is equipped with a fan that has four settings, AUTO/LOW/MED/HIGH/OFF. Press the button to turn the fan to the preferred setting. The AUTO setting will adjust the fan speed based on the RPMs produced, the more RPMs produced the faster the fan speed will be.

BODY FAT:

Press the button to start body fat measurement.

CONSOLE FUNCTIONS

TIME:

Count up - No preset target, Time will count up from 00:00 to maximum 99:59 with each increment is 1 second. Count down - If training with preset Time, Time will count down from preset to 00:00. Each preset increment or decrement is 1 minute between 1:00 to 99:00.

SPEED:

Display current training speed from 0.0 to maximum 99.9 km or ml.

RPM:

Display current training revolutions per minute.

DISTANCE:

Count up - No preset target, Distance will count up from 0.00 to maximum 99.90 with each Increment 0.1 MPH/KM. Count down - If training with preset target, Distance will count down from preset to 0.00. Each preset increment or decrement is 0.1 KM (or ML) between 0.00 to 99.90.

CALORIES:

Count up - No preset target, Calories will count up from 0 to maximum 990 with each 1 cal increment. Count down - If training with preset target, Calories will count down from preset calories to 0. Each preset increment or decrement is 10 cal from 0 to 990 cal.

PULSE:

Displays your current heart beat figures as soon as both hands are holding the pulse sensor. The monitor will detect your heart rate through hand grip sensors or chest strap (make sure that the plug in receiver has been attached to the console), with the chest strap giving the most accurate reading.

WATT:

Display current training watt figures.

RECOVERY:

After exercising for a period of time, keep holding on handgrips and press "RECOVERY" button. All function display will stop except "TIME" starts counting down from 00:60 to 00:00. Screen will display your heart rate recovery status with the F1, F2 to F6. F1 is the best, F6 is the worst. User may keep exercising to improve the heart rate recovery status. (Press the RECOVERY button again to return the main display.)

Console Instructions



CALENDAR:

Screen will display year/month/day in sleep mode. When the unit is plugged in, the console will prompt user to input correct information. Use the UP and DOWN button until correct year is found. Press MODE to select and move on to the Month. Repeat to input correct month and day.

Note: All information will be saved until unit is unplugged.

CLOCK:

Screen will display time in sleep mode. Once the calendar is set, you will be able to input the correct time. Use the UP and DOWN buttons until the correct hour found. Press MODE to select and move on to the minutes. Repeat for to input correct minutes. **Note:** All information will be saved until unit is unplugged.

TEMPERATURE:

Screen will display room temperature in sleep mode.

GENERAL INFORMATION:

1. Start Pedaling or press any button to start Console.
2. The Console will shut down after 4 minutes of no activity, and will display room temperature.
3. To Reset Console press and hold the START/STOP button for 2 seconds.

Note: The values calculated or measured by the console are for exercise purposes only, not for medical purposes.

BMR:

Basal Metabolic Rate (metabolism) is the energy (measured in calories) expended by the body at rest to maintain normal body functions.

BMI:

Stands for Body Mass Index. BMI is a measure which takes into account a person's weight and height to gauge total body fat in adults.

GETTING STARTED:

Press the MODE button. Press MODE to enter USER SELECT. Use the UP/DOWN to select a User. Press MODE to select a User. Press the UP/DOWN key to select HEIGHT. Press MODE to confirm the value. Use the UP/DOWN key to select WEIGHT. Press MODE to confirm value. Use the UP/DOWN key to select AGE. Press MODE to confirm value. Use the UP/DOWN key to select GENDER. Press MODE to confirm value. Press START/STOP to enter program mode.

PROGRAM INSTRUCTIONS:

MANUAL PROGRAM:

Allows the User to manually adjust tension settings throughout their workout. The default tension level is 1. You may set Time or Distance for your workout.

Use the UP/DOWN buttons to scroll to this program. Press MODE to select this program. TIME will flash in the display. Use the UP/DOWN keys to set desired TIME. Press MODE to confirm value. Repeat steps for DISTANCE and KCAL. Press START/STOP to begin exercising. Grasp Pulse Grips loosely with both hands to activate PULSE function. You can change the tension level at any time during your workout session by pressing the UP/DOWN buttons.

PRESET PROGRAMS:

Each Program is divided into ten intervals.

Use the UP/DOWN buttons to scroll to this program. Press MODE to select this program. TIME will flash in the display. Use the UP/DOWN keys to set desired TIME. Press MODE to confirm value. Repeat steps for DISTANCE and KCAL. Press START/STOP to begin exercising. Grasp Pulse Grips loosely with both hands to activate PULSE function.

USER PROGRAM:

It allows you to customize a workout session. This program is divided into 10 intervals. TIME, DISTANCE, KCAL and Tension can be set for each interval. The program will be stored in the Console's memory after set-up.

Use the UP/DOWN buttons to scroll to this program. Press MODE to select this program. TIME will flash in the display. Use the UP/DOWN keys to set desired TIME. Press MODE to confirm value. Repeat steps for DISTANCE and KCAL. Column 1 will flash on display. Use the UP/DOWN keys to set Tension for this interval. Press ENTER to confirm value. Repeat for Interval 2-10. Press START/STOP to begin exercising. Grasp Pulse Grips loosely with both hands to activate PULSE function. You can change the tension level at any time during your workout session by pressing the UP/DOWN buttons. If the tension level is changed during your exercise session, this new value will not be saved into the console.

To make a permanent change, you must call up program again and repeat steps for each interval with new tension settings.

WATT PROGRAM:

In the program, the WATT function will keep a constant value. This means that if you pedal quickly, the tension will decrease, if you pedal slowly the tension will increase to maintain the Watt value entered.

$WATT = TORQUE (KGM) * RPM * 1.03$. For this program you must choose to set a TIME or a DISTANCE. Use the UP/DOWN buttons to scroll to this program. Press MODE to select this program. TIME will flash in the display. Use the UP/DOWN keys to set desired TIME. Press MODE to confirm value. Repeat steps for DISTANCE, KCAL and WATT. Press START/STOP to begin exercising. Grasp Pulse Grips loosely with both hands to activate PULSE function.

HEART RATE PROGRAMS:

Heart rate control programs are designed to automatically adjust the elliptical's resistance to keep your heart rate at a predetermined level based on the selected Heart Rate program. Each Heart Rate program is designed with a specific goal.

Console Instructions

In all Heart Rate Control programs, the console only accepts the heart rate signal from the chest strap transmitter. Make sure that the Heart Rate Receiver is plugged into the side of the Console. The chest strap will not function if it is not plugged in. Once the Heart Rate Receiver is plugged in, the pulse grip heart rate function is disabled. The requirement to wear the chest strap is due to the superior accuracy of a chest strap transmitter compared to the pulse grip sensors.



Proper Installation of Heart Rate Receiver

It is suggested on the Chest Strap Transmitter positioning that you place the transmitter as close to your heart as possible, against the skin about 1-2 inches below the pectoral muscles. For best results, moisten the back of the transmitter for better contact.

There are three Heart Rate Programs. 60% HRC (Heart Rate Control), 75% HRC and 85% HRC. The Console will adjust the Tension to keep you within your Target Heart Rate \pm 5. Example: The tension will increase if your Heart Rate is below the Target Heart Rate. The tension will decrease if your Heart Rate is higher than your Target Heart Rate.

Press MODE until Program number shows on display. Use the UP/DOWN buttons to scroll to this program. Press MODE and set values for TIME, DISTANCE, KCAL, AGE and TARGET HEART RATE. Use the UP/DOWN keys to adjust the values. Press MODE after correct value shows on display. Press START/STOP to begin exercising. Grasp Pulse Grips loosely with both hands to activate PULSE function. You may also choose the TARGET HEART RATE WORKING PROGRAM under the 3 main HEART RATE PROGRAMS. This allows the user to set a TARGET HEART RATE to exercise at for a period of TIME or a set DISTANCE.

BODY FAT PROGRAM:

This program is designed to calculate body fat ratio and to design a specific tension profile. In order to use this program correctly, make sure the personal data has been input and correct. Press the BODY FAT button, and hold on to the hand grips to start body fat testing. The console will display "- - - - -" while testing is in progress. After 8 seconds, you will see the BODY FAT in percentage and BMI. If the console has experienced an error, it will display one of the following error codes:

"E-1" - When the console displays this error, it means you did not put your hands properly on the sensor. Please try again.

"E-4" - When the console displays this error, it means that the BODY FAT is out of range.

After BODY FAT testing is completed, press the BODYFAT button to continue workout.

Note: For a more accurate reading, hold the handgrip with both hands. This is especially important in Heart Rate Mode or when performing Body Fat or Fitness Test.

Body Fat

Body Type	Female	Male
Athlete	<17%	<10%
Lean	17-22%	10-15%
Average	22-25%	15-18%
Above Avg	25-29%	18-20%
Overweight	29-35%	20-25%
Obese	35+%	25+%

Body Mass Index

Body Type	Range
Underweight	<18.5
Ideal	18.5-25
Overweight	25-30
Obese	>30

FITNESS TEST: (Pulse Recovery Feature)

The fitness test compares your pulse rate before and after training. You will notice that your fitness will improve with regular exercise.

Press the PULSE RECOVERY button immediately after your workout. Grasp the Pulse Grips. Timer will count down from 60 seconds. Your personal fitness will display on the screen. (F1-F6)

- F1 = Excellent
- F2 = Good
- F3 = Fair
- F4 = Below Average
- F5 = Poor
- F6 = Very Poor

Monitoring Your Heart Rate

Monitoring Your Heart Rate

To obtain the greatest cardiovascular benefits from your exercise workout, it is important to work within your target heart rate zone. The American Heart Association (AHA) defines this target as 60%-75% percent of your maximum heart rate.

Your maximum heart rate may be roughly calculated by subtracting your age from 220. Your maximum heart rate and aerobic capacity naturally decreases as you age. This may vary from one person to another, but use this number to find your approximate effective target zone. For example, the maximum heart rate for an average 40 year-old is 180 bpm. The target heart rate zone is 60%-75% of 180 or 108-135 bpm. See **Fitness Safety** below.

Before beginning your workout, check your normal resting heart rate. Place your fingers lightly against your neck, or against your wrist over the main artery. After finding your pulse, count the number of beats in 10 seconds. Multiply the number of beats by six to determine your pulse rate per minute. We recommend taking your heart rate at these times; at rest, after warming up, during your workout and two minutes into your cool down, to accurately track your progress as it relates to better fitness.

During your first several months of exercising, the AHA recommends aiming for the lower part of the target heart rate zone-60%, then gradually progressing up to 75%. According to the AHA, exercising above 75% of your maximum heart rate may be too strenuous unless you are in top physical condition. Exercising below 60% of your maximum will result in minimal cardiovascular conditioning.

Check your pulse recovery rate – If your pulse is over 100 bpm five minutes after you stop exercising, or if it's higher than normal the morning after exercising, your exertion may have been too strenuous for your current fitness level. Rest and reduce the intensity next time.

Fitness Safety *The Heart Rate chart indicates average rate zones for different ages. A variety of different factors (including medication, emotional state, temperature and other conditions) can affect the target heart rate zone that is best for you. Your physician or health care professional can help you determine the exercise intensity that is appropriate for your age and condition.*

(MHR) = Maximum Heart Rate
(THR) = Target Heart Rate

220 - age = maximum heart rate (MHZ)
MHZ x .60 = 60% of your maximum heart rate.
MHZ x .75 = 75% of your maximum heart rate.
For example, if you are 30 years old, your calculations will be as follows:

220 - 30 = 190
190 x .60 = 114 (low end or 60% of MHZ)
190 x .75 = 142 (high end or 75% of MHZ)
30 year-old (THR) Target Heart Rate would be 114-142

EXERCISE GUIDELINES

WARNING! Before beginning this or any exercise program, you should consult your physician. This is especially important for individuals over the age of 35 or individuals with pre-existing health problems.

Warming up prepares the body for the exercise by increasing circulation, supplying more oxygen to the muscles and raising body temperature. Begin each workout with 5 to 10 minutes of stretching and light exercise to warm up. The photos on this page show several forms of basic stretching you may perform before your workouts. In order to achieve an adequate warm-up, perform each stretch three times.

TOE TOUCH STRETCH

Stand, bending your knees slightly and slowly bend forward from your hips. Allow your back and shoulders to relax as you reach down toward your toes as far as possible. Hold for 15 counts, then relax. This will stretch your hamstrings, back of knees, and back.



HAMSTRING STRETCH

Sit with one leg extended. Bring the sole of the opposite foot toward you and rest it against the inner thigh of your extended leg. Reach toward your toes as far as possible. Hold for 15 counts, then relax. This will stretch your hamstrings, lower back, and groin.

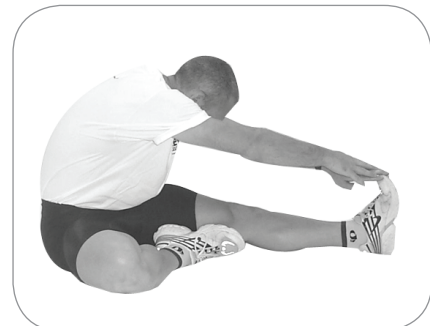

CALF/ACHILLES STRETCH

With one leg in front of the other, reach forward and place your hands against a wall. Keep your back leg straight and your back foot flat on the floor. Bend your front leg, lean forward and move your hips toward the wall. Hold for 15 counts, then relax. To cause further stretching of the Achilles tendon, bend your back leg as well. This will stretch your calves, Achilles tendons, and ankles.

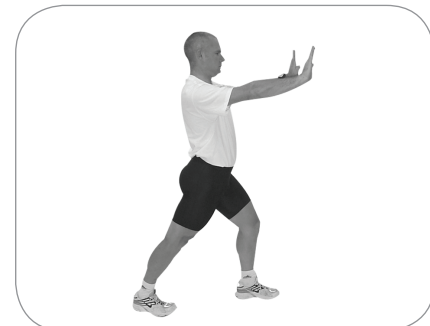

QUADRICEPS STRETCH

With one hand against a wall for balance, reach back and grasp one foot with your other hand. Bring your heel as close to your buttocks as possible. Hold for 15 counts, then relax. This will stretch your quadriceps and hip muscles.

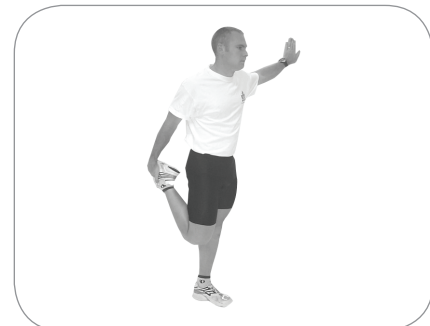

INNER THIGH STRETCH (Image not Shown)

Sit with the soles of your feet together and your knees outward. Pull your feet toward your groin area as far as possible. Hold for 15 counts, then relax. This will stretch your quadriceps and hip muscles.

Trouble Shooting Guide



Symptom	Possible Cause	Solution
Console has no power	DC adapter is not plugged into wall outlet?	Plug DC adapter into wall outlet
	DC adapter cord is not plugged into CDT?	Plug DC adapter cord into CDT power socket
	Console cable is not connected?	Verify that console cable is connected properly
	The computer is faulty?	Call the Ironman Fitness service number
Strides/Min or Speed shows 0	Computer isn't receiving a signal from the sensor?	Check that the sensor magnet is correctly fitted and passes in front of the sensor
		Check that the gap between sensor and the magnet is 3mm or less
		Check that all the computer plugs and sockets are correctly and firmly connected
		Check that the computer wires are not damaged
	The sensor is faulty?	If all above checks are okay, then replace sensor
The computer is faulty?	Call the Ironman Fitness service number	
No HR signal or incorrect HR signal	Computer is receiving a faint or intermittent pulse signal	Check that the pulse plugs are firmly inserted into the sockets
		Check to make sure that the batteries in the chest strap are installed correctly
		Replace the chest strap batteries
		Check to see if the receiver is properly installed
		Check to see if the chest strap is being properly worn by user - if skin is extremely dry, then moisten contact points on chest with water and try again
If problem still exists then call the Ironman Fitness service number		
Noise from motor	Symptoms include an unusually loud noise coming from the motor, which means the gears are not meshing correctly	Try reversing the resistance and try again. If this fails, then replace the motor.

CLEANING/MAINTENANCE -

Your CDT Elliptical has been manufactured to withstand many hours of use with minimal maintenance. It may occasionally require silicone to be sprayed on the moving parts (available at most stores).

Periodically wipe down your machine with mild, soapy water or a diluted general purpose household cleaner. Machine should be wiped down to remove sweat after each use.

CDT Elliptical Parts List Rev A

Ref #	Part #	Description	Qty	Ref #	Part #	Description	Qty
2CTS	311-00078	DRIVE PULLEY, CENTER-G/ACHIEVER	1	2D3F	305-00152	BRACKET COVER, CENTER-G/ACHIEVER/CDT	2
21K5	310-00187	MAGNET AND BRACKET, CENTER-G/ACHIEVER	1	2GVB	307-00133	AC ADAPTER, ACHIEVER/CDT	1
2DAK	304-00019	BELT, POLY-V BELT PJ450	1	21ZR	302-01353	CROWN NUT, M10*1.5-120 BLACK	3
2HRE	305-00175	COVER, SIDE LEFT TOP, CDT	1	2HT7	302-01353	CROWN NUT, M10*1.5-120 BLACK	3
2GPY	305-00174	COVER, LEFT OUTER, W/LOGO CDT	1	0J4J	302-01354	WASHER, FLAT M10*20-2	3
2GPZ	305-00169	COVER, SIDE LEFT INNER, ACHIEVER	1	2HT3	302-01355	SCREW, HEX SOC TRUSS HEAD M10*1.5-80 BLK	3
2D2K	306-00680	FLYWHEEL COVER, (NEW STYLE)	2	2EN8	302-01356	SCREW, CR.-RE TRUSS HEAD M5*0.8-8 ZINC	14
2CTM	330-00088	CENTER SHAFT ASSEMBLY, CENTER-G	2	261H	302-01357	BOLT, HEX HEAD M8*1.25-12 BLACK	8
2CTN	330-00087	CRANK SHAFT, CENTER-G/ACHIEVER/CDT	1	0JUJ	302-01358	BOLT, HEX SOC HEAD CAP M8*1.25-16 BLACK	6
2CTQ	311-00079	DRIVEN WHEEL, CENTER-G/ACHIEVER/DCT	1	0JZX	302-01359	SCREW, HEX SOC TRUSS HEAD, M6*1.0-10 BLK	6
2HRD	305-00176	COVER, SIDE RIGHT INNER, CDT	1	2CU3	302-01301	CENTER SHAFT WASHER	2
2GPW	305-00171	COVER, SIDE RIGHT INNER, ACHIEVER	1	2GQS	305-00173	COVER, ACHIEVER	1
2GPV	305-00177	COVER, SIDE RIGHT OUTER, CDT	1	2HRF	323-00429	IRON PLATE, LEFT CDT	1
0KRK	302-00144	U-TYPE NUT M5-12MM	16	2GTT	313-00368	LEAD WIRE ASSY, 1300MM ACHIEVER/CDT	1
2B5V	302-00111	CR. RE. PAN HD. SCREW M5*0.8-16MM	24	0JEJ	302-01296	C-RING A-25	4
0K94	302-00115	CR. RE. TRUSS HD. TAPPING SCREW M5*12-16	16	0KNM	302-01287	HEX. NUT, M10X1.5 CT=8	4
0K4R	302-01291	CR.-RE. TRUSS HD. SCREW M5*0.8-12	11	26LH	310-00114	LEVELER	4
21X8	302-01304	SPACER, CENTER-G/ACHIEVER/CDT	3	2GQU	306-00696	END CAP, BASE FRAME ACHIEVER/CDT	2
2H7B	306-00693	SLEEVE ASSY, ACHIEVER	1	2AX2	306-00668	TRANSPORTATION WHEEL, CENTER-G	2
2H7C	306-00694	SLEEVE, ACHIEVER	1	2HRC	323-00429	IRON PLATE, LEFT CDT	1
2HNU	319-00235	IDLER WHEEL ASSY, E06KY2	1	2HRB	323-00430	IRON PLATE, RIGHT CDT	1
21AA	319-00221	BRACKET, IDLER BELT TENSION ASSEMBLY	1	2GVA	313-00369	REED SWITCH, ACHIEVER/CDT	1
21A9	319-00236	IDLER WHEEL AXLE, ACHIEVER	1	0K3X	302-01292	CR.RE. PAN HD. SCREW & WASHER M5*0.8-14	3
21A8	319-00237	IDLER WHEEL BRACKET, ACHIEVER	1	01HL	307-00110	D.C MOTOR ASSY, CENTER-G/ACHIEVER/CDT	1
0HVY	331-00095	BALL BEARING 6204ZZ	2	2HRQ	323-00437	HANDRAIL, UPPER LEFT, CDT	1
0JEG	302-00109	C-RING A-20	1	2HRT	323-00434	PEDAL TUBE ASSY, LEFT CDT	1
22LR	302-00108	C-RING A-16	1	2HRP	323-00436	HANDRAIL, UPPER RIGHT, CDT	1
2H4J	302-01349	RETAINING RING, ACHIEVER	1	2D3C	305-00150	SHAFT COVER RIGHT, CENTER-G	2
0KNX	302-01350	HEX NUT, 3/8*24	2	2D3E	305-00151	SHAFT COVER LEFT, CENTER-G	2
0J9U	302-01351	SPRING WASHER, 3/8" BLACK	2	2HRK	323-00435	HANDRAIL ASSY, CDT	2
2H66	302-01348	M10*1.5-210, HEX HEAD BOLT	1	2D3G	306-00622	PEDALS, EVO-1, CENTER-G/ACHIEVER/CDT	2
21NP	302-01280	HEX. HD. BOLT M12*1.75-110, ZINC	2	2DBH	302-00119	CR.RE. PAN HD. SCREW & WASHER M5*0.8-20	8
2GQP	310-00193	RETAINING CLIP, ACHIEVER	2	2HRS	323-00433	PEDAL TUBE ASSY, RIGHT CDT	1
21LG	319-00225	COLLAR, CENTERG	2	2HRH	323-00432	LEFT LINKAGE ASSY, CDT	1
0KR0	302-01285	LOCKING NUT, M12*1.75 T12	6	22QV	302-01277	HEX. SOC. TRUSS HD. SCREW M10*1.5-20	2
0K2C	302-01293	HEX.SOCKET HD.CAP SCREWS M8X1.25-16	4	0J93	302-01307	SPRING WASHER, M10, BLACK	2
2GQN	311-00082	MAGNETIC BRAKE ASSY, ACHIEVER	1	2CZP	302-01295	HEX. SOC. HD. CAP BOLT M12*1.75-55 BLACK	2
2GTU	313-00366	POWER SOURCE SPCKET, 600MM ACHIEVER	1	2CTC	306-00945	COLLAR, NYLON, CENTERG/ACHIEVER/CDT	2
2GU0	307-00131	CHEST STRAP, ACHIEVER	1	2CS3	306-00669	SHAFT SLEEVE, CENTER-G/ACHIEVER/CDT	2
2HUT	307-00135	CONSOLE, CDT	1	2CU9	319-00223	COLLAR, POM, CENTERG	2
2HRJ	323-00427	HANDLEBAR ASSY W/ PULSE WIRES, CDT	1	2CU8	319-00229	SHAFT WHEEL W/BALL BEARING, NO LIP	2
2GQA	323-00412	SET PLATE, ACHIEVER	1	2DUW	302-01303	RETAINING RING, CENTER-G	2
2GTS	313-00367	UPPER CONSOLE WIRE, 2464*24AWG*1200MM	1	27JR	302-01312	HEX. SOC SET SCREW, M5*6	4
2HRL	323-00428	CONSOLE TUBE W/LOGO, CDT	1	0J4Z	302-01294	FLAT WASHER, 12X20-3	4
21B8	302-01282	HEX. HD. BOLT M10*1.5-20, ZINC	2	2CRJ	330-00087	CRANK SHAFT, CENTER-G/ACHIEVER/CDT	2
0J9C	302-01308	SPRING WASHER, M10, ZINC	2	2HRG	323-00431	RIGHT LINKAGE ASSY, CDT	1
2DM4	302-01352	WASHER, HANDLEBAR ACHIEVER/CDT	4	0K2W	302-01131	BOLT M5*12 TRI-5.3E	3
2GPG	306-00695	END CAP, HANDLEBAR ACHIEVER/CDT	4	2CU7	302-01273	HEX. HD. BOLT M10*1.5-80, BLACK	4
22RR	302-01276	HEX. NUT M10*1.5,T8 ZINC	2	2JQV	307-00134	HRC RECEIVER, ACHIEVER/CDT	1
21BA	302-01281	HEX. HD. BOLT M10*1.5-81.5	2				

Exploded View

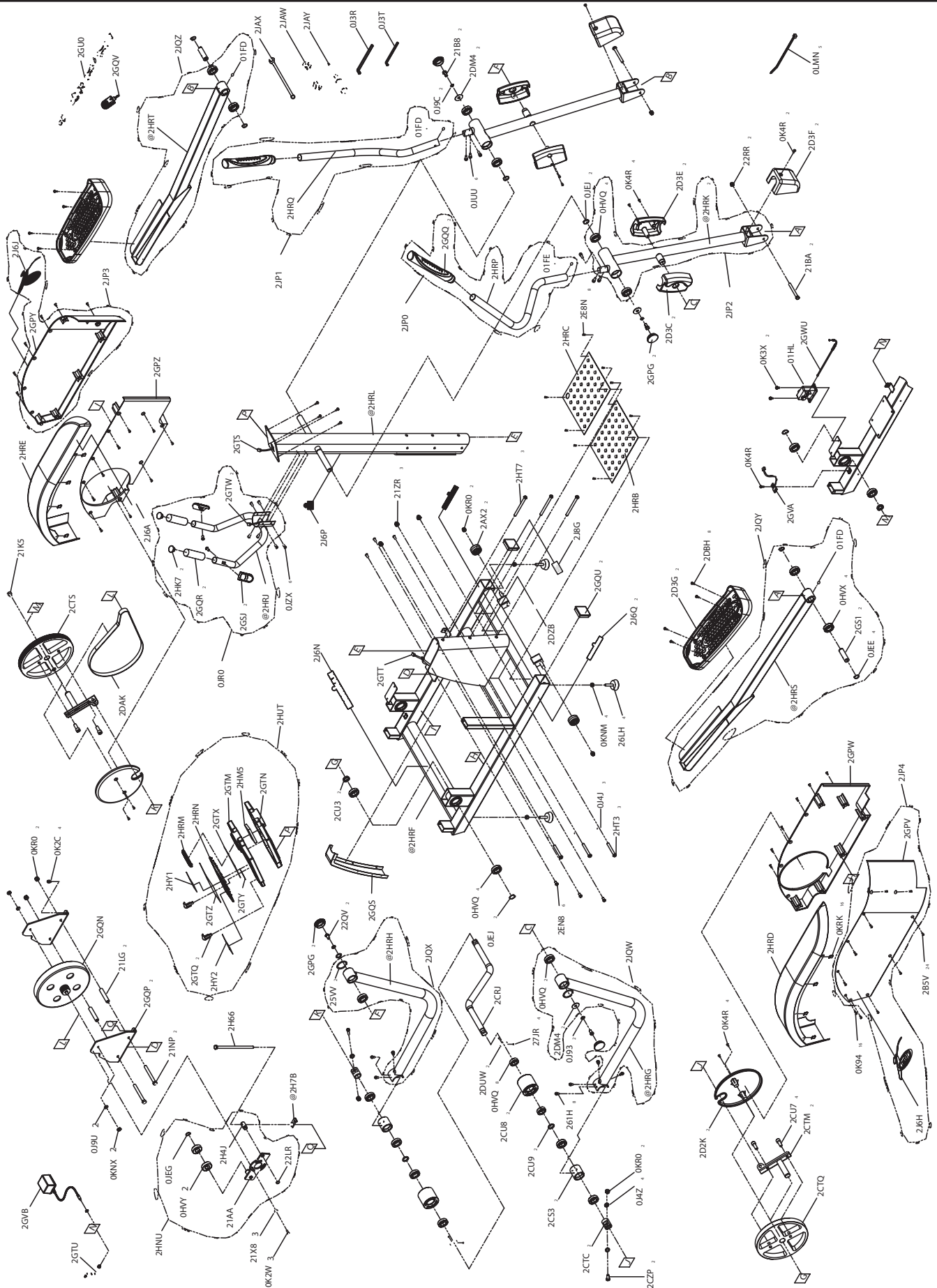

Warranty Information



Residential Warranty

Frame: Lifetime

Parts: 2 Year

Labor: 1 Year

This Limited Warranty applies in the United States and Canada to products manufactured or distributed by Ironman Fitness ("Ironman") under the Ironman brand name. The warranty period to the original purchaser is listed above in the table.

Ironman warrants that the Product you have purchased for use from Ironman or from an authorized Ironman reseller is free from defects in materials or workmanship under normal use during the warranty period. Your sales receipt, showing the date of purchase of the Product, is your proof of purchase. This warranty only extends to you, the original purchaser. It is not transferable to anyone who subsequently purchases the Product from you. It excludes expendable parts (wear items). Wear items pertain to components that might need to be replaced due to normal wear and tear. These items vary per product but will include pedal straps, seats, grips, chains, bottom bracket assemblies, pads, etc. Please contact an Ironman customer service representative for specifics on wear items. This Limited Warranty becomes VALID ONLY if the product is purchased through an Ironman Fitness authorized dealer unless otherwise authorized by Ironman Fitness in writing.

During the warranty period Ironman will repair or replace (at Ironman's option) the product if it becomes defective, malfunctions, or otherwise fails to conform with this Limited Warranty under normal use. In repairing the Product, Ironman may replace defective parts, or at the option of Ironman, serviceable used parts that are equivalent to new parts in performance. All exchanged parts and Products replaced under this warranty will become the property of Ironman. Ironman reserves the right to change manufacturers of any part to cover any existing warranty.

This warranty DOES NOT COVER shipping charges, export taxes, custom duties and taxes, or any other charges associated with transportation of the parts or Product.

To obtain warranty service, you must contact an Ironman authorized retailer, service technician or Ironman Fitness at our phone number located in this manual. Any parts determined to be defective must be returned to Ironman to obtain warranty service. You must prepay any shipping charges, export taxes, custom duties and taxes, or any other charges associated with transportation of the parts or Product. In addition, you are responsible for insuring any parts or Product shipped or returned. You assume the risk of loss during shipment. You must present Ironman with proof-of-purchase documents (including the date of purchase). Any evidence of alteration, erasing or forgery of proof-of-purchase documents will be cause to void this Limited Warranty.

This warranty does not extend to any product not purchased from Ironman or from an authorized Ironman reseller. This Limited Warranty does not extend to any Product that has been damaged or rendered defective; (a) as a result of accident, misuse, or abuse; (b) by the use of parts not manufactured or sold by Ironman; (c) by modification of the Product or normal wear and tear; (d) operation on incorrect power supplies; or (e) as a result of service by anyone other than Ironman, or an authorized Ironman warranty service provider. Product on which the serial number has been defaced or removed is not eligible for warranty service. Should any Product submitted for warranty service be found ineligible, an estimate of repair cost will be furnished and the repair will be made if requested by you upon Ironman's receipt of payment or acceptable arrangements for payment.

EXCEPT AS EXPRESSLY SET FORTH IN THIS WARRANTY, IRONMAN MAKES NO OTHER WARRANTIES, EXPRESSED OR IMPLIED, INCLUDING ANY IMPLIED WARRANTIES OF MERCHANTABILITY AND FITNESS FOR A PARTICULAR PURPOSE. IRONMAN EXPRESSLY DISCLAIMS ALL WARRANTIES NOT STATED IN THIS LIMITED WARRANTY. ANY IMPLIED WARRANTIES THAT MAY BE IMPOSED BY LAW ARE LIMITED TO THE TERMS OF THIS LIMITED WARRANTY. NEITHER IRONMAN NOR ANY OF ITS AFFILIATES SHALL BE RESPONSIBLE FOR INCIDENTAL OR CONSEQUENTIAL DAMAGES. SOME STATES DO NOT ALLOW LIMITATIONS ON HOW LONG AN IMPLIED WARRANTY LASTS OR THE EXCLUSION OR LIMITATION OF INCIDENTAL OR CONSEQUENTIAL DAMAGES, SO THE ABOVE LIMITATIONS OR EXCLUSION MAY NOT APPLY TO YOU. This Limited Warranty gives you specific legal rights and you may also have other rights that may vary from state to state. This is the only expressed warranty applicable to Ironman-brand-ed products. Ironman neither assumes nor authorizes anyone to assume for it any other express warranty.

PLEASE SEND IN THE ATTACHED WARRANTY CARD WITHIN TEN (10) DAYS OF PURCHASE TO REGISTER YOUR UNIT WITH IRONMAN FITNESS.



**Customer Service
1.800.750.IRON
1.800.750.4766**

**Ironman Fitness
4009 Distribution Drive
Suite 250
Garland, TX 75041**

www.ironmanfitness.com

Free Manuals Download Website

<http://myh66.com>

<http://usermanuals.us>

<http://www.somanuals.com>

<http://www.4manuals.cc>

<http://www.manual-lib.com>

<http://www.404manual.com>

<http://www.luxmanual.com>

<http://aubethermostatmanual.com>

Golf course search by state

<http://golfingnear.com>

Email search by domain

<http://emailbydomain.com>

Auto manuals search

<http://auto.somanuals.com>

TV manuals search

<http://tv.somanuals.com>