

Visit www.carrier.com

Installation, Start-Up, and Operating Instructions 50HX Sizes 024-060

NOTE: Read the entire instruction manual before starting the installation.

This symbol → indicates a change since the last issue.

TABLE OF CONTENTS

SAFETY CONSIDERATIONS	1
Introduction	2
RECEIVING AND INSTALLATION	2
Check Equipment.....	2
IDENTIFY UNIT	2
INSPECT SHIPMENT	2
Provide Unit Support.....	2
ROOF CURB & SLAB MOUNT.....	2
Provide Clearances.....	2
Select and Install Ductwork	2
Rig and Place Unit.....	3
INSTALLATION	5
Connect Condensate Drain	6
Install Duct Connections	7
CONFIGURING UNITS FOR DOWNFLOW (VERTICAL) DISCHARGE-STANDARD UNITS (024-042).....	8
CONFIGURING UNITS FOR DOWNFLOW (VERTICAL) DISCHARGE-ECM UNITS (048-060).....	10
Install Electrical Connection	12
HIGH-VOLTAGE & CONTROL-VOLTAGE CONNECTIONS.....	14
SPECIAL PROCEDURES FOR 208-V OPERATION	15
PRE-START-UP	19
START-UP	19
CHECK FOR REFRIGERANT LEAKS.....	19
START UP AND MAKE ADJUSTMENTS.....	20
CHECKING COOLING CONTROL OPERATION	20
CHECKING HEATING CONTROL OPERATION.....	20
CHECKING AND ADJUSTING REFRIGERANT CHARGE	20
INDOOR AIRFLOW AND AIRFLOW ADJUSTMENTS	23
For 208/230v-PSC Blower Motor.....	23
For 208/230v-ECM Blower Motor	23
COOLING SEQUENCE OF OPERATION	23
HEATING SEQUENCE OF OPERATION	25
MAINTENANCE.....	25
AIR FILTER.....	25
UNIT TOP REMOVAL	26
INDOOR BLOWER AND MOTOR.....	26
OUTDOOR COIL, INDOOR COIL, AND CONDENSATE DRAIN PAN.....	27
OUTDOOR FAN.....	30
ELECTRICAL CONTROLS AND WIRING	30
REFRIGERANT CIRCUIT.....	30
INDOOR AIRFLOW	31
METERING DEVICE — ACUTROL DEVICE	31
LIQUID LINE STRAINER	31

Troubleshooting.....	34
Start-Up Checklist.....	36

NOTE TO INSTALLER — Before the installation, READ THESE INSTRUCTIONS CAREFULLY AND COMPLETELY. Also, make sure the User's Manual and Replacement Guide are left with the unit after installation.

SAFETY CONSIDERATIONS

Installation and servicing of air-conditioning equipment can be hazardous due to system pressure and electrical components. Only trained and qualified personnel should install, repair, or service air-conditioning equipment.

Untrained personnel can perform basic maintenance functions of cleaning coils and filters. All other operations should be performed by trained service personnel. When working on air-conditioning equipment, observe precautions in the literature, tags, and labels attached to the unit, and other safety precautions that may apply.

Follow all safety codes. Wear safety glasses and work gloves. Use quenching cloth for unbrazing operations. Have fire extinguisher available for all brazing operations. Consult a qualified installer or service agency for information or assistance. The qualified installer or agency must use only factory-authorized kits or accessories when modifying this product.

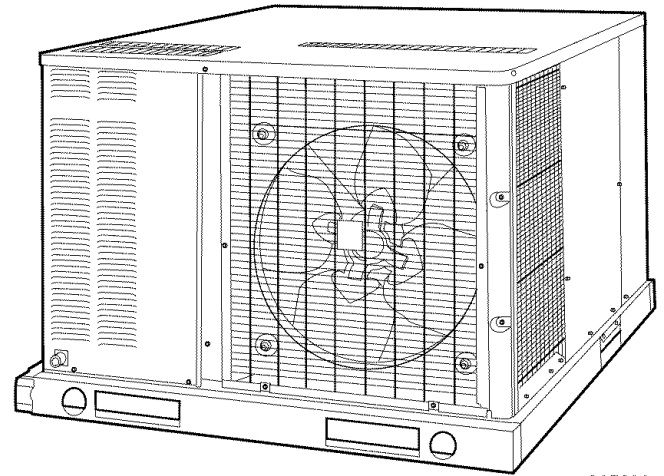

C95002

Fig. 1—Unit 50HX with Optional Base Rails

⚠ WARNING

Before performing service or maintenance operations on system, turn off power to unit. Turn off accessory heater power switch, if applicable. Electrical shock can cause personal injury.

Recognize safety information. This is the safety-alert symbol ⚠. When you see this symbol in instructions or manuals, be alert to the potential for personal injury.

Understand the signal words DANGER, WARNING, CAUTION, and NOTE. These words are used with the safety-alert symbol. DANGER identifies the most serious hazards which **will** result in severe personal injury or death. WARNING signifies a hazard which **could** result in personal injury or death. CAUTION is used to identify unsafe practices which **would** result in minor personal injury or product and property damage. NOTE is used to highlight suggestions which **will** result in enhanced installation, reliability, or operation.

These instructions cover minimum requirements and conform to existing national standards and safety codes. In some instances, these instructions exceed certain local codes and ordinances, especially those that may not have kept up with changing residential construction practices. We require these instructions as a minimum for a safe installation.

INTRODUCTION

The 50HX units (see Fig. 1) are fully self-contained, and designed for outdoor installation. See Figs. 2-5 for unit dimensions. All units are shipped in a horizontal-discharge configuration for installation on a ground-level slab. All units can be converted to down-flow discharge configurations for rooftop applications. (See Fig. 6 for roof curb dimensions.)

RECEIVING AND INSTALLATION

Step 1—Check Equipment

IDENTIFY UNIT

The unit model number and serial number are stamped on the unit identification plate. Check this information against shipping papers.

INSPECT SHIPMENT

Inspect for shipping damage while unit is still on shipping pallet. If unit appears to be damaged or is torn loose from its anchorage, have it examined by transportation inspectors before removal. Forward claim papers directly to transportation company. Manufacturer is not responsible for any damage incurred in transit. Check all items against shipping list. Immediately notify the nearest distributor if any item is missing. To prevent loss or damage, leave all parts in original packages until installation.

Step 2—Provide Unit Support

ROOF CURB & SLAB MOUNT

ROOF CURB - Install accessory roof curb in accordance with instructions shipped with curb (See Fig. 6). Install insulation, cant strips, roofing, and flashing. Ductwork must be attached to curb.

IMPORTANT: The gasketing of the unit to the roof curb is critical for a watertight seal. Install gasketing material supplied with the roof curb. Improperly applied gasketing also can result in air leaks and poor unit performance.

Curb should be level to within 1/4 in (See Fig. 8). This is necessary for unit drain to function properly. Refer to accessory roof curb installation instructions for additional information as required.

SLAB MOUNT - Place the unit on a solid, level concrete pad that is a minimum of 4 in. thick with 2 in. above grade (See Fig. 10). The slab should extend approximately 2 in. beyond the casing on

all 4 sides of the unit. Install a 6-in. gravel apron in front of outdoor coil-air inlet to prevent obstruction of airflow by grass or shrubs. Do not secure the unit to the slab except when required by local codes.

Step 3—Provide Clearances

The required minimum service clearances are shown in Fig. 2-5. Adequate ventilation and outdoor air must be provided. The outdoor fan pushes air through the outdoor coil and discharges it through the louvers on the top cover, the decorative grille, and the compressor access panel. Be sure that the fan discharge does not recirculate to the outdoor coil. Do not locate the unit in either a corner or under an overhead obstruction. The minimum clearance under a partial overhang (such as a normal house overhang) is 48 in. above the unit top. The maximum horizontal extension of a partial overhang must not exceed 48 in.

IMPORTANT: Do not restrict outdoor airflow. An air restriction at either the outdoor-air inlet or the fan discharge may be detrimental to compressor life.

Do not place the unit where water, ice, or snow from an overhang or roof will damage or flood the unit. Do not install the unit on carpeting or other combustible materials. Slab-mounted units should be at least 4 in. above the highest expected water and runoff levels. Do not use unit if it has been under water.

Step 4—Select and Install Ductwork

The design and installation of the duct system must be in accordance with the standards of the NFPA (National Fire Protection Association) for installation of nonresidence-type air conditioning and ventilating systems, NFPA90A or residence type, NFPA90B; and/or local codes and residence-type, NFPA90B; and/or local codes and ordinances. Select and size ductwork, supply-air registers and return-air grilles according to ASHRAE (American Society of Heating, Refrigeration, and Air Conditioning Engineers) recommendations. The unit has duct flanges on the supply- and return-air openings on the side of the unit. See Fig. 2-5 for connection sizes and locations. When designing and installing ductwork, consider the following:

⚠ CAUTION

When connecting ductwork to units, do not drill deeper than 1/2-in. in shaded area shown or coil may be damaged.

1. All units should have field-supplied filters or accessory filter rack installed in the return-air side of the unit. Recommended sizes for filters are shown in Table 1.
2. Avoid abrupt duct size increases and reductions. Abrupt change in duct size adversely affects air performance.

IMPORTANT: Use flexible connectors between ductwork and unit to prevent transmission of vibration. Use suitable gaskets to ensure weathertight and airtight seal. When electric heat is installed, use fireproof canvas (or similar heat resistant material) connector between ductwork and unit discharge connection. If flexible duct is used, insert a sheet metal sleeve inside duct. Heat resistant duct connector (or sheet metal sleeve) should extend 24-in. from electric heater element.

3. Size ductwork for cooling air quantity (cfm). The minimum air quantity for proper electric heater operation is listed in Table 2. Heater limit switches may trip at air quantities below those recommended.

NOTE: A 90-degree elbow must be provided in the supply ductwork to comply with UL (Underwriters' Laboratories) codes for use with electric heat.

4. Insulate and weatherproof all external ductwork. Insulate and cover with a vapor barrier all ductwork passing through

REQ'D CLEARANCES FOR SERVICING.	
INCHES (mm)	
EVAP COIL ACCESS SIDE.....	30 (762.0)
CONTROL BOX ACCESS SIDE.....	30 (762.0)
(EXCEPT FOR NEC. REQUIREMENTS)	
UNIT TOP.....	36 (914.4)
SIDE OPPOSITE DUCTS.....	30 (762.0)

REQ'D CLEARANCES TO COMBUSTIBLE MATL.	
INCHES (mm)	
UNIT TOP.....	0
DUCT SIDE OF UNIT.....	0
SIDE OPPOSITE DUCTS.....	0
BOTTOM OF UNIT.....	0
VERTICAL DISCHARGE	
FIRST 12 INCHES (304.8) OF SUPPLY DUCT....	1 (25.4)
NEC. REQ'D CLEARANCES.	
INCHES (mm)	
BETWEEN UNITS, CONTROL BOX SIDE.....	42 (1066.8)
UNIT AND UNGROUNDED SURFACES, CONTROL BOX SIDE.....	36 (914.4)
UNIT AND BLOCK OR CONCRETE WALLS AND OTHER GROUNDED SURFACES, CONTROL BOX SIDE.....	42 (1066.8)

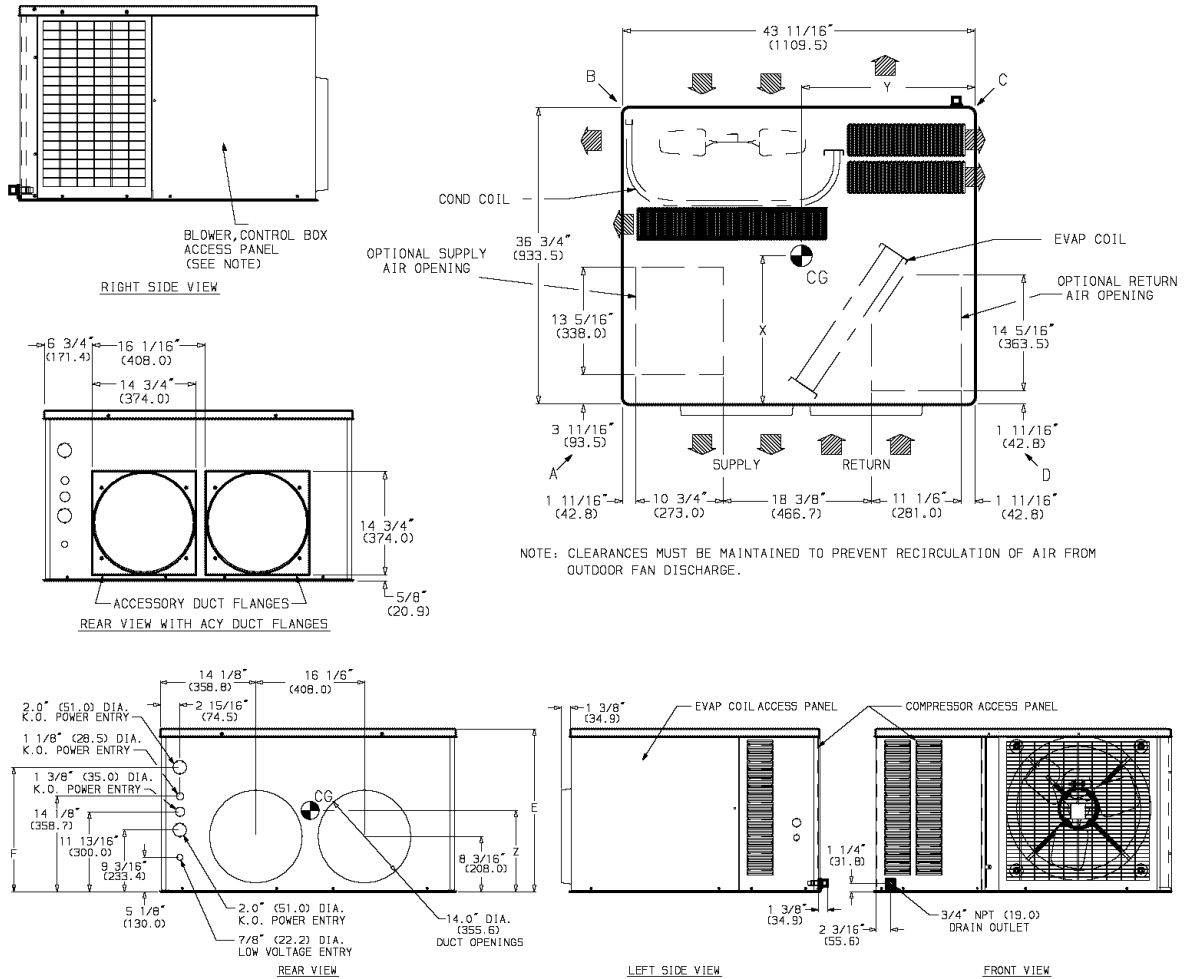

C95003

UNIT	ELECTRICAL CHARACTERISTICS	UNIT WEIGHT		CORNER WT LB/KG				CENTER OF GRAVITY IN/MM		
		lb.	kg	A	B	C	D	X	Y	Z
50HX024	208/230-1-60	257	117	57/26	69/31	75/34	56/25	20.4/519	21.1/540	11.2/286
50HX030	208/230-1-60	288	131	56/25	87/40	74/34	71/32	20.3/518	21.5/547	11.2/286

Fig. 2— 50HX024-030 Unit Dimensions (without base rails)

conditioned spaces. Follow latest Sheet Metal and Air Conditioning Contractors National Association (SMACNA) and Air Conditioning Contractors Association (ACCA) minimum installation standards for residential heating and air conditioning systems.

- Secure all ducts to building structure. Flash, weatherproof, and vibration-isolate duct openings in wall or roof according to good construction practices.

Step 5—Rig and Place Unit

Use spreader bars or crate top when rigging the unit. The units must be rigged for lifting as shown in Fig. 7. Use extreme caution to prevent damage when moving the unit. Unit must remain in an upright position during all rigging and moving operations. The unit must be level for proper condensate drainage; the ground-level pad or accessory roof curb must be level before setting the unit in

place. When a field-fabricated support is used, be sure that the support is level and that it properly supports the unit.

UNITS WITHOUT BASE RAILS-Accessory rigging brackets are recommended to be used for rigging. Install brackets as follows:

REQ'D CLEARANCES FOR SERVICING.
INCHES (mm)

EVAP COIL ACCESS SIDE.....	30 (762.0)
CONTROL BOX ACCESS SIDE.....	30 (762.0)
(EXCEPT FOR NEC. REQUIREMENTS)	
UNIT TOP.....	36 (914.4)
SIDE OPPOSITE DUCTS.....	30 (762.0)

REQ'D CLEARANCES TO COMBUSTIBLE MATL.
INCHES (mm)

UNIT TOP.....	0
DUCT SIDE OF UNIT.....	0
SIDE OPPOSITE DUCTS.....	0
BOTTOM OF UNIT.....	0
VERTICAL DISCHARGE	
FIRST 12 INCHES (304.8) OF SUPPLY DUCT....	1 (25.4)
NEC. REQ'D CLEARANCES.	
INCHES (mm)	
BETWEEN UNITS, CONTROL BOX SIDE.....	42 (1066.8)
UNIT AND UNGROUNDED SURFACES, CONTROL BOX SIDE.....	36 (914)
UNIT AND BLOCK OR CONCRETE WALLS AND OTHER GROUNDED SURFACES, CONTROL BOX SIDE.....	42 (1066.8)

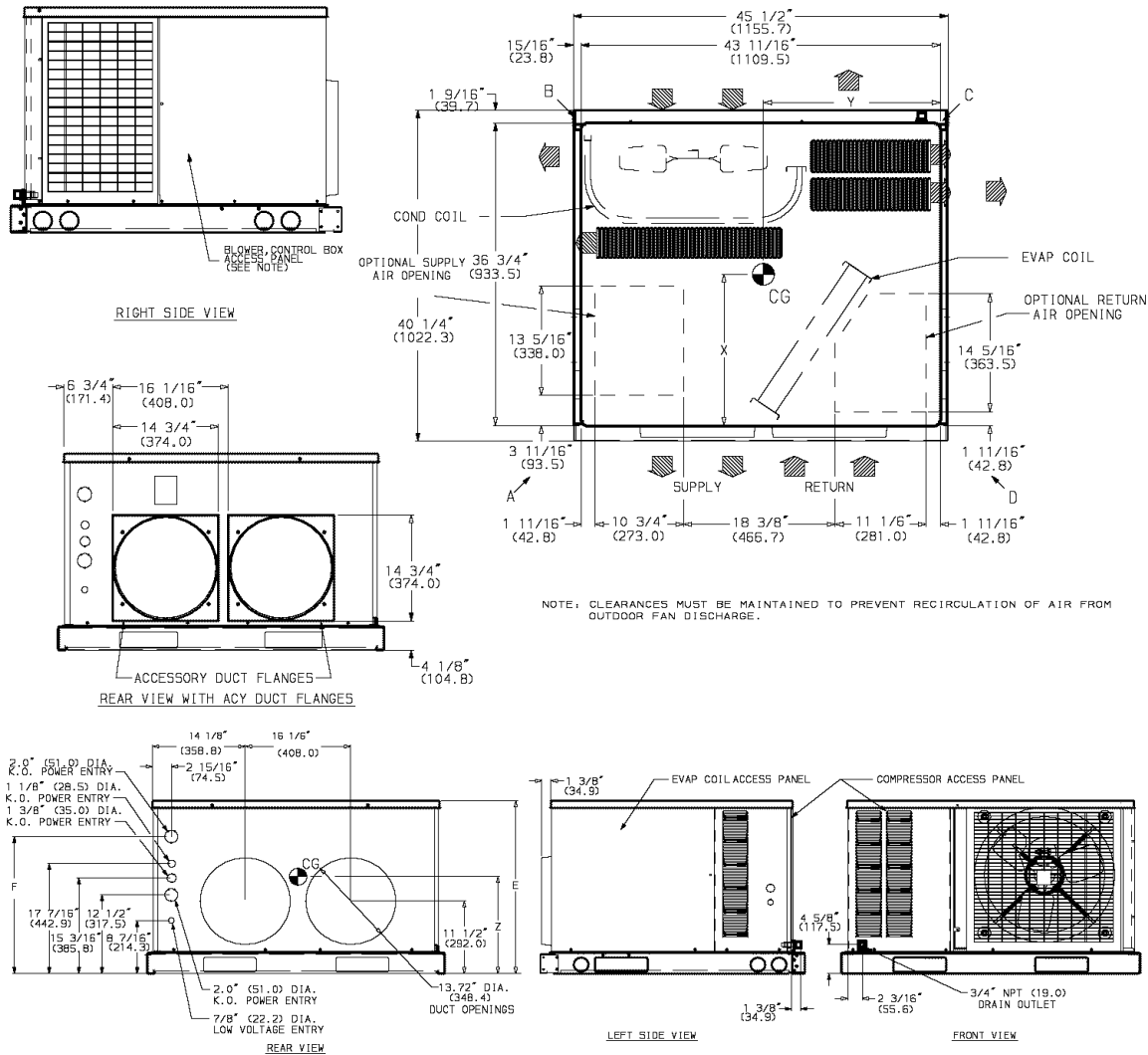

C95004

UNIT	ELECTRICAL CHARACTERISTICS	UNIT WEIGHT		CORNER WT LB/KG				CENTER OF GRAVITY IN/MM		
		lb.	kg	A	B	C	D	X	Y	Z
50HX024	208/230-1-60	277	126	62/28	74/34	80/36	61/28	20.2/515	21.3/541	13.8/351
50HX030	208/230-1-60	308	140	61/28	92/42	79/36	76/35	20.2/514	21.5/547	13.8/351

Fig. 3— 50HX024-030 Unit Dimensions (with base rails)

WARNING

Secure screws and paint protectors solidly against unit base to hold lifting brackets in position. Never use lifting brackets when the temperature is below -10 F (-23 C). Never exceed 200 lbs per bracket of lifting force. Never use lifting brackets for lifting other models of air conditioning units. Lifting point should be directly over the unit center of gravity. Failure to follow this warning could result in personal injury or death.

1. Position brackets as close to the corners of unit as possible. Be sure brackets are well outside of center of gravity (See Fig. 2-5, and 7).

2. Position paint protectors and foam strips between screws and painted surface of unit. Tighten screws until they make contact with the paint protectors.
3. Secure device or hook of sufficient strength to hole in bracket as shown in detail "C" of Fig. 7.
4. If wood top is available, use it for a spreader bar to prevent straps from damaging unit. If wood top is not available, use spreader bars of sufficient length.

UNITS WITH OPTIONAL BASE RAILS - Keep unit upright and do not drop. Use spreader bars or top crate when rigging unit. Rollers may be used to move unit across roof. Level unit for proper condensate disposal. See Fig. 7 for additional information. Lifting

REQ'D CLEARANCES FOR SERVICING
 INCHES (mm)
 EVAP COIL ACCESS SIDE.....30 (762.0)
 CONTROL BOX ACCESS SIDE.....30 (762.0)
 (EXCEPT FOR NEC. REQUIREMENTS)
 UNIT TOP.....36 (914.4)
 SIDE OPPOSITE DUCTS.....30 (762.0)

REQ'D CLEARANCES TO COMBUSTIBLE MATL.
 INCHES (mm)
 UNIT TOP.....0
 DUCT SIDE OF UNIT.....0
 SIDE OPPOSITE DUCTS.....0
 BOTTOM OF UNIT.....0
 VERTICAL DISCHARGE
 FIRST 12 INCHES (304.8) OF SUPPLY DUCT.....1 (25.4)

NEC. REQ'D CLEARANCES
 INCHES (mm)
 BETWEEN UNITS, CONTROL BOX SIDE.....42 (1066.8)
 UNIT AND UNGROUNDED SURFACES, CONTROL BOX SIDE.....36 (914.4)
 UNIT AND BLOCK OR CONCRETE WALLS AND OTHER
 GROUNDED SURFACES, CONTROL BOX SIDE.....42 (1066.8)

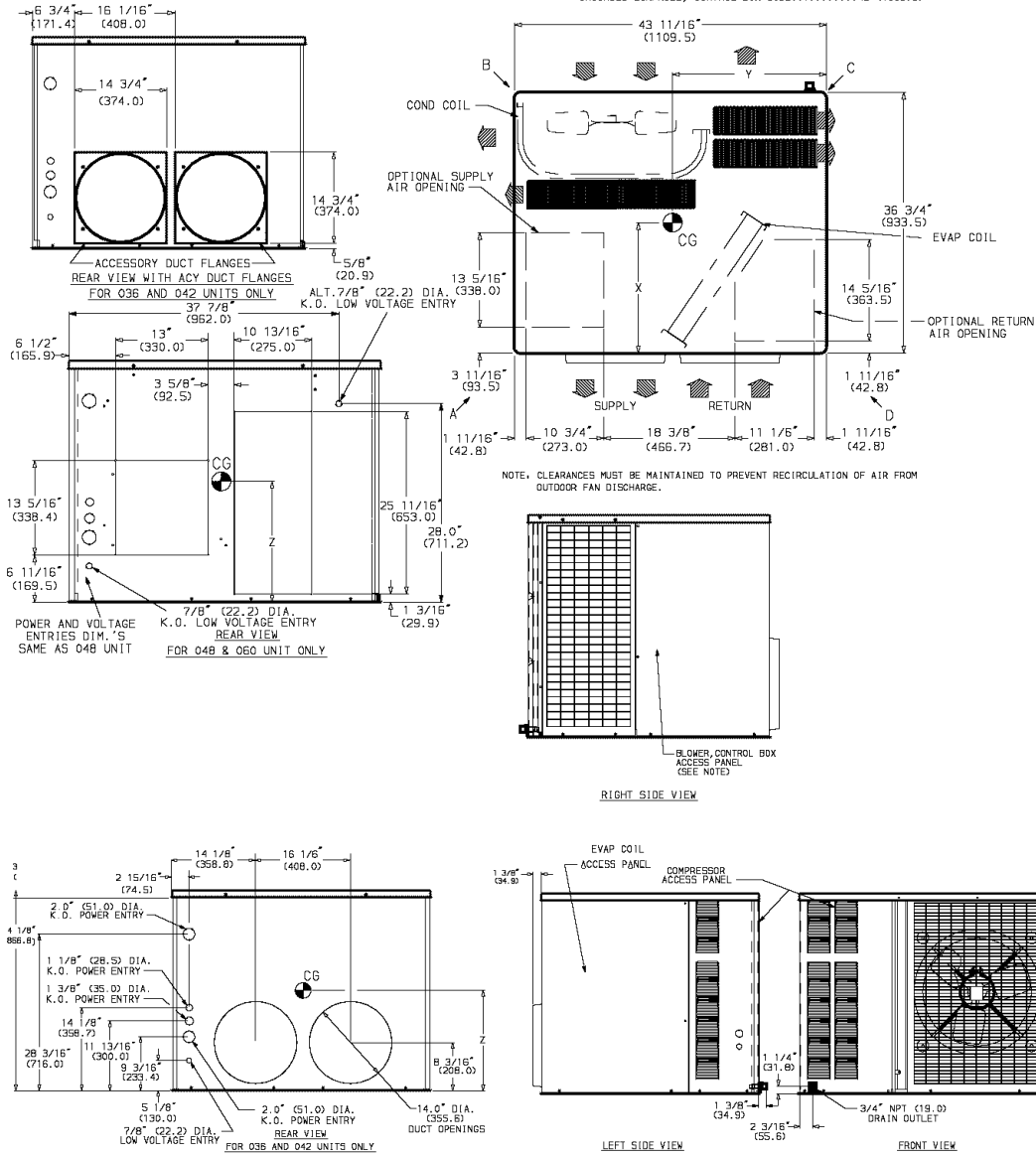

C95005

UNIT	ELECTRICAL CHARACTERISTICS	UNIT WEIGHT		CORNER WT LB/KG				CENTER OF GRAVITY IN/MM		
		lb.	kg	A	B	C	D	X	Y	Z
50HX036	208/230-1-60	316	144	46/21	103/47	81/37	86/39	21.2/539	20.4/520	13.6/347
50HX042	208/230-1-60	316	144	46/21	103/47	81/37	86/39	21.2/539	20.4/520	13.6/547
50HX048	208/230-1-60	359	163	89/40	81/37	113/51	76/35	19.7/500	20.5/522	15.0/381
50HX060	208/230-1-60,	373	170	92/42	85/39	116/53	80/36	19.6/499	20.6/523	15.0/381

Fig. 4— 50HX036-060 Unit Dimensions (without base rails)

holes are provided in base rails as shown in Fig. 7, See Detail "A" or "B-B". Refer to rigging instructions on unit.

INSTALLATION

1. Position the lifting bracket assembly around the base of the unit. Leave the top shipping skid on the unit to act as a spreader bar. Be sure the strap does not twist.
2. Place each of the four (4) metal lifting brackets into the rigging holds in the composite pan.

3. Tighten the ratchet strap unit tight. Lifting brackets should be secure in the rigging holds.
4. Attach the clevis or hook of sufficient strength to hole in the lifting bracket (See Fig. 7).
5. Attach safety straps directly to the field supplied rigging straps or clevis clip. Do not attach the safety straps to the lifting brackets.
6. Use the top of the unit as a spreader bar to prevent the rigging straps from damaging the unit. If the wood top is not available,

REQ'D CLEARANCES TO COMBUSTIBLE MATL.
INCHES (mm)

UNIT TOP.....0
DUCT SIDE OF UNIT.....0
SIDE OPPOSITE DUCTS.....0
BOTTOM OF UNIT.....0
VERTICAL DISCHARGE
FIRST 12 INCHES (304.8) OF SUPPLY DUCT.....1 (25.4)

REQ'D CLEARANCES
INCHES (mm)

BETWEEN UNITS, CONTROL BOX SIDE.....42 (1066.8)
UNIT AND UNGROUNDED SURFACES, CONTROL BOX SIDE.....36 (914.4)
UNIT AND BLOCK OR CONCRETE WALLS AND OTHER GROUNDED SURFACES, CONTROL BOX SIDE.....42 (1066.8)

REQ'D CLEARANCES FOR SERVICING
INCHES (mm)

EVAP COIL ACCESS SIDE.....30 (762.0)
CONTROL BOX ACCESS SIDE.....30 (762.0)
(EXCEPT FOR NEC. REQUIREMENTS)
UNIT TOP.....36 (914.4)
SIDE OPPOSITE DUCTS.....30 (762.0)

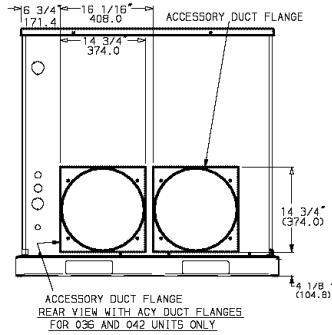

ACCESSORY DUCT FLANGE
REAR VIEW WITH ACY DUCT FLANGES
FOR 036 AND 042 UNITS ONLY

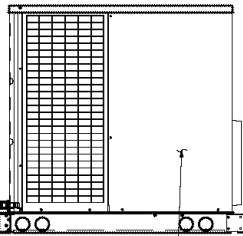

BLOWER CONTROL BOX
ACCESS PANEL
(SEE NOTE)

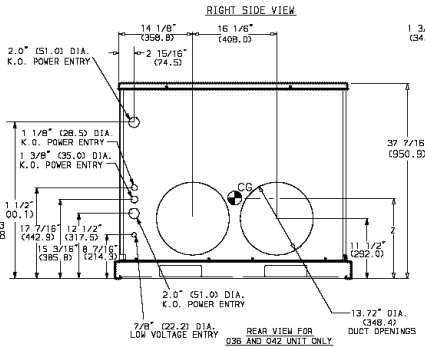

RIGHT SIDE VIEW

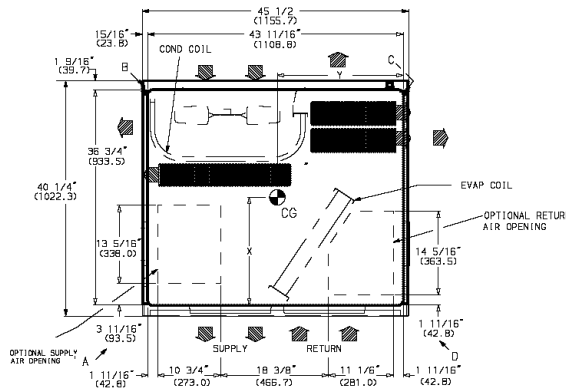

COND COIL

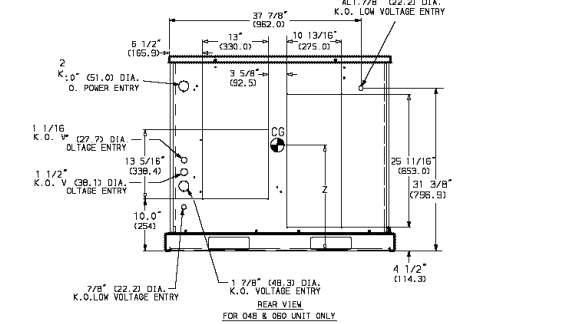

REAR VIEW
FOR 048 & 060 UNIT ONLY

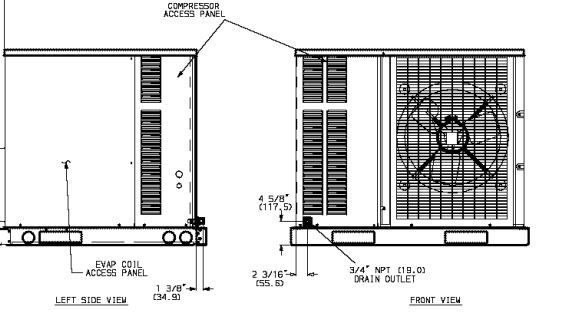

LEFT SIDE VIEW

FRONT VIEW

C95006

UNIT	ELECTRICAL CHARACTERISTICS	UNIT WEIGHT		CORNER WT LB/KG				CENTER OF GRAVITY IN/MM		
		lb.	kg	A	B	C	D	X	Y	Z
50HX036	208/230-1-60	336	153	51/23	108/49	86/39	91/41	21.0/535	20.5/521	16.4/418
50HX042	208/230-1-60	336	153	51/23	108/49	86/39	91/41	21.0/535	20.5/521	16.4/418
50HX048	208/230-1-60	379	172	94/43	86/39	118/54	81/37	19.6/498.3	20.6/524	17.3/440
50HX060	208/230-1-60,	393	179	97/44	90/41	121/55	85/39	19.5/497.3	20.6/524	17.3/440

Fig. 5— 50HX036-060 Unit Dimensions (with base rails)

use a spreader bar of sufficient length to not damage the unit.

WARNING

Lifting point should be directly over the center of gravity for the unit. Failure to follow this warning could result in personal injury or death.

Step 6—Connect Condensate Drain

NOTE: When installing condensate drain connection be sure to comply with local codes and restrictions.

Unit disposes of condensate through a 3/4-in. NPT fitting which exits through the compressor access panel. See Fig. 2-5 (Front

View) for location of condensate connection.

Condensate water can be drained directly onto the roof in rooftop installations (where permitted) or onto a gravel apron in ground-level installations. Install a field-supplied condensate trap at end of condensate connection to ensure proper drainage. Make sure that the outlet of the trap is at least 1-in. lower than the drain-pan condensate connection to prevent the pan from overflowing. Prime the trap with water. When using a gravel apron, make sure it slopes away from the unit.

If the installation requires draining the condensate water away from the unit, install a 2-in. trap using a 3/4-in. NPT connection (See Fig. 18). Make sure that the outlet of the trap is at least 1-in. lower than the unit drain-pan condensate connection to prevent the

1. ROOFCURB MUST BE SET UP FOR UNIT BEING INSTALLED.
2. SEAL STRIP MUST BE APPLIED AS REQUIRED FOR UNIT BEING INSTALLED.
3. DIMENSIONS IN [] ARE IN MILLIMETERS.
4. ROOFCURB IS MADE OF 16 GAUGE STEEL.
5. ATTACH DUCTWORK TO CURB (FLANGES OF DUCT REST ON CURB).
6. SERVICE CLEARANCE 4 FEET ON EACH SIDE.
7.  DIRECTION OF AIR FLOW.
8. INSULATED PANELS: 1" THK. FIBERGLASS 1# DENSITY.

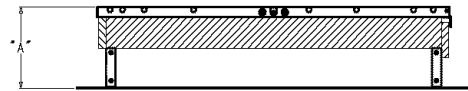

FLAT CURB

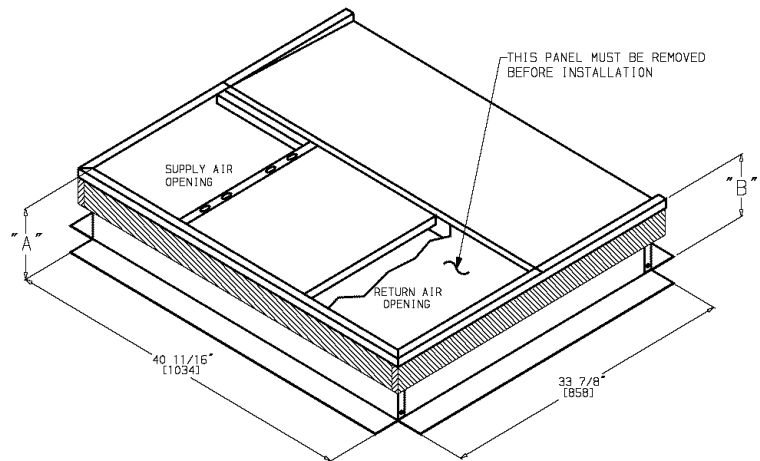
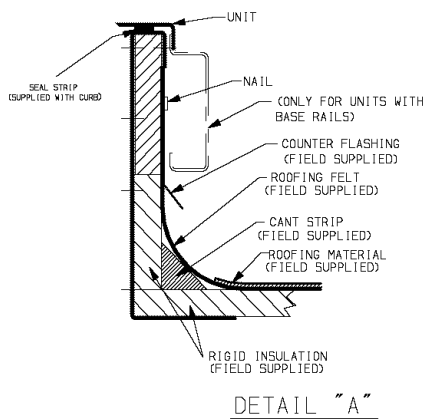
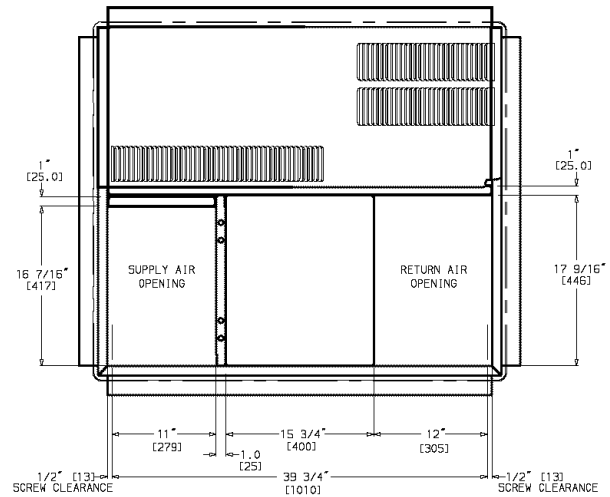
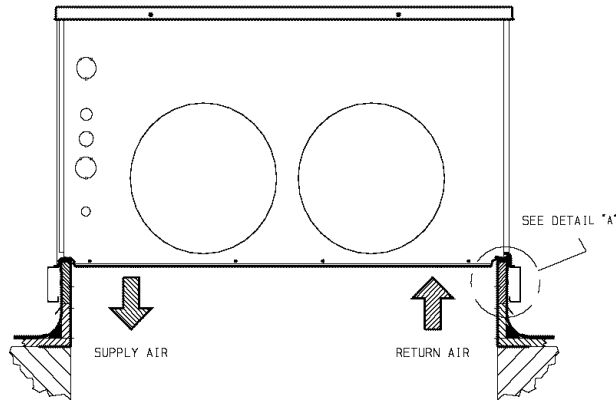

C95007

	ODS CATALOG NUMBER	A IN. (MM)
Flat Curb	CPRFCURB001A00	8 (203)
	CPRFCURB002A00	11 (279)
	CPRFCURB003A00	14 (356)

Fig. 6— Roof Curb Dimensions

pan from overflowing. Prime the trap with water. Connect a drain tube using a minimum of 3/4-in. PVC, 3/4-in. CPVC, or 3/4-in. copper pipe (all field supplied). Do not undersize the tube. Pitch the drain tube downward at a slope of at least 1 in. for every 10 ft of horizontal run. Be sure to check the drain tube for leaks. Prime trap at the beginning of the cooling season start-up.

Step 7—Install Duct Connections

The unit has duct flanges on the supply- and return-air openings on the side and bottom of the unit. For downshot applications the ductwork can be connected to the roof curb. See Fig. 2-5 for connection sizes and locations.

IMPORTANT: Use flexible connectors between ductwork and unit to prevent transmission of vibration. Use suitable gaskets to ensure weathertight and airtight seal. When electric heat is installed, use fire proof canvas (or similar heat resistant material)

connector between ductwork and unit discharge connection. If flexible duct is used, insert a sheet metal sleeve inside duct. Heat resistant duct connector (or sheet metal sleeve) must extend 24-in. from the unit discharge connection flange into the ductwork.

ACCESSORY DUCT FLANGE KIT INSTALLATION-

1. Mark hole locations (See instructions included in Flange Kit).

CAUTION

Do not drill deeper than 1/2-in. into area between round duct openings. Damage to refrigerant coil could result.

2. At marked locations, drill holes using a no. 26 (.147-in.) twist drill (See Fig. 19).
3. Partially secure duct flanges using two of the no. 10, 1/2-in. screws provided.

NOTICE TO RIGGERS

HOOK RIGGING SHACKLES THROUGH HOLES IN LIFTING BRACKETS AS SHOWN IN DETAIL "A & C". LIFTING BRACKETS TO BE CENTERED AROUND THE UNIT CENTER OF GRAVITY. USE WOODEN TOP SKID WHEN RIGGING, TO PREVENT RIGGING STRAPS FROM DAMAGING UNIT. ON UNITS WITH RAILS REMOVE FOUR SCREWS TO SLIDE WOOD SUPPORT THROUGH RECTANGULAR HOLE IN RAIL

CAUTION: ALL PANELS MUST BE IN PLACE WHEN RIGGING.

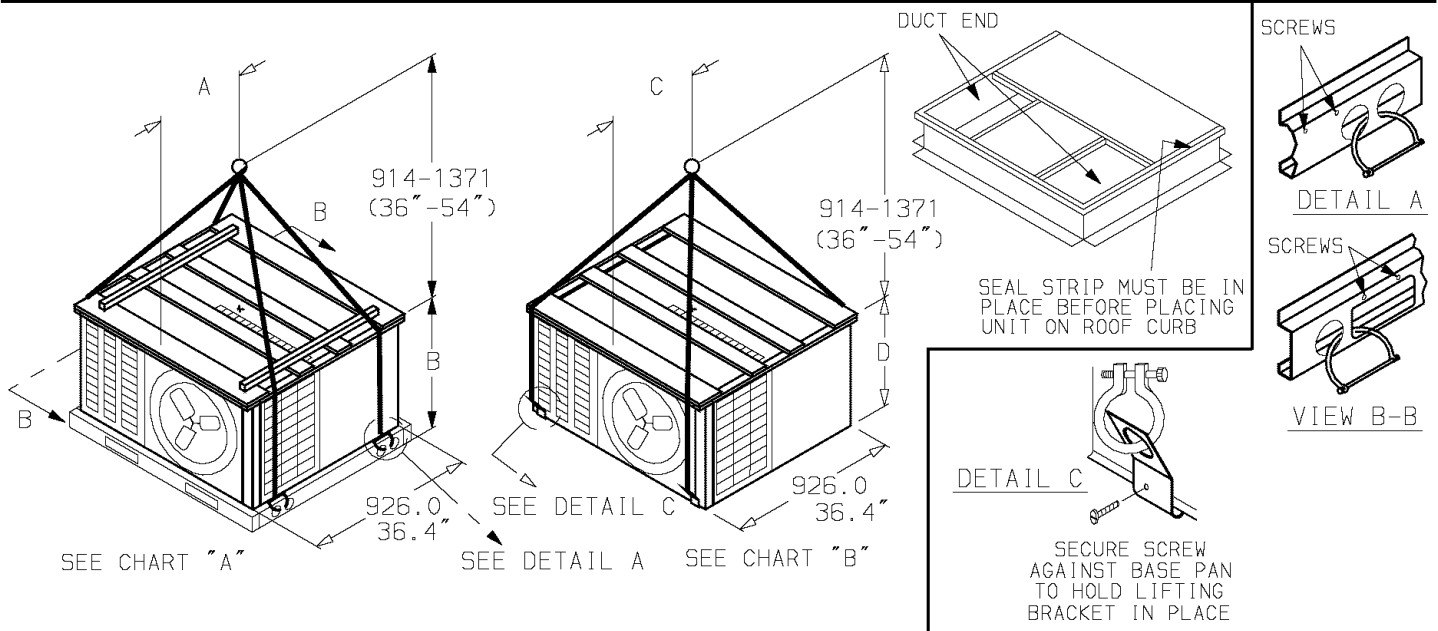

UNIT SIZE	CHART A						CHART B					
	Max Weight		A		B		Max Weight		C		D	
	LB	KG	IN	MM	IN	MM	LB	KG	IN	MM	IN	MM
024	296	134	16.1	410	32.2	817	309	140	16.0	406	28.9	733
030	327	148	16.2	411	32.2	817	340	154	16.0	407	28.9	733
036	355	161	15.4	390	38.2	969	368	167	15.2	385	34.9	885
042	355	161	15.4	390	38.2	969	368	167	15.2	385	34.9	885
048	398	180	16.9	428	38.2	969	411	186	16.8	426	34.1	867
060	412	187	16.9	429	38.2	969	425	193	16.8	427	34.1	867

Fig. 7— 50HX Rigging Instructions

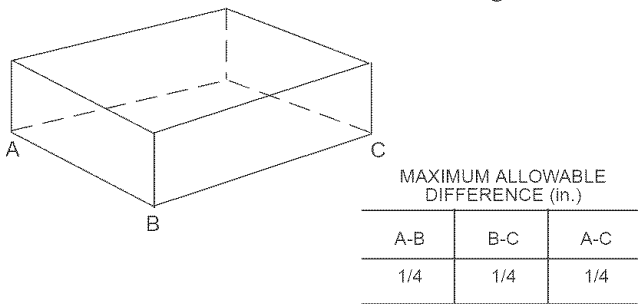

Fig. 8—Unit Leveling Tolerances

4. See the following caution. Using remaining holes in duct flanges as templates, drill the remaining holes with the no. 26 (.147-in.) drill.
5. Fully secure the duct flanges using the remaining screws provided.

NOTE: The finished kit installation accommodates a 14 3/4-in. x 14 3/4-in. duct.

CONFIGURING UNITS FOR DOWNFLOW (VERTICAL) DISCHARGE-STANDARD UNITS (024-042)

Units 024-042 (Units with PSC Indoor Blower Motors) are shipped in a horizontal configuration. To convert a horizontal unit for downflow (vertical) discharge, perform the following steps:

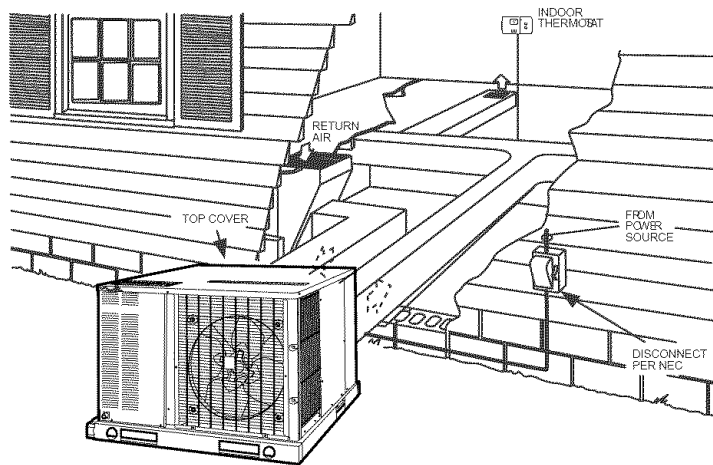

C95013

Fig. 9—Typical Unit Installation

REAR SIDE OF UNIT

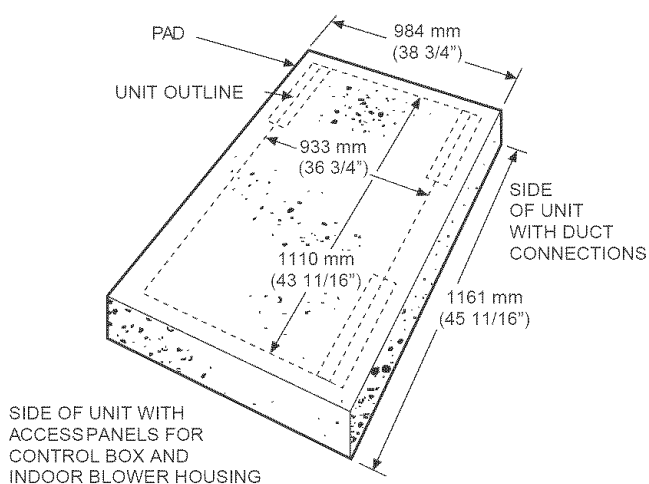

NOTES:

1. Extend 6-in. gravel apron around pad.
2. Provide a 3-ft service clearance at front and rear sides of unit.

C95039

Fig. 10—Typical Slab Layout

⚠ WARNING

Before performing service or maintenance operations on the system, turn off main power to unit and install lockout tag or electrical shock could result.

1. Open all electrical disconnects and install lockout tag before starting any service work.
2. Remove indoor coil access panel (See Fig. 12).
3. Locate lances in unit base insulation that are placed over the perimeter of the vertical duct opening cover (See Fig. 13).
4. Using a straight edge and sharp knife, cut and remove the insulation around the perimeter of the cover. Remove the screws securing the cover to the unit base and slide out the cover. Discard the cover.
5. Remove indoor blower access panel (See Fig. 14).
6. Disconnect indoor-fan motor leads from indoor fan relay and unit contactor (See Fig. 15). Carefully disengage wire tie containing indoor-fan motor leads from the unit control box (See Fig. 15 & 17).
7. Remove screws securing indoor blower housing to blower shelf and carefully slide out blower housing. There is a filler

bracket attached to the blower shelf; remove this filler bracket and retain for later use (See Fig. 16).

8. Locate lances in unit base insulation that are placed over the perimeter of the vertical discharge opening cover (See Fig. 13).
9. Using a straight edge and sharp knife, cut the insulation around the perimeter of the cover. Remove the screws securing the cover to the unit base and slide out the cover. Discard the cover. Install filler bracket removed in Step 7.
10. If unit ductwork is to be attached to vertical opening flanges on the unit base (jackstand applications only), do so at this time.
11. It is recommended that the unit base insulation around the perimeter of the vertical opening be secured to the unit base with aluminum tape to prevent the insulation from tearing or bunching up when the blower housing is installed in the vertical discharge position.
12. Orient blower housing for vertical airflow (blower motor adjacent to horizontal duct opening) and slide into vertical opening making sure the flanges on the blower side plates engage the tabs in the unit base (See Fig. 15). Resistance will be felt as the blower housing contacts the unit base insulation;

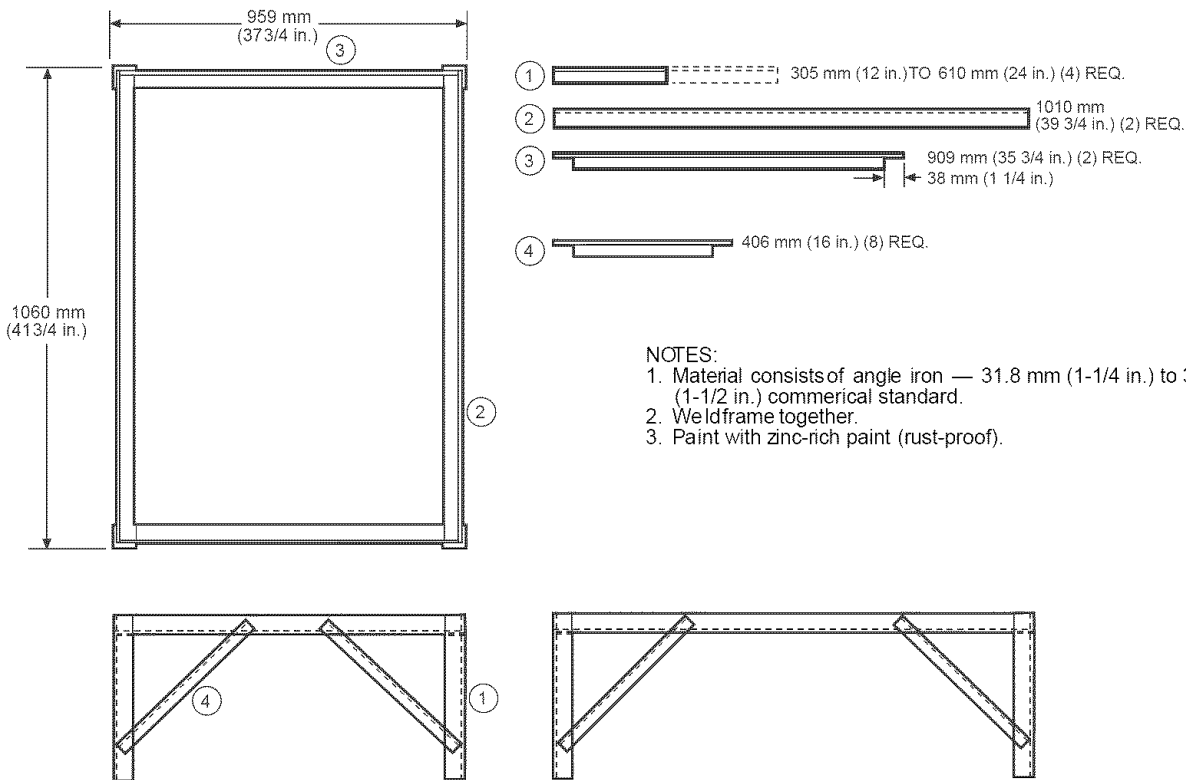

Fig. 11—Optional Heat Pump Mounting Frame

C95013

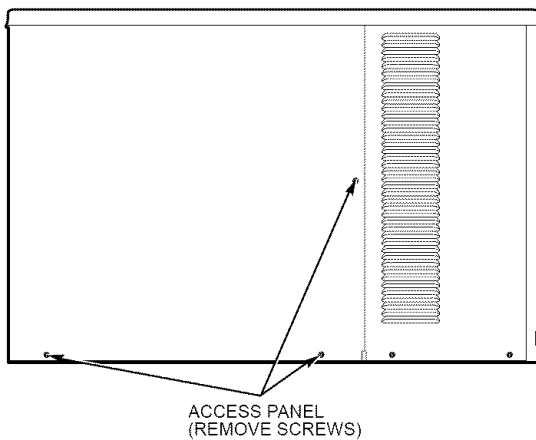

Fig. 12—Indoor Coil Access Panel

C95014

this can be overcome by applying a slight force to the base of the blower. Continue sliding blower in until hole in side plate flange aligns with the hole in the unit base. Secure using screw removed in Step 7. Reconnect indoor-fan motor leads and insert wire tie back into unit control box.

13. Cover the horizontal duct openings. Duct covers can be ordered as an accessory or field fabricated (See Fig. 20).
14. Reinstall the indoor coil and indoor blower access panels.
15. After completing unit installation, perform all safety checks and power up unit.

CONFIGURING UNITS FOR DOWNFLOW (VERTICAL) DISCHARGE-ECM UNITS (048-060)

Units 048-060 (Units with ECM Indoor Blower Motors) are shipped in a horizontal configuration. To convert a horizontal unit for downflow (vertical) discharge, perform the following steps:

⚠ WARNING

Before performing service or maintenance operations on the system, turn off main power to unit and install lockout tag or electrical shock could result.

1. Open all electrical disconnects and install lockout tag before starting any service work.
2. Remove indoor coil access panel (See Fig. 12).
3. Locate lances in unit base insulation that are placed over the perimeter of the vertical duct opening cover (See Fig. 13).
4. Using a straight edge and sharp knife, cut and remove the insulation around the perimeter of the cover. Remove the screws securing the cover to the unit base and slide out the cover. Discard the cover.
5. Remove indoor blower access panel (See Fig. 14).

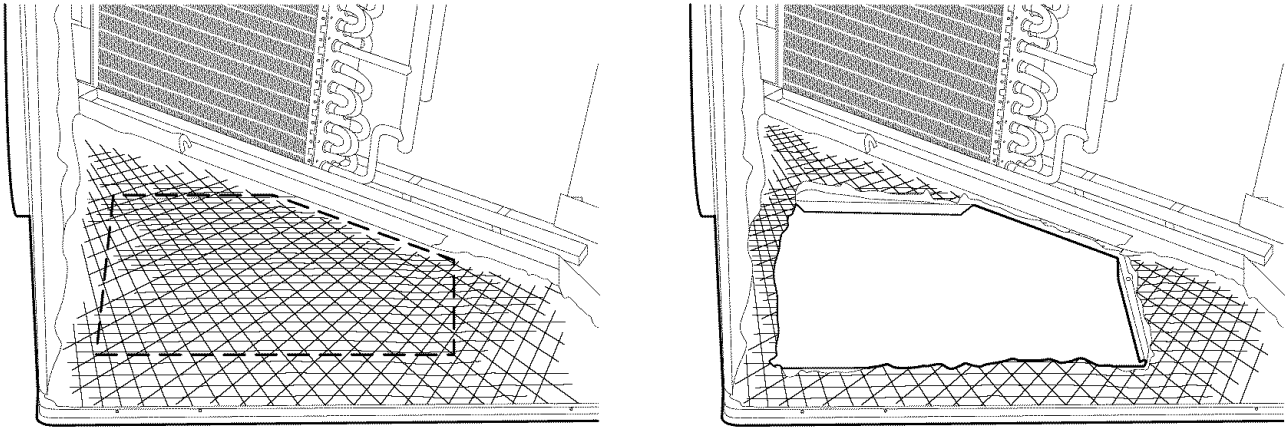

C95015

Fig. 13—Removing Insulation and Vertical Duct Cover

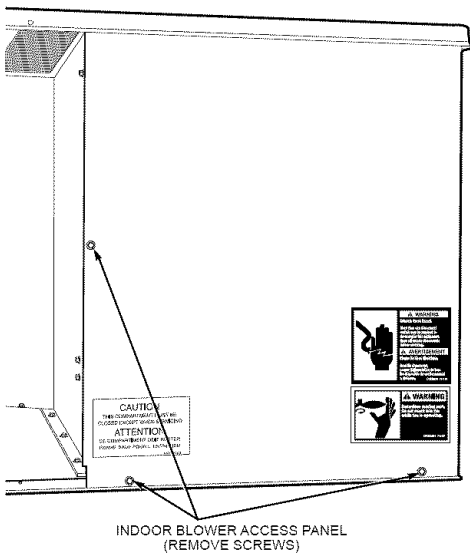

C950016

Fig. 14—Indoor Blower Access Panel

6. Disconnect the plug assemblies from the indoor-fan motor (See Fig. 15 & 17).
7. Remove screws securing indoor blower housing to blower shelf and carefully slide out blower housing. There is a filler bracket attached to the blower shelf; remove this filler bracket and retain for later use (See Fig. 16).
8. Locate lances in unit base insulation that are placed over the perimeter of the vertical discharge opening cover (See Fig. 13).
9. Using a straight edge and sharp knife, cut the insulation around the perimeter of the cover. Remove the screws securing the cover to the unit base and slide out the cover. Discard the cover. Install filler bracket removed in Step 6.
10. If unit ductwork is to be attached to vertical opening flanges on the unit base (jackstand applications only), do so at this time.
11. It is recommended that the unit base insulation around the perimeter of the vertical opening be secured to the unit base with aluminum tape to prevent the insulation from tearing or bunching up when the blower housing is installed in the vertical discharge position.
12. Remove screws securing the high-voltage raceway to duct panel. Temporarily place raceway on top of unit until blower housing is installed.
13. Orient blower housing for vertical airflow (blower motor adjacent to horizontal duct opening) and slide into vertical opening making sure the flanges on the blower side plates engage the tabs in the unit base (See Fig. 15). Resistance will be felt as the blower housing contacts the unit base insulation; this can be overcome by applying a slight force to the base of the blower. Continue sliding blower in until hole in side plate flange aligns with the hole in the unit base. Secure using screw removed in Step 6.
14. Reinstall the high-voltage raceway removed in Step 12.
15. Cover the horizontal duct openings. Duct covers can be ordered as an accessory or field fabricated (See Fig. 20).
16. Reinstall the indoor coil and indoor blower access panels.
17. After completing unit installation, perform all safety checks and power up unit.

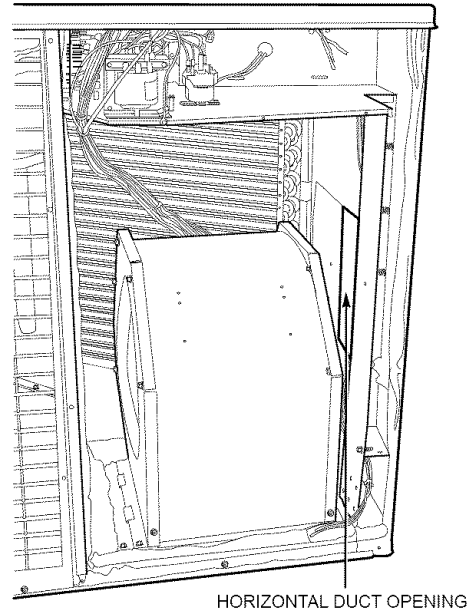
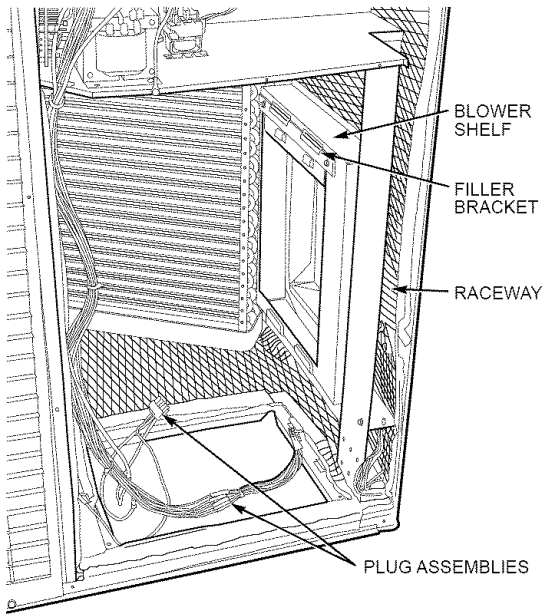

C950010

Fig. 15—Converting Blower Assembly to Vertical Airflow

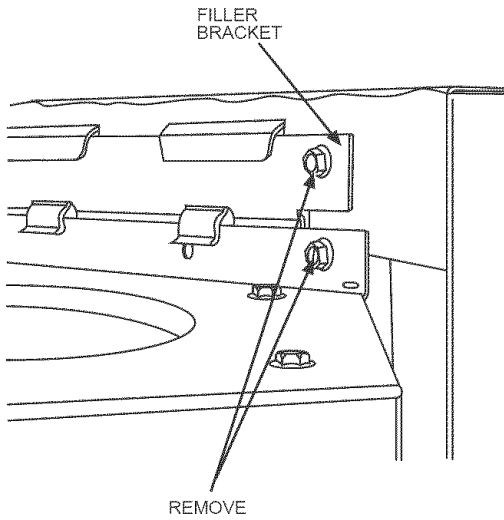

C95017

Fig. 16—Blower Shelf and Housing

Step 8—Install Electrical Connection

⚠ WARNING

The unit cabinet must have an uninterrupted, unbroken electrical ground to minimize the possibility of personal injury if an electrical fault should occur. This ground may consist of an electrical wire connected to the unit ground lug in the control compartment, or conduit approved for electrical ground when installed in accordance with NEC (National Electrical Code) ANSI/NFPA (latest edition) and local electrical codes. In Canada, follow Canadian Electrical Code CSA (Canadian Standards Association) C22.1 and local electrical codes. Failure to adhere to this warning could result in personal injury or death.

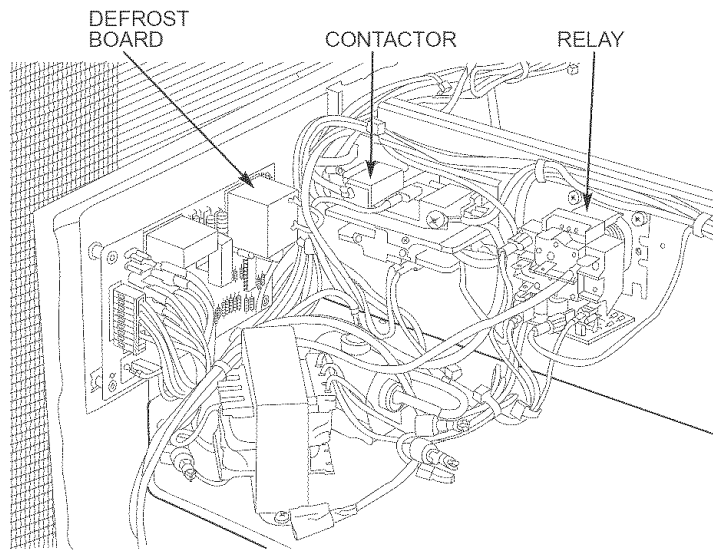

Fig. 17—Control Box Detail View

C95017

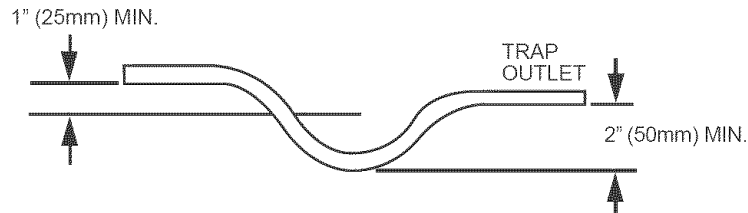

Fig. 18—Condensate Trap

C99013

Table 1—Physical Data—Unit 50HX

UNIT SIZE	024	030	036	042	048	060
NOMINAL CAPACITY (ton)	2	2-1/2	3	3-1/2	4	5
OPERATING WEIGHT (lb.) Without Base Rails With Optional Rails	309 296	340 327	368 355	368 355	411 398	425 412
COMPRESSOR	Scroll					
REFRIGERANT (R-22) Quantity (lb.)	5.4	5.6	8.6	6.8	7.9	8.1
REFRIGERANT METERING DEVICE	Acutrol™ System					
OUTDOOR COIL Rows...Fins/in. Face Area (sq. ft.)	2...17 7.0	2...17 7.0	2...17 8.7	2...17 8.7	2...17 8.7	2...17 8.7
OUTDOOR FAN Nominal Cfm Diameter (in.) Motor Hp (Rpm)	2200 20 1/4 (1100)	2200 20 1/4 (1100)	2200 20 1/4 (1100)	2400 20 1/4 (1100)	2400 20 1/3 (1100)	2400 20 1/3 (1050)
INDOOR COIL Rows...Fins/in. Face Area (sq. ft.)	3...15 3.6	3...15 3.6	4...15 4.5	4...15 4.5	4...15 4.5	4...15 4.5
INDOOR BLOWER Motor Type Speeds Nominal Airflow (Cfm) Size (in.) Motor Hp (RPM)	PSC 3 800 10x9 1/4 (1075)	PSC 3 1000 10x9 1/4 (1075)	PSC 3 1300 10x9 1/2 (1100)	PSC 3 1400 10x9 1/2 (1100)	ECM Variable 1550 10x10 1.0 (Variable)	ECM Variable 1800 10x10 1.0 (Variable)
RETURN-AIR FILTERS (in.) Throwaway	24x24x1	24x24x1	24x30x1	24x30x1	24x30x1	24x30x1

ECM—Electronic Computed Motor.

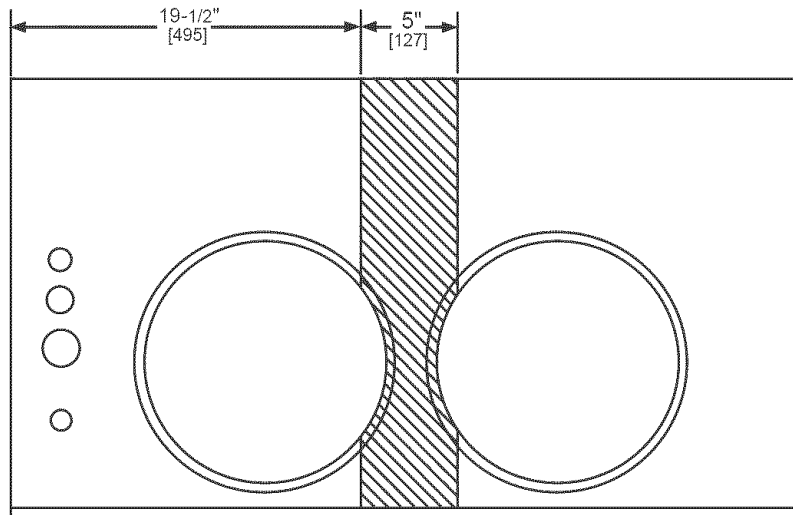

NOTES:

1. Do not drill more than 1/2-in into shaded area.
2. Dimensions in [] are in mm.

C95012

Fig. 19—Area Not To Be Drilled

CAUTION

Failure to follow these precautions could result in damage to the unit being installed:

1. Make all electrical connections in accordance with NEC ANSI/NFPA (latest edition) and local electrical codes governing such wiring. In Canada, all electrical connections must be in accordance with CSA standard C22.1 Canadian Electrical Code Part 1 and applicable local codes. Refer to unit wiring diagram.
2. Use only *copper* conductor for connections between field-supplied electrical disconnect switch and unit. **DO NOT USE ALUMINUM WIRE.**
3. Be sure that high-voltage power to unit is within operating voltage range indicated on unit rating plate.
4. Do not damage internal components when drilling through any panel to mount electrical hardware, conduit, etc. On 3-phase units, ensure phases are balanced within 2 percent. Consult local power company for correction of improper voltage and/or phase imbalance.

HIGH-VOLTAGE & CONTROL-VOLTAGE CONNECTIONS

The unit must have a separate electrical service with a field-supplied, waterproof, disconnect switch mounted at, or within sight from, the unit. Refer to the unit rating plate for maximum fuse/circuit breaker size and minimum circuit amps (ampacity) for wire sizing. See Table 3 for electrical data.

The field-supplied disconnect switch box may be mounted on the unit over the high-voltage inlet hole when the standard power and low-voltage entry points are used. See Fig. 21 for acceptable location.

See unit wiring label and Fig. 23, 24 & 26-27 for reference when making high voltage connections. Proceed as follows to complete the high-voltage connections to the unit.

If the unit has an electric heater, a second disconnect may be required. Consult the Installation Instructions provided with the accessory heater for electrical service connections.

1. **ROUTING POWER LEADS INTO UNIT**-Use only copper wire between disconnect and unit. The high-voltage leads should be in a conduit until they enter the duct panel; conduit termination at the duct panel must be watertight. Run the

high-voltage leads through the knockout on the duct panel (see Fig. 21 for location and size). When the leads are inside the unit, run leads up the high-voltage raceway to the line wiring splice box (Fig. 22). For single-phase units, connect leads to the black and yellow wires (see Fig. 24 & 26-27).

2. **CONNECTING GROUND LEAD TO WIRE-BINDING SCREW** - Refer to Fig. 22. Connect the ground lead to the chassis using the wire-binding screw in the wiring splice box.
3. **ROUTING CONTROL POWER WIRES - STD NON-ECM UNITS (24 v)** -Form a drip-loop with the thermostat leads before routing them into the unit. Route the thermostat leads through grommetted hole provided in unit (see Fig. 21) into unit control power splice box. Connect thermostat leads to unit control power leads as shown in Fig. 23.
4. **ROUTING CONTROL POWER WIRES - ECM UNITS (24 v)** - Remove knockout in the duct panel (see Fig. 21). Remove the rubber grommet from the installer's packet (included with unit) and install it in the knockout opening. Route thermostat wires through grommet providing a drip loop at the panel. Connect low-voltage leads to the thermostat as shown in Fig. 23.

The Easy Select interface board is located in the return-air section and is attached to the duct panel. The Easy Select interface board is factory wired to the motor and factory default selections are preset.

5. The unit transformer supplies 24-v power for complete system including accessory electrical heater. Transformer is factory wired for 230-v operation. If supply voltage is 208 v, rewire transformer primary as described in the Special Procedures for 208-v Operation section.

NOTE: Do not use any type of power-stealing thermostat. Unit control problems may result.

Use no. 18 American Wire Gage (AWG) color-coded, insulated (35 C minimum) wires to make the control voltage connections between the thermostat and the unit. If the thermostat is located more than 100 ft. from the unit (as measured along the control voltage wires), use no. 16 AWG color-coded, insulated (35 C minimum) wires.

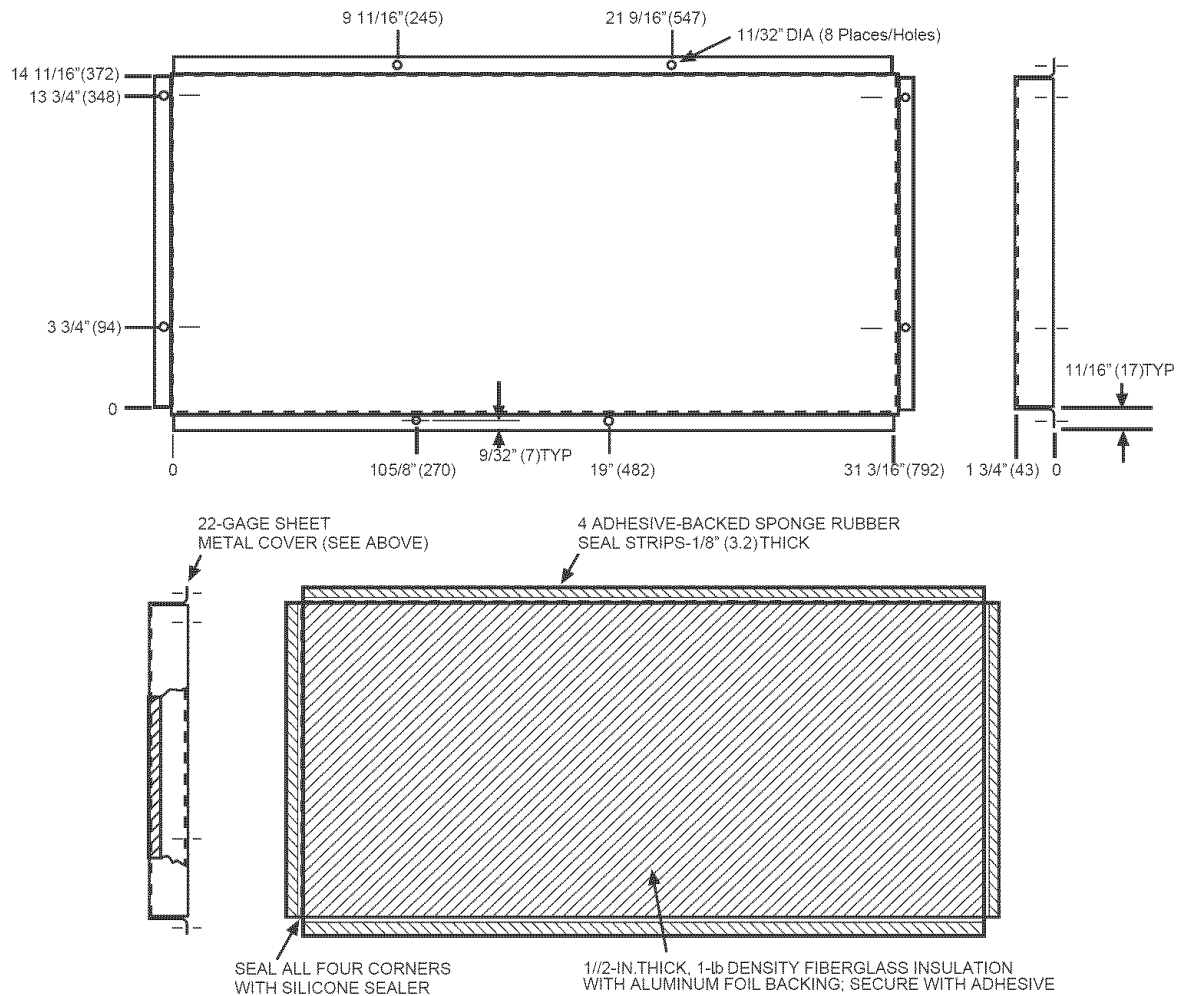

NOTES:

1. An accessory duct cover is available as an alternative to field fabrication.
2. Construct duct cover out of 22-gage sheet metal.
3. Dimensions in () are in millimeters.

C95019

Fig. 20—Field-Fabricated Duct Cover

Table 2—Minimum Airflow for Safe Electric Heater Operation (Cfm)

SIZE					
024	030	036	042	048	060
700	875	1225	1225	1400	1750

SPECIAL PROCEDURES FOR 208-V OPERATION

⚠ WARNING

Make sure that the power supply to the unit is switched OFF and lockout tag installed before making any wiring changes. Electrical shock can cause serious injury or death.

1. Disconnect the orange transformer-primary lead from the contactor. See unit wiring label
2. Remove the wire nut from the terminal on the end of the red transformer-primary lead.
3. Save the wire nut.
4. Connect the red lead to the contactor terminal from which the orange lead was disconnected.
5. Using the wire nut removed from the red lead, insulate the loose terminal on the orange lead.

6. Wrap the wire nut with electrical tape so that the metal terminal cannot be seen.

NOTE: Indoor blower motor speeds may need to be changed for 208-v operation. Refer to *Indoor Airflow and Airflow Adjustment* Section.

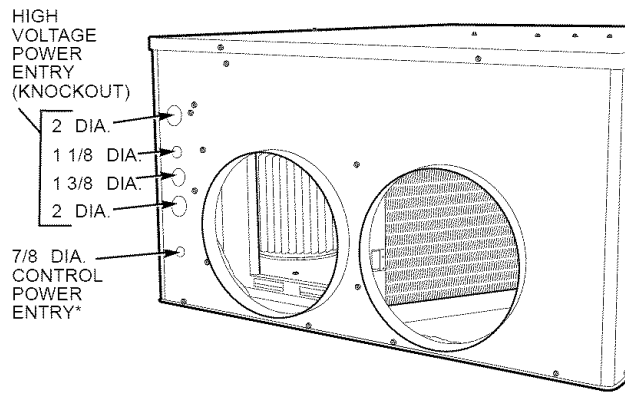

*Knockout on rectangular-duct panel units; entry hole on round-duct panel units.

NOTE: For rectangular duct knockout sizes, see Fig. 2-9.

C95036

Fig. 21—Typical Duct Panel Knockouts

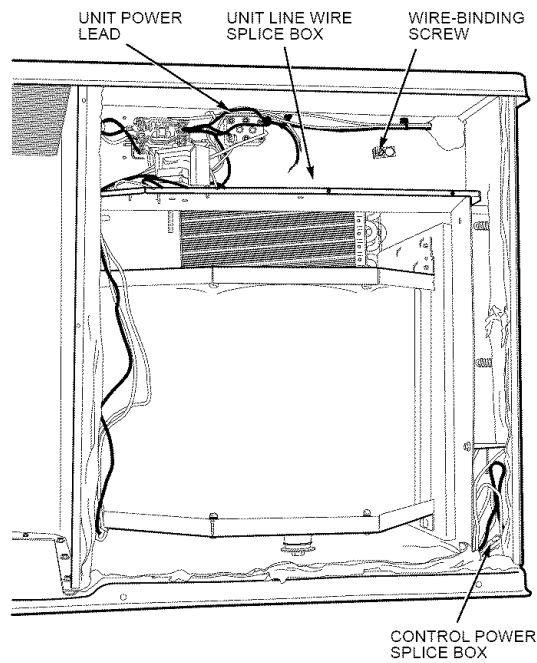

Fig. 22—Wiring Splice Boxes

C95022



Table 3—Electrical Data—50HX

UNIT 50HX SIZE (-SERIES, IF USED)	V-PH (60 HZ)	VOLTAGE RANGE		COMPRESSOR		OFM	IFM	ELECTRIC HEAT		SINGLE-POINT POWER SUPPLY			DUAL-POINT POWER SUPPLY (INCLUDING UNIT ONLY)					
		Min	Max	RLA	LRA	FLA	FLA	kW	FLA	Single- Point Wiring MCA	Single- Point Max Fuse or Ckt Bkr	Single- Point MOCP	Heater Only Dual- Point Wiring MCA	Heater Only Dual- Point Max Fuse or Ckt Bkr	Heater Only Dual- Point MOCP	Unit Only Dual- Point MCA	Unit Only Dual- Point Max Fuse or Ckt Bkr	Unit Only Dual Point MOCP
024-311	208/230-1	187	253	11.2	56.0	1.4	2.0	3.75/5.00 5.60/7.50 7.50/10.0	18.1/20.8 27.1/31.3 36.1/41.7	40.3/43.4 51.0/56.5 62.5/69.5	45/45 60/60 —	— — 70/80	22.5/26.0 33.7/39.1 45.1/50.8	25/30 35/40 50/60	— — —	17.4	25/25	—
024-321	208/230-1	187	253	12.1	54.0	1.4	2.0	3.75/5.00 5.60/7.50 7.50/10.0	18.1/20.8 27.1/31.3 36.1/41.7	41.4/44.5 52.2/57.7 63.7/70.7	45/45 60/60 —	— — 70/80	22.5/26.0 33.7/39.1 45.1/50.8	25/30 35/40 50/60	— — —	18.5	25/25	—
030	208/230-1	187	253	15.0	73.0	1.4	2.6	3.75/5.00 5.60/7.50 7.50/10.0 11.30/15.0	18.1/20.8 27.1/31.3 36.1/41.7 54.1/62.0	45.3/48.8 56.6/61.8 67.9/74.8 90.4/100.3	50/50 60/- — —	— -70 70/80 100/100	22.5/26.0 33.7/39.1 45.1/50.1 67.9/78.1	25/30 35/40 50/60 —	— — — 70/80	22.8	30/30	—
036	208/230-1	187	253	16.0	88.0	1.2	2.6	3.75/5.00 5.60/7.50 7.50/10.0 11.30/15.0	18.1/20.8 27.1/31.3 36.1/41.7 54.1/62.0	48.3/51.7 56.6/61.8 67.9/74.8 90.4/100.3	60/60 60/- — —	— -70 80/80 100/110	22.5/26.0 33.7/39.1 45.1/50.1 67.9/78.1	25/30 35/40 50/60 —	— — — 70/80	23.8	35/35	—
042	208/230-1	187	253	20.0	104.0	1.4	3.1	3.75/5.00 5.60/7.50 7.50/10.0 11.30/15.0 15.0/20.0	18.1/20.8 27.1/31.3 36.1/41.7 54.1/62.0 72.2/83.3	52.1/55.5 63.3/68.6 74.6/81.6 97.1/107.0 119.8/133.7	60/60 — — — —	— 70/80 80/90 100/110 125/150	22.5/26.0 33.7/39.1 45.1/50.8 67.9/78.1 90.1/104.2	25/30 35/40 50/60 — 100/110	— — — 70/80 100/110	29.5	45/45	—
048-301	208/230-1	187	253	26.4	129.0	2.1	7.2	3.75/5.00 5.60/7.50 7.50/10.0 11.30/15.0 15.0/20.0	18.1/20.8 27.1/31.3 36.1/41.7 54.1/62.0 72.2/83.3	65.2/68.3 75.9/81.4 87.4/94.4 110.2/120.4 131.8/145.9	— — — — —	70/70 80/90 90/100 125/125 150/150	22.5/26.0 33.7/39.1 45.1/50.8 67.9/78.1 90.1/104.2	25/30 35/40 50/60 — 100/110	— — — 70/80 100/110	42.3	50/50	—
048-311	208/230-1	187	253	20.8	109.0	2.1	7.2	3.75/5.00 5.60/7.50 7.50/10.0 11.30/15.0 15.0/20.0	18.1/20.8 27.1/31.3 36.1/41.7 54.1/62.0 72.2/83.3	58.2/61.3 68.9/74.4 80.4/87.4 103.2/113.4 124.8/138.9	60/- — — — —	-70 70/80 90/90 110/125 125/150	22.5/26.0 33.7/39.1 45.1/50.8 67.9/78.1 90.1/104.2	25/30 35/40 50/60 — 100/110	— — — 70/80 100/110	35.3	45/45	—
060	208/230-1	187	253	32.1	169.0	2.1	7.2	3.75/5.00 5.60/7.50 7.50/10.0 11.30/15.0 15.0/20.0	18.1/20.8 27.1/31.3 36.1/41.7 54.1/62.0 72.2/83.3	72.0/75.5 83.3/88.5 94.6/101.5 117.1/126.9 139.6/153.5	— — — — —	90/100 100/100 100/110 125/150 150/175	22.5/26.0 33.7/39.1 45.1/50.8 67.9/78.1 90.1/104.2	25/30 35/40 50/60 — 100/110	— — — 70/80 100/110	48.7	—	80/80

(See legend following Electrical Data chart)

- LEGEND
- FLA — Full Load Amps
 - LRA — Locked Rotor Amps
 - MCA — Minimum Circuit Amps
 - MOCP — Maximum Overcurrent Protection
 - RLA — Rated Load Amps
 - CKT BKR — Circuit Breaker



NOTES:

1. In compliance with NEC (National Electrical Code) requirements for multimotor and combination load equipment (refer to NEC Articles 430 and 440), the overcurrent protective device for the unit shall be Power Supply fuse. Canadian units may be fuse or circuit breaker.
2. Minimum wire size is based on 60 C copper wire. If other than 60 C wire is used, or if length exceeds wire length in table, determine size from NEC.
3. Unbalanced 3-Phase Supply Voltage
Never operate a motor where a phase imbalance in supply voltage is greater than 2%. Use the following formula to determine the percentage of voltage imbalance.

% Voltage imbalance

$$= 100 \times \frac{\text{max voltage deviation from average voltage}}{\text{average voltage}}$$

EXAMPLE: Supply voltage is 460-3-60.

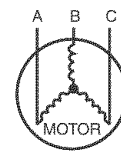

- AB = 452 v
- BC = 464 v
- AC = 455 v

$$\begin{aligned} \text{Average Voltage} &= \frac{452 + 464 + 455}{3} \\ &= \frac{1371}{3} \\ &= 457 \end{aligned}$$

Determine maximum deviation from average voltage.

- (AB) 457 - 452 = 5 v
- (BC) 464 - 457 = 7 v
- (AC) 457 - 455 = 2 v

Maximum deviation is 7 v.

Determine percent of voltage imbalance.

$$\begin{aligned} \% \text{ Voltage Imbalance} &= 100 \times \frac{7}{457} \\ &= 1.53\% \end{aligned}$$

This amount of phase imbalance is satisfactory as it is below the maximum allowable 2%.

IMPORTANT: If the supply voltage phase imbalance is more than 2%, contact your local electric utility company immediately.

C99024

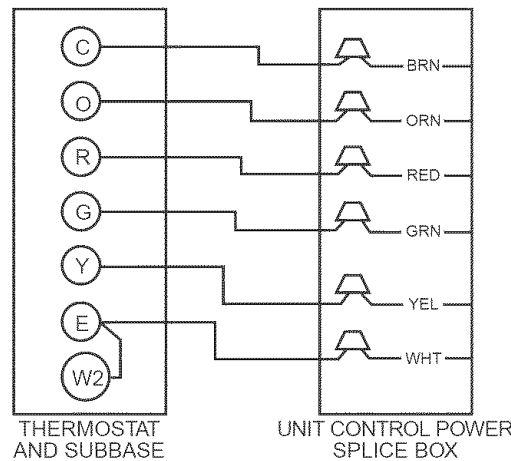
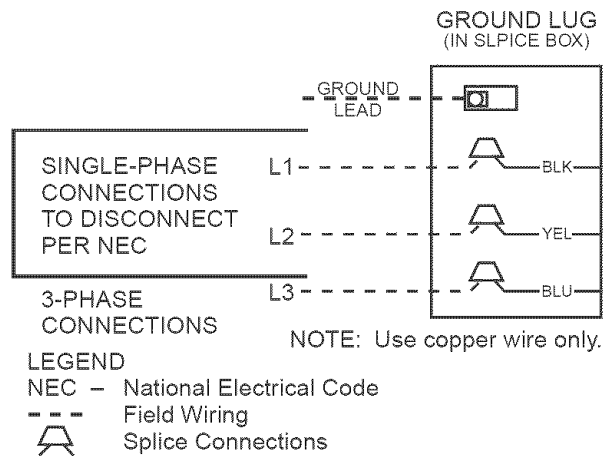

Fig. 23—Control-Voltage Connections

C99056



C99057

Fig. 24—High-Voltage Connections

PRE-START-UP

⚠ WARNING

Failure to observe the following warnings could result in serious personal injury:

1. Follow recognized safety practices and wear protective goggles when checking or servicing refrigerant system.
2. Do not operate compressor or provide any electric power to unit unless compressor terminal cover is in place and secured.
3. Do not remove compressor terminal cover until all electrical sources are disconnected.
4. Relieve and recover all refrigerant from system before touching or disturbing anything inside terminal box if refrigerant leak is suspected around compressor terminals.
5. Never attempt to repair soldered connection while refrigerant system is under pressure.
6. Do not use torch to remove any component. System contains oil and refrigerant under pressure. To remove a component, wear protective goggles and proceed as follows:
 - a. Shut off electrical power to unit.
 - b. Relieve and reclaim all refrigerant from system using both high- and low-pressure ports.
 - c. Cut component connecting tubing with tubing cutter and remove component from unit.
 - d. Carefully unsweat remaining tubing stubs when necessary. Oil can ignite when exposed to torch flame.

Proceed as follows to inspect and prepare the unit for initial startup:

1. Remove access panel.
2. Read and follow instructions on all WARNING, CAUTION, and INFORMATION labels attached to, or shipped with, unit.
3. Make the following inspections:
 - a. Inspect for shipping and handling damages such as broken lines, loose parts, disconnected wires, etc.
 - b. Inspect for oil at all refrigerant tubing connections and on unit base. Detecting oil generally indicates a refrigerant leak. Leak test all refrigerant tubing connections using electronic leak detector, halide torch, or liquid-soap solution. If a refrigerant leak is detected, see Check for Refrigerant Leaks section.
 - c. Inspect all field- and factory-wiring connections. Be sure that connections are completed and tight.

- d. Ensure electrical wiring does not contact refrigerant tubes or sharp metal edges.
 - e. Inspect coil fins. If damaged during shipping and handling, carefully straighten fins with a fin comb.
4. Verify the following conditions
- a. Make sure that outdoor-fan blade is correctly positioned in fan orifice. Leading edge of outdoor-fan blade should be 2 in. back from inlet grille or 1/2-in. maximum from the fan deck.
 - b. Make sure that air filter(s) is in place.
 - c. Make sure that condensate drain trap is filled with water to ensure proper drainage.
 - d. Make sure that all tools and miscellaneous loose parts have been removed.
5. Compressors are internally spring mounted. Do not loosen or remove compressor hold-down bolts.
6. Each unit (system) has 2 Schrader-type ports, one low-side fitting located on the suction line, and one high-side fitting located on the compressor discharge line. Be sure that caps covering these Schrader fittings are tight.

START-UP

CHECK FOR REFRIGERANT LEAKS

Proceed as follows to locate and repair a refrigerant leak and to charge the unit:

1. Locate leak and make sure that refrigerant system pressure has been relieved and reclaimed from both high- and low-pressure ports.
2. Repair leak following accepted practices. NOTE: Install a filter drier whenever the system has been opened for repair.
3. Add a small charge of R-22 refrigerant vapor to system and leak-test unit.
4. Recover refrigerant from refrigerant system and evacuate to 500 microns if no additional leaks are not found.
5. Charge unit with R-22 refrigerant, using a volumetric-charging cylinder or accurate scale. Refer to unit rating plate for required charge. Be sure to add extra refrigerant to compensate for internal volume of filter drier.

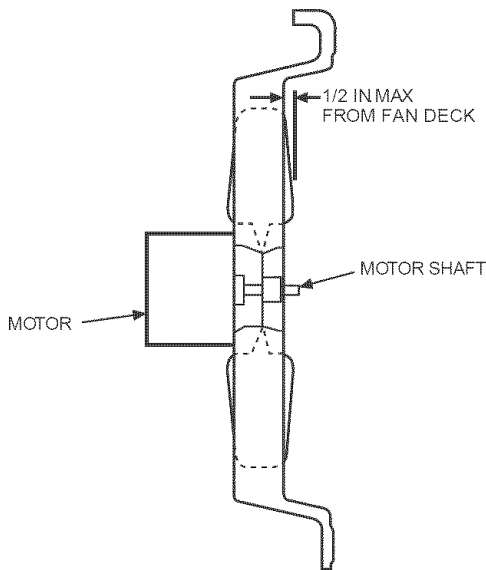

C95027

Fig. 25—Fan Blade Clearance

START UP AND MAKE ADJUSTMENTS

⚠ CAUTION

Complete the required procedures given in the Pre-Start-Up section before starting the unit. Do not jumper any safety devices when operating the unit. Do not operate the compressor when the outdoor temperature is below 40°F (unless accessory low-ambient kit is installed). Do not rapid-cycle the compressor. Allow 5 minutes between “on” cycles to prevent compressor damage.

CHECKING COOLING CONTROL OPERATION

Start and check the unit for proper cooling control operation as follows:

1. Place room thermostat SYSTEM switch in OFF position. Observe that blower motor starts when FAN switch is placed in ON position and shuts down when FAN switch is placed in AUTO position.
2. Place SYSTEM switch in COOL position and FAN switch in AUTO position. Set cooling control below room temperature. Observe that compressor, outdoor fan, and indoor blower motors start. Observe that compressor and outdoor fan shut down when control setting is satisfied and that indoor blower shuts down after fan time delay expires.
3. When using an auto-changeover room thermostat, place both SYSTEM and FAN switches in AUTO positions. Observe that unit operates in heating mode when temperature control is set to “call for heating” (above room temperature) and operates in cooling mode when temperature control is set to “call for cooling” (below room temperature).

CHECKING HEATING CONTROL OPERATION

Start and check the unit for proper cooling control operation as follows:

1. Place room thermostat SYSTEM switch in OFF position. Observe that blower motor starts when FAN switch is placed in ON position and shuts down when FAN switch is placed in AUTO position.
2. Place SYSTEM switch in HEAT position and FAN switch in AUTO position. Set cooling control above room temperature. Observe that compressor, outdoor fan, and indoor blower motors start. Observe that compressor and outdoor fan shut

down when control setting is satisfied and that indoor blower shuts down after fan time delay expires.

3. When using an auto-changeover room thermostat, place both SYSTEM and FAN switches in AUTO positions. Observe that unit operates in heating mode when temperature control is set to “call for heating” (above room temperature).
4. If system is equipped with supplemental or emergency heat (resistance heaters), observe that when thermostat is placed in EMERGENCY HEAT mode and temperature control is set above room temperature that heaters and indoor blower come on. Observe that heaters shut off when control setting is satisfied and that the indoor blower shuts off after fan time delay expires.

CHECKING AND ADJUSTING REFRIGERANT CHARGE

The refrigerant system is fully charged with R-22 refrigerant, tested, and factory-sealed.

NOTE: Adjustment of the refrigerant charge is not required unless the unit is suspected of not having the proper R-22 charge.

A superheat charging chart is attached to the outside of the compressor access panel. The chart includes the required suction line temperature at given suction line pressures and outdoor ambient temperatures (See Table 13A-H and Fig. 30).

An accurate superheat, thermocouple- or thermistor-type thermometer, a sling psychrometer, and a gauge manifold are required when using the superheat charging method for evaluating the unit charge. *Do not use mercury or small dial-type thermometers because they are not adequate for this type of measurement.*

NOTE: Allow system to operate in the cooling mode for a minimum of 10 minutes before checking or adjusting refrigerant charge.

⚠ CAUTION

When evaluating the refrigerant charge, an indicated adjustment to the specified factory charge must always be very minimal. If a substantial adjustment is indicated, an abnormal condition exists somewhere in the cooling system, such as insufficient airflow across either coil or both coils. Failure to adjust charge properly or correct the abnormal conditions will cause damage to the unit.

Proceed as follows:

1. Remove caps from low- and high-pressure service fittings.
2. Using hoses with valve core depressors, attach low- and high-pressure gauge hoses to low- and high-pressure service fittings, respectively.
3. Start unit in Cooling mode and let unit run until system pressures stabilize.
4. Measure and record the following:
 - a. Outdoor ambient-air temperature (°F db).
 - b. Indoor coil inlet-air temperature (°F wb).
 - c. Suction-tube temperature (°F) at low-side service fitting.
 - d. Suction (low-side) pressure (psig).
5. Using “Superheat Charging Charts” compare outdoor-air temperature (°F db) with the Indoor coil air inlet temperature (°F wb) to determine desired system operating superheat temperature. See Table 13A-H and Fig. 30.
6. Using “Required Suction-Tube Temperature (F)” table, compare desired superheat temperature with suction (low-side) operating pressure (psig) to determine proper suction-tube temperature. See Fig. 30.

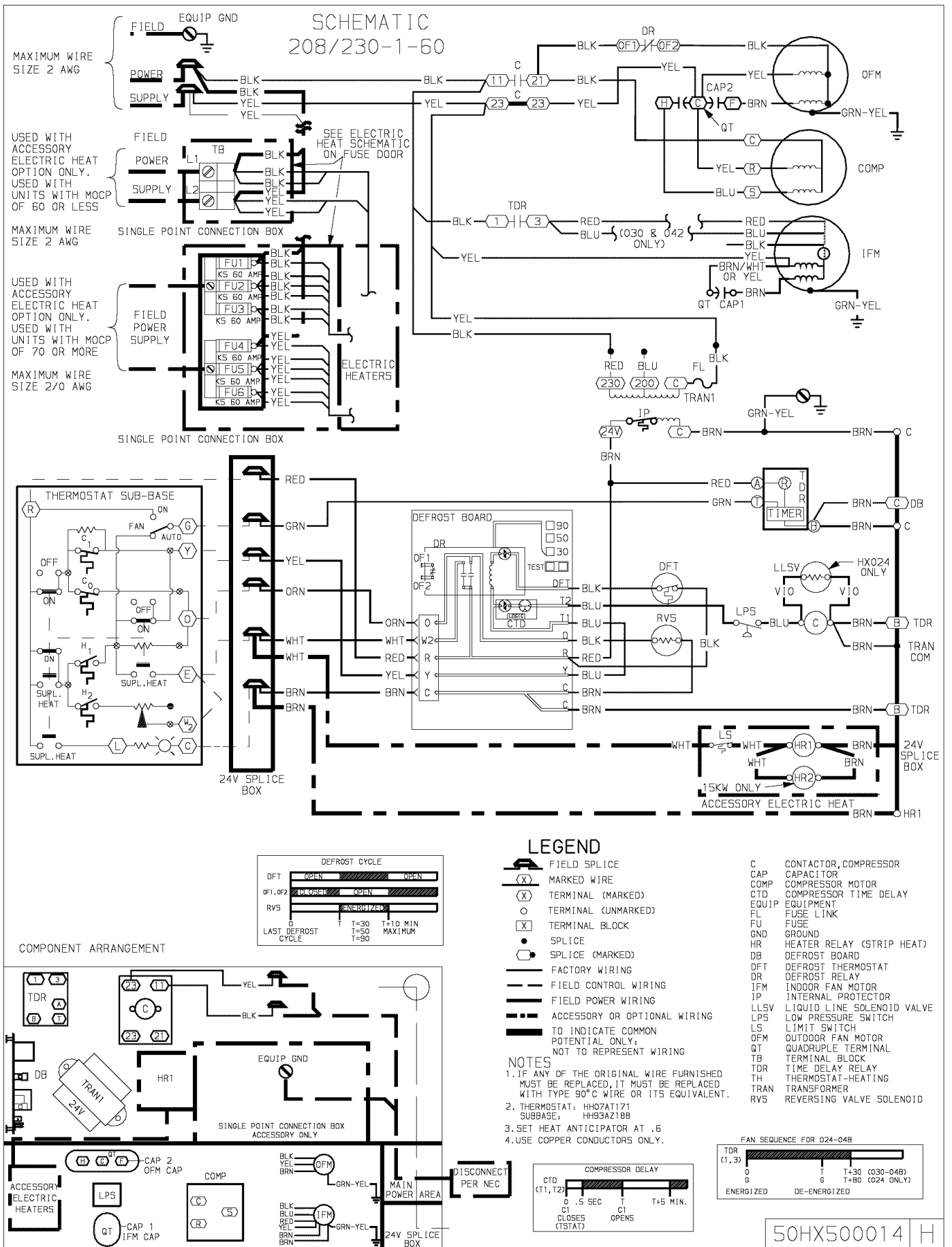

Fig. 26—Wiring Diagram—024 to 042 (208/230-60-1)

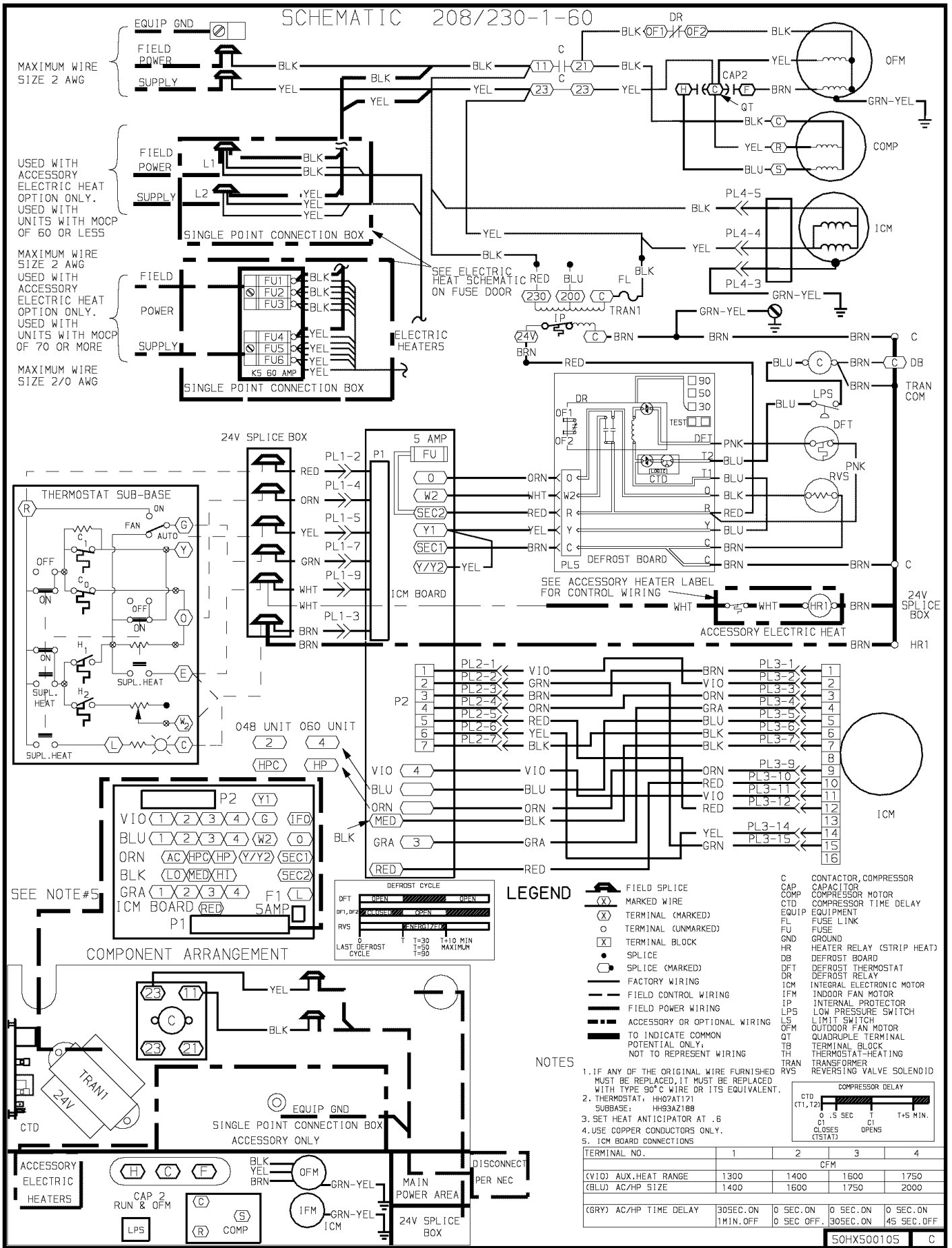

Fig. 27—Wiring Diagram—048 to 060 (208/230-60-1 with ECM Indoor)

TRANSFORMER CONTAINS A MANUAL
RESET OVERCURRENT PROTECTOR

IT WILL NOT AUTOMATICALLY RESET

DISCONNECT POWER AND INSTALL
LOCKOUT TAG PRIOR TO SERVICING

THIS COMPARTMENT MUST BE CLOSED
EXCEPT WHEN SERVICING

C95025

Fig. 28—Transformer Label

7. Compare actual suction-tube temperature with proper suction-tube temperature. Using a tolerance of $\pm 3^{\circ}$ F, add refrigerant if actual temperature is more than 3° F higher than proper suction-tube temperature, or remove refrigerant if actual temperature is more than 3° F lower than required suction-tube temperature.

NOTE: If the problem causing the inaccurate readings is a refrigerant leak, refer to Check for Refrigerant Leaks section.

INDOOR AIRFLOW AND AIRFLOW ADJUSTMENTS

NOTE: For cooling operation, the recommended airflow is 350 to 450 cfm for each 12,000 Btu/h of rated cooling capacity.

Table 8 shows cooling airflows at various external static pressures. Table 9 shows Fan Only and Cooling modes for ECM units (048-060). Refer to these tables to determine the airflow for the system being installed.

NOTE: Be sure that all supply- and return-air grilles are open, free from obstructions, and adjusted properly.

⚠ WARNING

Disconnect electrical power to the unit and install lockout tag before changing blower speed. Electrical shock can cause serious injury or death.

Airflow can be changed by changing the lead connections of the blower motor.

Unit 50HX three-speed motors (024–042) are factory wired for low speed operation.

FOR 208/230V-PSC BLOWER MOTOR

For color coding on the 208/230V motor leads, see Table 4.

Table 4—Color Coding for 208/230–v Motor Leads

3-SPEED
black = high speed
blue = medium speed
red = low speed

To change the speed of the indoor fan motor (IFM), remove the fan motor speed leg lead from the indoor fan relay (IFR) and replace with lead for desired blower motor speed. *Insulate the removed lead to avoid contact with chassis parts.*

FOR 208/230V-ECM BLOWER MOTOR

To configure the 50HX 048-60 unit, move the 5 Easy Select board wires to the terminals which control the airflow. Refer to the Easy Select interface board (Fig. 29) located next to the terminal. Perform the following steps for basic system configuration.

1. AUX HEAT RANGE (VIO) **NOTE:** If no heater is installed, this step can be omitted. The airflow for electric heat is selected with the AUX HEAT RANGE terminals. Refer to Table 2 and the installation instructions for electric heaters for

minimum airflow required for safe heater operation. Refer to table below for the available airflows. Each select pin is configured for a certain airflow. The airflow will be supplied in the Heating mode on air conditioners when electric heat is the primary heating source. The preset factory default selection is the highest airflow.

2. AC/HP SIZE (BLU) - The preset factory default selection for AC/HP SIZE (air conditioner/heat pump) is set to 400 cfm/ton. The selection pins are configured for 350 cfm/ton and 400 cfm/ton.
3. TYPE (ORN) - The TYPE is a preset factory default selection. The preset factory default setting is AC for the 50HX units. Default setting should not be altered.
4. AC/HP CFM ADJUST (BLK) - The preset factory default selection is MED. Selections HI and LO will adjust the airflow supplied for all operational modes (see table below). The selection options allow installer to adjust airflow to meet such individual needs as noise and static compensation, etc.
5. AC/HP TIME DELAY (GRY) - Four motor operation delay options are provided to customize system operation. See listing below:

Unit Controls— All compressors have the following internal-protection controls.

1. High-Pressure Relief Valve - This valve opens when the pressure differential between the low and high side becomes excessive.
2. Compressor Overload - This overload interrupts power to the compressor when either the current or internal temperature become excessive, and automatically resets when the internal temperature drops to a safe level.
This overload may require up to 60 minutes (or longer) to reset; therefore, if the internal overload is suspected of being open, disconnect the electrical power to the unit and check the circuit through the overload with an ohmmeter or continuity tester.

COOLING SEQUENCE OF OPERATION

PSC Blower Motor Units (024–042)

NOTE: With the FAN switch in the ON position, 24-v is supplied to the IFR through the G terminal on the thermostat. This voltage energizes the coil of the contactor, closing the normally-open set of contacts which provide continuous power to the indoor (evaporator) fan motor (IFM). Moving the FAN switch back to the AUTO. position, providing there is not a call for cooling, deenergizes the IFR, opens the IFR contacts, and deenergizes the IFM. The FAN switch in AUTO. position cycles upon a call for cooling.

On a call for cooling, 24 v is supplied to the compressor contactor (C) and IFR simultaneously through the Y and G terminals of the thermostat, respectively. On units with a compressor time delay relay, there is a built-in, 5-minute (± 45 seconds) delay between

Table 5—Terminal Configuration

TERMINAL	1	2	3	4
Available Airflow (CFM)	1365	1470	1680	1840

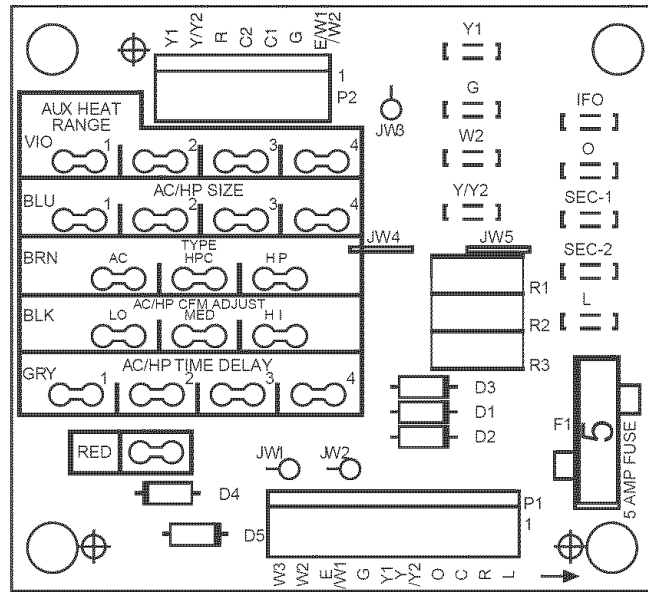

LEGEND

- IFO** — Indoor Fan On
- JW** — Jumper Wire

C95024

Fig. 29—Easy Select Interface Board for Units 048-060 with ECM Blower Motor

Table 6—CFM Adjust (Percent of CFM)

MODE	FAN ONLY	COOLING	HEATING
LO-Adjust	-15	-10	-10
HI-Adjust	15	10	10

Table 7—ECM Board Pin Selection

OPTION	DESCRIPTION
30-Sec On/60-Sec Off Delay Profile (Terminal 1)	Used when it is desirable to allow system coils time to heat up or cool down prior to airflow
No Delay Option (Terminal 2)	Used for servicing or when other components are used to perform the delay function
30-Sec Off Delay (Terminal 3)	Preset factory setting for 50HX units
45-Sec Off Delay (Terminal 4)	Enhances system efficiency

compressor starts. Energizing the contactor closes the normally-open set of contacts supplying power to both the compressor and outdoor (condenser) fan motor (OFM). Energizing the IFR closes the normally-open set of contacts providing power to the IFM. On the loss of the call for cooling, 24 v is removed from both the Y and G terminals of the thermostat (providing the FAN switch is in the AUTO. position), deenergizing both the contactor and IFR and opening both the contacts supplying power to compressor/OFM and IFM.

ECM Blower Motor Units (048-060)

Indoor Fan - With the fan switch in the ON position, 24-v is supplied to the ECM motor through the "G" terminal on the

thermostat. This voltage provides continuous power to the indoor (evaporator) fan motor (IFM). If the fan switch is moved back to the AUTO position and there is not a call for heating or cooling, 24-v is removed from the "G" terminal and the indoor fan remains energized for the delay timing. When the fan switch is in AUTO, the fan cycles with either the call for heating or cooling.

Cooling- On a call for cooling, 24 v is supplied to the compressor contactor (C) and IFM simultaneously through the "Y" and "G" terminals of the thermostat. Energizing the contactor closes the normally open set of contacts supplying power to both the compressor and outdoor (condenser) fan motor (OFM). On the loss of the call for cooling, 24 v is removed from the "Y" and "G"

terminals of the thermostat, deenergizing the compressor and OFM. The indoor fan remains energized for the delay timing.

NOTE: Once the compressor has started and then stopped, it cannot be restarted again until 5 minutes have elapsed.

HEATING SEQUENCE OF OPERATION

PSC Blower Motor Units (024-042)

Heat Pump Heating - On a call for heat, thermostat makes circuits R-Y and R-G. When compressor time delay (5 +/- 2 minutes) is completed, a circuit is made to C, starting COMP and OFM. Circuit R-G also energizes IFR and starts IFM after 1-sec. delay.

Should room temperature continue to fall, circuit R-W is made through second-stage thermostat bulb. If optional electric heat package is used, a relay is energized, bringing on first bank of supplemental electric heat. When thermostat is satisfied, contacts open, deenergizing contactor and relay; motors and heaters deenergize. The IFM may be controlled by a time-delay relay that will extend IFM operation for a matter of sec.

Defrost Mode - Defrost board (DB) is a time and temperature control, which includes a field-selectable time period between checks for defrost (30, 50 or 90 minutes). Electronic timer and defrost cycle start only when contactor is energized and defrost thermostat (DFT) is closed.

Defrost mode is identical to Cooling mode, except outdoor-fan motor stops and a bank of optional electric heat turns on to warm air supplying the conditioned space.

Auxiliary Heating - If accessory electric heaters are installed, on a call for heat, circuit R-W is made through the thermostat contacts. Circuit R-G is made which energizes the IFR. If the heaters are staged, then the thermostat closes a second set of contacts W2 when second stage is required. When thermostat is satisfied, contacts open, deenergizing the heater relay and the IFR.

ECM Blower Motor Units (048-060)

Heat Pump Heating - On a call for heat, thermostat makes circuits R-Y and R-G. When compressor time delay (5 +/- 2 minutes) is completed, a circuit is made to C, starting COMP and OFM. Circuit R-G also energizes IFR and starts IFM after 1-sec. delay.

Should room temperature continue to fall, circuit R-W is made through second-stage thermostat bulb. If optional electric heat package is used, a relay is energized, bringing on first bank of supplemental electric heat. At this time, the airflow (CFM) will be either the AUX HEAT RANGE (VIO) setting or the AC/HP SIZE (BLU) setting, whichever is greater. This may be a noticeable change in airflow. When thermostat is satisfied, contacts open, deenergizing contactor and relay; motors and heaters deenergize. The IFM has a time delay relay that keeps the fan on for 30-sec.

Defrost Mode - Defrost board (DB) is a time and temperature control, which includes a field-selectable time period between checks for defrost (30, 50 or 90 minutes). Electronic timer and defrost cycle start only when contactor is energized and defrost thermostat (DFT) is closed.

Defrost mode is identical to Cooling mode, except outdoor-fan motor stops and a bank of optional electric heat turns on to warm air supplying the conditioned space.

Auxiliary Heating - If accessory electric heaters are installed, on a call for heat, circuits R-W and R-G are made through the thermostat contacts, energizing the heater relay and IFM. If the heaters are staged, then the thermostat closes the second set of contacts, W2, when the second stage is required. When the thermostat is satisfied, contacts open, deenergizing the heater relay and the IFM.

MAINTENANCE

To ensure continuing high performance, and to minimize the possibility of premature equipment failure, periodic maintenance must be performed on this equipment. This cooling unit should be inspected at least once each year by a qualified service person. To troubleshoot cooling of units, refer to tables at the back of the book.

NOTE TO EQUIPMENT OWNER: Consult your local dealer about the availability of a maintenance contract.

▲ WARNING

The ability to properly perform maintenance on this equipment requires certain expertise, mechanical skills, tools, and equipment. If you do not possess these, do not attempt to perform any maintenance on this equipment other than those procedures recommended in the User's Manual. FAILURE TO HEED THIS WARNING COULD RESULT IN SERIOUS PERSONAL INJURY AND POSSIBLE DAMAGE TO THIS EQUIPMENT.

▲ WARNING

Failure to follow these warnings could result in serious personal injury:

1. Turn off electrical power to the unit and install lockout tag before performing any maintenance or service on the unit.
2. Use extreme caution when removing panels and parts. As with any mechanical equipment, personal injury can result from sharp edges, etc.
3. Never place anything combustible either on, or in contact with, the unit.

▲ CAUTION

Errors made when reconnecting wires may cause improper and dangerous operation. Label all wires prior to disconnection when servicing.

The minimum maintenance requirements for this equipment are as follows:

1. Inspect air filter(s) each month. Clean or replace when necessary.
2. Inspect indoor coil, drain pan, and condensate drain at least each cooling season for cleanliness. Clean when necessary.
3. Inspect blower motor and wheel for cleanliness and check lubrication each heating and cooling season. Clean when necessary.
4. Check electrical connections for tightness and controls for proper operation each heating and cooling season. Service when necessary.
5. Ensure electric wires are not in contact with refrigerant tubing or sharp metal edges.

AIR FILTER

▲ CAUTION

Never operate the unit without a suitable air filter in the return-air duct system. Always replace the filter with the same size as originally installed. See Table 1 for recommended filter sizes.

Inspect air filter(s) at least once each month and replace (throwaway-type) or clean (cleanable-type) at least twice during each heating and cooling season or whenever the filter(s) becomes clogged with dust and lint.

**Table 8—Dry Coil Air Delivery (Deduct 10 percent for 208v)*
Horizontal and Downflow Discharge
Unit 50HX024-042**

230 AND 460 VOLT													
Unit	Motor Speed		External Static Pressure (in. wg)										
			0.0	0.1	0.2	0.3	0.4	0.5	0.6	0.7	0.8	0.9	1.0
024 & 030	Low	Watts	280	275	265	255	250	245	240	—	—	—	—
		Cfm	820	810	755	700	660	600	560	—	—	—	—
	Med	Watts	365	360	350	345	340	330	320	310	300	—	—
		Cfm	1025	1010	975	940	900	850	800	720	630	—	—
	High	Watts	—	—	490	480	470	460	445	430	410	390	380
		Cfm	—	—	1300	1255	1200	1150	1080	1005	915	790	620
036	Low	Watts	520	495	474	458	445	425	—	—	—	—	—
		Cfm	1375	1335	1290	1240	1200	1140	—	—	—	—	—
	Med	Watts	575	560	535	510	480	460	440	425	—	—	—
		Cfm	1520	1490	1450	1400	1380	1300	1200	1080	—	—	—
	High	Watts	—	—	—	—	650	614	575	540	510	480	—
		Cfm	—	—	—	—	1560	1500	1380	1280	1170	1060	—
042	Low	Watts	490	480	470	460	450	430	410	390	—	—	—
		Cfm	1400	1380	1340	1300	1250	1200	1140	1070	—	—	—
	Med	Watts	590	580	560	545	525	505	480	450	420	—	—
		Cfm	1600	1560	1540	1470	1430	1360	1300	1220	1120	—	—
	High	Watts	—	—	—	—	—	700	670	640	600	560	500
		Cfm	—	—	—	—	—	1780	1670	1600	1480	1340	1100

* Air delivery values are based on operating voltage of 230-v dry coil, without filter or electric heater. Deduct wet coil, filter and electric heater pressure drops to obtain static pressure available for ducting.

NOTES:

1. Do not operate the unit at a cooling airflow that is less than 350 cfm for each 12,000 Btuh of rated cooling capacity. Indoor coil frosting may occur at airflows below this point.
2. Dashes indicate portions of table that are beyond the blower motor capacity or are not recommended.

Table 9—048 & 060 ECM Airflow (CFM)

UNIT 50HX	FAN ONLY (CFM)	COOLING (CFM)
048	1400	1600
060	1750	2000

UNIT TOP REMOVAL

NOTE: When performing maintenance or service procedures that require removal of the unit top, be sure to perform all of the routine maintenance procedures that require top removal, including coil inspection and cleaning, and condensate drain pan inspection and cleaning.

Only qualified service personnel should perform maintenance and service procedures that require unit top removal. Refer to the following top removal procedures:

1. Remove 7 screws on unit top cover surface. (Save all screws.)
2. Remove 4 screws on unit top cover flange. (Save all screws.)
3. Lift top from unit carefully. Set top on edge and make sure that top is supported by unit side that is opposite duct (or plenum) side.
4. Carefully replace and secure unit top to unit, using screws removed in Steps 1 and 2, when maintenance and/or service procedures are completed.

INDOOR BLOWER AND MOTOR

NOTE: Motors without oilers are prelubricated. Do not attempt to lubricate these motors.

For longer life, operating economy, and continuing efficiency, clean accumulated dirt and grease from the blower wheel and motor annually.

Lubricate the motor every 5 years if the motor is used intermittently (thermostat FAN switch in AUTO. position), or every 2 years if the motor is used continuously (thermostat FAN switch in ON position).

⚠ WARNING
Disconnect and tag electrical power to the unit before cleaning the blower motor and wheel. Failure to adhere to this warning could cause personal injury or death.

To clean the blower motor and wheel:

1. Remove and disassemble blower assembly as follows:
 - a. Remove unit access panel.
 - b. *For PSC Blower Motors* Disconnect motor lead from indoor fan relay (IFR). Disconnect yellow lead from terminal L2 of the contactor.
 - c. On all units remove blower assembly from unit. Remove screws securing blower and slide assembly out. Be careful not to tear insulation in blower compartment.
 - d. Ensure proper reassembly by marking blower wheel and motor in relation to blower housing before disassembly.
 - e. Loosen setscrew(s) that secures wheel to motor shaft, remove screws that secure motor mount brackets to housing, and slide motor and motor mount out of housing.

Table 10—Wet Coil Pressure Drop

UNIT SIZE	AIRFLOW (CFM)	PRESSURE DROP (IN. WG)
024	600	0.039
	700	0.058
	800	0.075
	900	0.088
030	900	0.088
	1000	0.095
	1200	0.123
036	1000	0.068
	1200	0.088
	1400	0.108
	1600	0.123
042	1000	0.048
	1200	0.069
	1400	0.088
	1600	0.102
048	1400	0.068
	1550	0.073
	1600	0.075
	1800	0.088
060	1700	0.082
	1900	0.095
	2100	0.108
	2300	0.123

Table 11—Accessory Electric Heater Pressure Drop (in. wg)

HEATER KW	CFM								
	600	800	1000	1200	1400	1600	1800	2000	2200
5–20	0.030	0.033	0.037	0.042	0.047	0.052	0.060	0.067	0.075

Table 12—Filter Pressure Drop (in. wg)

UNIT SIZE	FILTER SIZE (IN.)																			
		500	600	700	800	900	1000	1100	1200	1300	1400	1500	1600	1700	1800	1900	2000	2100	2200	2300
024–036	24 x 24 x 1	—	—	0.06	0.06	0.07	0.07	0.08	0.09	0.10	—	—	—	—	—	—	—	—	—	—
042–060	24 x 30 x 1	—	—	—	—	—	—	—	—	0.08	0.09	0.09	0.10	0.11	0.12	0.13	0.14	0.15	0.17	0.18

2. Lubricate motor as follows:
 - a. Thoroughly clean all accumulations of dirt or grease from motor housing.
 - b. Remove dust caps or plugs from oil ports located at each end of motor.
 - c. Use a good grade of SAE 20 non-detergent motor oil and put one teaspoon (1.16 oz. or 16 to 25 drops) in each oil port.
 - d. Allow time for oil to be absorbed by each bearing, then wipe excess oil from motor housing.
 - e. Replace dust caps or plugs in oil ports.
3. Remove and clean blower wheel as follows:
 - a. Ensure proper reassembly by marking wheel orientation.
 - b. Remove screws holding cut-off plate, and remove plate from housing.
 - c. Lift wheel from housing. When handling and/or cleaning blower wheel, be sure not to disturb balance weights (clips) on blower wheel vanes.
 - d. Remove caked-on dirt from wheel and housing with a brush. Remove lint and/or dirt accumulations from wheel and housing with vacuum cleaner, using soft brush attachment. Remove grease and oil with mild solvent.
 - e. Reassemble wheel and cut-off plate into housing.
 - f. Reassemble motor into housing. Be sure setscrews are tightened on motor shaft flats and not on round part of shaft.
 - g. Reinstall unit access panel.
4. Restore electrical power to unit. Start unit and check for proper blower rotation and motor speeds during heating and cooling cycles.

OUTDOOR COIL, INDOOR COIL, AND CONDENSATE DRAIN PAN

Inspect the outdoor coil, indoor coil, and condensate drain pan at least once each year. See *Unit Top Removal* section.

The coils are easily cleaned when dry; therefore, inspect and clean the coils either before or after each cooling season. Remove all obstructions, including weeds and shrubs, that interfere with the airflow through the outdoor coil.

Table 13A—Superheat Charging Table, Unit 024–311

TEMP (F) AIR ENT COND		EVAP AIR – CFM										
		800										
		EVAP AIR – Ewb (F)										
		56	58	60	62	64	66	68	70	72	74	76
65	SPH	—	—	24.0	27.4	30.8	31.1	31.5	30.5	29.5	29.2	28.9
70		—	—	19.5	24.4	29.3	29.9	30.4	29.5	28.6	28.2	27.8
75		—	—	15.0	21.4	27.8	28.6	29.4	28.5	27.7	27.2	26.7
80		—	—	7.5	14.4	21.4	24.5	27.6	27.1	26.5	26.1	25.6
85		—	—	—	7.5	15.0	20.4	25.8	25.6	25.4	24.9	24.5
90		—	—	—	—	7.5	14.0	20.4	22.3	24.2	23.8	23.4
95		—	—	—	—	—	7.5	15.0	19.0	23.1	22.7	22.3
100		—	—	—	—	—	—	7.5	13.5	19.5	20.3	21.1
105		—	—	—	—	—	—	—	8.0	16.0	18.0	20.0
110		—	—	—	—	—	—	—	—	12.4	15.7	18.9
115		—	—	—	—	—	—	—	—	8.9	13.3	17.8

Ewb-Entering Wet Bulb
 SPH-Superheat at Compressor (F)
 --Do not attempt to charge system under these conditions as refrigerant slugging may occur.

Table 13B—Superheat Charging Table, Unit 024–321

TEMP (F) AIR ENT COND		EVAP AIR – CFM										
		750										
		EVAP AIR – Ewb (F)										
		56	58	60	62	64	66	68	70	72	74	76
65	SPH	38.0	37.3	37.4	37.5	38.3	37.7	36.8	35.9	35.0	34.3	33.5
70		33.3	32.3	33.2	33.9	36.9	36.0	35.2	34.4	33.4	32.5	31.8
75		24.6	25.6	24.1	25.0	33.3	34.8	33.8	32.6	31.8	31.0	30.2
80		16.4	17.6	21.4	16.8	23.2	31.8	32.2	31.3	30.4	29.5	28.6
85		—	—	9.4	8.6	14.7	21.6	29.4	29.8	28.9	27.8	27.0
90		—	—	—	—	—	11.6	18.9	26.4	27.3	26.4	25.5
95		—	—	—	—	—	3.7	10.8	18.0	24.1	25.0	24.1
100		—	—	—	—	—	—	—	8.0	16.3	22.1	22.6
105		—	—	—	—	—	—	—	—	7.2	14.8	20.1
110		—	—	—	—	—	—	—	—	—	5.2	13.8
115		—	—	—	—	—	—	—	—	—	—	5.1

Ewb-Entering Wet Bulb
 SPH-Superheat at Compressor (F)
 --Do not attempt to charge system under these conditions as refrigerant slugging may occur.

Table 13C—Superheat Charging Table, Unit 030

TEMP (F) AIR ENT COND		EVAP AIR – CFM										
		1000										
		EVAP AIR – Ewb (F)										
		56	58	60	62	64	66	68	70	72	74	76
65	SPH	5.5	5.5	5.5	12.5	19.6	26.6	26.9	27.2	27.5	26.5	25.4
70		—	—	—	10.5	17.5	24.5	24.8	25.1	25.4	25.1	24.8
75		—	—	—	8.4	15.5	22.5	22.8	23.1	23.4	23.8	24.2
80		—	—	—	6.8	12.9	18.9	20.3	21.5	22.9	23.0	23.0
85		—	—	—	5.1	10.2	15.4	17.7	20.1	22.3	22.1	21.8
90		—	—	—	—	7.9	11.9	15.2	18.5	21.8	21.5	21.2
95		—	—	—	—	5.6	8.4	12.7	17.0	21.2	20.8	20.6
100		—	—	—	—	—	—	9.2	14.1	19.1	19.5	19.9
105		—	—	—	—	—	—	5.7	11.4	17.1	18.2	19.3
110		—	—	—	—	—	—	5.0	10.0	15.1	16.9	18.6
115		—	—	—	—	—	—	—	8.7	13.0	15.5	18.0

Ewb-Entering Wet Bulb
 SPH-Superheat at Compressor (F)
 --Do not attempt to charge system under these conditions as refrigerant slugging may occur.

Straighten bent fins with a fin comb. If coated with dirt or lint, clean the coils with a vacuum cleaner, using the soft brush attachment. Be careful not to bend the fins. If coated with oil or grease, clean the coils with a mild detergent-and-water solution.

Rinse coils with clear water, using a garden hose. Be careful not to splash water on motors, insulation, wiring, or air filter(s). For best results, spray outdoor coil fins from inside to outside the unit. On

Table 13D—Superheat Charging Table, Unit 036

TEMP (F) AIR ENT COND		EVAP AIR – CFM										
		1150										
		EVAP AIR – Ewb (F)										
		56	58	60	62	64	66	68	70	72	74	76
65	SPH	28.6	28.6	30.4	32.1	33.3	34.3	33.4	32.0	30.7	29.8	28.9
70		23.8	23.8	25.5	27.2	29.5	32.3	32.0	30.9	29.7	28.6	27.6
75		19.0	19.1	20.6	22.2	25.7	30.4	30.6	29.7	28.7	27.5	26.3
80		15.0	15.0	15.8	16.5	21.1	26.5	27.7	27.8	27.8	26.6	25.3
85		10.9	10.9	10.9	10.9	16.6	22.6	24.8	25.9	26.9	25.6	24.3
90		7.7	7.7	7.0	8.3	12.6	19.1	21.5	23.4	25.3	24.4	23.6
95		—	—	—	—	8.6	14.5	16.5	20.9	23.6	23.3	22.9
100		—	—	—	—	—	11.3	14.3	17.4	20.4	21.1	21.8
105		—	—	—	—	—	7.1	10.5	13.9	17.2	19.0	20.8
110		—	—	—	—	—	—	7.1	11.7	16.4	18.2	19.9
115		—	—	—	—	—	—	—	9.6	15.5	17.3	19.1

Ewb-Entering Wet Bulb
 SPH-Superheat at Compressor (F)
 --Do not attempt to charge system under these conditions as refrigerant slugging may occur.

Table 13E—Superheat Charging Table, Unit 042

TEMP (F) AIR ENT COND		EVAP AIR – CFM										
		1400										
		EVAP AIR – Ewb (F)										
		56	58	60	62	64	66	68	70	72	74	76
65	SPH	13.5	13.5	13.5	17.1	20.7	24.3	25.7	27.1	28.5	27.8	27.0
70		11.4	11.4	11.5	15.1	18.7	22.3	23.6	25.1	26.4	26.1	25.8
75		9.4	9.4	9.4	13.0	16.5	20.1	21.6	23.0	24.4	24.5	24.6
80		8.9	8.9	8.9	12.4	16.0	19.4	21.0	22.4	23.8	24.0	24.0
85		8.2	8.2	8.2	11.8	15.3	18.7	20.2	21.8	23.3	23.4	23.4
90		7.7	7.7	7.7	10.8	13.7	16.7	18.7	20.7	22.7	22.7	22.9
95		7.2	7.2	7.2	9.7	12.2	14.6	17.2	19.7	22.2	22.3	22.3
100		6.6	6.6	6.6	9.6	12.6	15.5	17.6	19.7	21.6	21.7	21.7
105		6.1	6.1	6.1	9.6	13.1	16.5	18.0	19.5	21.1	21.1	21.2
110		—	—	—	7.0	9.9	13.0	15.0	17.1	19.1	19.8	20.6
115		—	—	—	—	6.9	9.4	11.9	14.5	17.0	18.5	20.0

Ewb-Entering Wet Bulb
 SPH-Superheat at Compressor (F)
 --Do not attempt to charge system under these conditions as refrigerant slugging may occur.

Table 13F—Superheat Charging Table, Unit 048–301

TEMP (F) AIR ENT COND		EVAP AIR – CFM										
		1600										
		EVAP AIR – Ewb (F)										
		56	58	60	62	64	66	68	70	72	74	76
65	SPH	26.3	27.0	27.6	28.6	29.6	30.5	30.9	31.3	31.7	31.2	30.7
70		24.0	23.8	23.6	25.0	26.4	27.8	28.4	29.0	29.7	29.6	29.5
75		19.7	19.7	19.7	21.4	23.2	25.0	25.9	26.8	27.6	27.9	28.2
80		15.8	15.8	15.8	17.6	19.4	21.2	22.7	24.1	25.6	26.2	26.9
85		12.0	12.0	12.0	13.8	15.6	17.5	19.5	21.5	23.5	24.5	25.6
90		7.5	7.5	7.5	9.4	11.3	13.2	16.3	19.3	22.4	23.3	24.2
95		—	—	—	5.0	7.0	9.0	13.1	17.1	21.2	22.0	22.8
100		—	—	—	—	—	—	9.4	14.3	19.1	20.3	21.4
105		—	—	—	—	—	—	5.7	11.4	17.1	18.6	20.1
110		—	—	—	—	—	—	—	9.0	13.5	15.8	18.0
115		—	—	—	—	—	—	—	6.7	10.0	13.0	16.0

Ewb-Entering Wet Bulb
 SPH-Superheat at Compressor (F)
 --Do not attempt to charge system under these conditions as refrigerant slugging may occur.

units with an outer and inner (2 row) outdoor coil, be sure to clean between the coils. Be sure to flush all dirt and debris from the unit base.

Inspect the drain pan and condensate drain line when inspecting the coils. Clean the drain pan and condensate drain by removing all

foreign matter from the pan. Flush the pan and drain tube with clear water. Do not splash water on the insulation, motor, wiring, or air filter(s). If the drain tube is restricted, clear it with a “plumbers snake” or similar probe device. Ensure that the auxiliary drain port above the drain tube is also clear

Table 13G—Superheat Charging Table, Unit 048–311

TEMP (F) AIR ENT COND		EVAP AIR – CFM										
		1550										
		EVAP AIR – Ewb (F)										
		56	58	60	62	64	66	68	70	72	74	76
65	SPH	39.4	39.4	40.4	40.6	40.6	40.8	41.0	40.8	40.7	40.2	39.9
70		35.3	35.8	36.8	37.6	37.7	37.8	38.4	38.2	38.4	38.0	37.6
75		31.7	31.4	32.6	34.0	34.5	35.1	35.3	35.5	35.6	35.8	35.5
80		28.1	28.0	28.8	29.8	30.9	31.6	32.8	32.9	32.7	33.0	33.4
85		24.7	24.0	24.6	26.1	27.5	28.3	29.9	30.3	30.5	30.2	30.7
90		21.2	20.8	19.3	21.0	23.4	25.0	26.6	27.4	27.9	28.1	28.0
95		16.5	16.1	16.3	16.5	18.8	21.2	22.7	23.9	25.4	25.7	25.9
100		12.4	7.5	5.6	11.5	14.9	16.8	19.1	21.4	22.0	23.3	23.5
105		—	—	—	—	9.7	12.7	15.2	18.3	19.5	20.2	21.1
110		—	—	—	—	—	7.7	11.2	13.7	16.7	17.8	18.5
115		—	—	—	—	—	—	—	7.3	10.2	11.8	14.3

Ewb-Entering Wet Bulb
 SPH-Superheat at Compressor (F)
 -- Do not attempt to charge system under these conditions as refrigerant slugging may occur.

Table 13H—Superheat Charging Table, Unit 060

TEMP (F) AIR ENT COND		EVAP AIR – CFM										
		1800										
		EVAP AIR – Ewb (F)										
		56	58	60	62	64	66	68	70	72	74	76
65	SPH	21.0	21.0	21.0	22.8	24.7	26.5	27.8	29.1	30.4	29.5	28.6
70		16.5	16.5	16.5	18.8	21.1	23.5	25.2	27.0	28.8	28.2	27.6
75		12.0	12.0	12.0	14.8	17.6	20.4	22.7	24.9	27.2	26.9	26.6
80		10.5	10.5	10.5	12.7	14.9	17.1	19.8	22.5	25.2	25.4	25.5
85		9.0	9.0	9.0	10.6	12.3	13.9	17.0	20.0	23.1	23.8	24.5
90		4.5	4.5	4.5	6.5	8.5	10.5	14.3	18.1	21.9	22.7	23.5
95		—	—	—	—	4.8	7.2	11.7	16.2	20.7	21.6	22.5
100		—	—	—	—	—	3.6	8.6	13.6	18.6	20.0	21.4
105		—	—	—	—	—	—	5.5	11.1	16.6	18.5	20.4
110		—	—	—	—	—	—	—	10.0	15.5	17.5	19.4
115		—	—	—	—	—	—	—	9.2	14.7	16.5	18.5

Ewb-Entering Wet Bulb
 SPH-Superheat at Compressor (F)
 -- Do not attempt to charge system under these conditions as refrigerant slugging may occur.

OUTDOOR FAN

⚠ CAUTION

Keep the outdoor fan free from all obstructions to ensure proper cooling operation. Never place articles on top of the unit. Damage to unit may result.

1. Remove 2 screws at bottom of outdoor air intake grille and remove plastic grille.
2. Inspect the fan blades for cracks or bends.
3. If fan needs to be removed, loosen the setscrew and slide the fan off the motor shaft.
4. When replacing fan blade, position blade so that the leading edge is 2-in. back from outdoor inlet grille or 1/2-in. maximum from fan deck (See Fig. 25).
5. Ensure that setscrew engages the flat area on the motor shaft when tightening
6. Replace grille.

ELECTRICAL CONTROLS AND WIRING

Inspect and check the electrical controls and wiring annually. *Be sure to turn off the electrical power to the unit and install lockout tag.*

Remove the control/blower and compressor compartment access panels to locate all the electrical controls and wiring. Check all electrical connections for tightness. Tighten all screw connections. If any smoky or burned connections are noticed, disassemble the connection, clean all the parts, restrip the wire end and reassemble the connection properly and securely.

After inspecting the electrical controls and wiring, replace the access panel. Start the unit, and observe at least one complete heating cycle and one complete cooling cycle to ensure proper operation. If discrepancies are observed in either or both operating cycles, or if a suspected malfunction has occurred, check each electrical component with the proper electrical instrumentation. Refer to the unit wiring label when making these checkouts.

NOTE: Refer to the heating and/or cooling sequence of operation in this publication as an aid in determining proper control operation

REFRIGERANT CIRCUIT

Inspect all refrigerant tubing connections and the unit base for oil accumulations annually. Detecting oil generally indicates a refrigerant leak.

Required Suction Tube Temperature

SUPERHEAT TEMP (F)	SUCTION PRESSURE AT SERVICE PORT (Psig)								
	61.5	64.2	67.1	70	73	76	79.2	82.4	85.7
0	35	37	39	41	43	45	47	49	51
2	37	39	41	43	45	47	49	51	53
4	39	41	43	45	47	49	51	53	55
6	41	43	45	47	49	51	53	55	57
8	43	45	47	49	51	53	55	57	59
10	45	47	49	51	53	55	57	59	61
12	47	49	51	53	55	57	59	61	63
14	49	51	53	55	57	59	61	63	65
16	51	53	55	57	59	61	63	65	67
18	53	55	57	59	61	63	65	67	69
20	55	57	59	61	63	65	67	69	71
22	57	59	61	63	65	67	69	71	73
24	59	61	63	65	67	69	71	73	75
26	61	63	65	67	69	71	73	75	77
28	63	65	67	69	71	73	75	77	79
30	65	67	69	71	73	75	77	79	81
32	67	69	71	73	75	77	79	81	83
34	69	71	73	75	77	79	81	83	85
36	71	73	75	77	79	81	83	85	87
38	73	75	77	79	81	83	85	87	89
40	75	77	79	81	83	85	87	89	91

NOTE: Measure suction tube temperature with accurate superheat thermometer or thermistor-type thermometer

C95030

Fig. 30—Required Suction Tube Temperature (F) *

⚠ WARNING

System under pressure. Relieve pressure and recover all refrigerant before system repair or final unit disposal to avoid personal injury or death. Use all service ports and open all flow-control devices, including solenoid valves.

If oil is detected or if low cooling performance is suspected, leak-test all refrigerant tubing using an electronic leak-detector, halide torch, or liquid-soap solution. If a refrigerant leak is detected, refer to Check for Refrigerant Leaks section.

If no refrigerant leaks are found and low cooling performance is suspected, refer to Checking and Adjusting Refrigerant Charge section.

INDOOR AIRFLOW

The heating and/or cooling air-flow does not require checking unless improper performance is suspected. *If a problem exists, be sure that all supply- and return-air grilles are open and free from obstructions, and that the air filter is clean.* When necessary, refer to Indoor Airflow and Airflow Adjustments section to check the system airflow.

METERING DEVICE — ACUTROL DEVICE

This unit uses metering devices that are of the fixed orifice type (located in the header to the indoor and outdoor coils).

LIQUID LINE STRAINER

The liquid line strainer (to protect metering device) is made of wire mesh and located in the liquid line on the inlet side of the metering device.

TROUBLESHOOTING

Use the *Troubleshooting—Cooling & Heating* guide (see Table 13) if problems occur with these units.

START-UP CHECKLIST

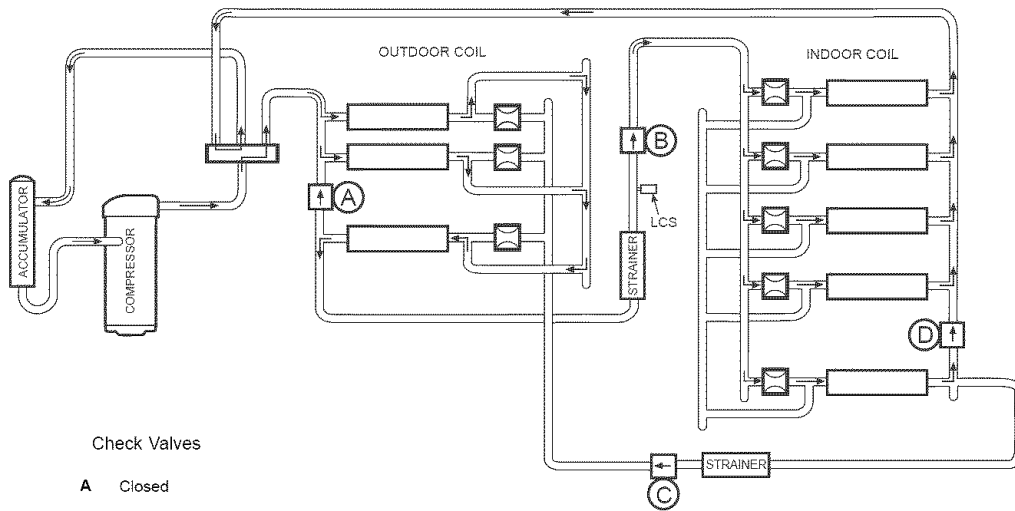

Use the Start-Up checklist to ensure proper start-up procedures are followed.



Check Valves

- A Closed
- B Open
- C Closed
- D Open

LEGEND

- LCS** Loss of Charge Switch
-  Acutrol Metering Device
-  Check Valve (Arrow indicates direction of flow)

COOLING CYCLE

1. Hot gas from compressor flows through the 4-way valve and is directed to the heating liquid line check valve. It is then condensed and subcooled through converging circuits. Refrigerant leaves the outdoor coil by way of the strainer and the check valve in the cooling liquid line.
2. The refrigerant then feeds the indoor coil through the Acutrol metering device on each circuit.
3. Each circuit evaporates the refrigerant and the circuits are combined in the indoor coil header with some of the circuits flowing through the check valve.
4. The refrigerant then flows through the 4-way valve, accumulator, and back to the compressor.

C95044

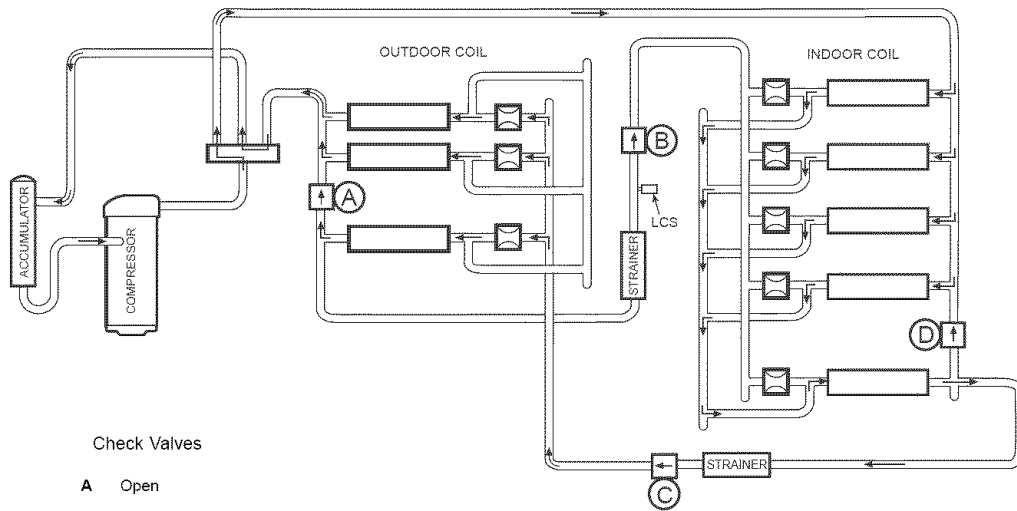

Fig. 31—Typical Heat Pump Operation-Cooling Mode



Check Valves

- A** Open
- B** Closed
- C** Open
- D** Closed

LEGEND

- LCS** Loss of Charge Switch
-  Acutrol Metering Device
-  Check Valve (Arrow indicates direction of flow)

HEATING CYCLE

1. Hot gas from compressor flows through the 4-way valve and is directed to the cooling liquid line check valve. It is then condensed and directed through subcooling circuits and out to the strainer and the check valve in the heating liquid line.
2. The refrigerant then feeds the outdoor coil through the Acutrol metering device on each circuit.
3. Each circuit evaporates the refrigerant and the circuits are combined in the outdoor header with some of the circuits flowing through the check valve.
4. The refrigerant then flows through the 4-way valve, accumulator, and back to the compressor.

C95045

Fig. 32—Typical Heat Pump Operation-Heating Mode

Table 14—Troubleshooting Chart

SYMPTOM	CAUSE	REMEDY
Compressor and outdoor fan will not start	Power Failure	Call power company
	Fuse blown or circuit breaker tripped	Replace fuse or reset circuit breaker
	Defective thermostat, contactor, transformer, control relay, defrost board, or high pressure or loss-of-charge/low pressure switch	Replace component
	Insufficient line voltage	Determine cause and correct
	Incorrect or faulty wiring	Check wiring diagram and rewire correctly
	Thermostat setting too high	Lower thermostat setting below room temperature
Compressor will not start but condenser fan runs	Faulty wiring or loose connections in compressor circuit	Check wiring and repair or replace
	Compressor motor burned out, seized, or internal overload open	Determine cause. Replace compressor
	Defective run capacitor, overload, or PTC (positive temperature coefficient) thermistor	Determine cause and replace
	Low input voltage (20 percent low)	Determine cause and correct
Compressor cycles (other than normally satisfying thermostat)	Refrigerant overcharge or undercharge	Recover refrigerant, evacuate system, and recharge to capacities shown on nameplate
	Defective compressor	Replace and determine cause
	Insufficient line voltage	Determine cause and correct
	Blocked outdoor coil	Determine cause and correct
	Defective run/start capacitor, overload or start relay	Determine cause and replace
	Defective thermostat	Replace thermostat
	Faulty outdoor-fan motor or capacitor	Replace
	Damaged reversing valve	Determine cause and correct
Compressor operates continuously	Restriction in refrigerant system	Locate restriction and remove
	Dirty air filter	Replace filter
	Unit undersized for load	Decrease load or increase unit size
	Thermostat set too low	Reset thermostat
	Low refrigerant charge	Locate leak, repair, and recharge
	Frosted coil with incorrect defrost operation	Check defrost time settings Reset as necessary Check defrost temperature switch Replace as necessary
	Air in system	Recover refrigerant, evacuate system, and recharge
Excessive head pressure	Outdoor coil dirty or restricted	Clean coil or remove restriction
	Dirty air filter	Replace filter
	Dirty indoor or outdoor coil	Clean coil
	Refrigerant overcharged	Recover excess refrigerant
	Air in system	Recover refrigerant, evacuate system, and recharge
	(Heat) Indoor air restricted or recirculating	Determine cause and correct
	Indoor or outdoor air restricted or air short-cycling	Determine cause and correct

(Continued next page)

Table 14—Troubleshooting Chart (Cont'd)

SYMPTOM	CAUSE	REMEDY
Head pressure too low	Low refrigerant charge	Check for leaks, repair and recharge
	Restriction in liquid tube	Remove restriction
Excessive suction pressure	(Heat) Outdoor coil frosted	Move timer on control board to 30 minutes between defrost cycles
	(Cool) High Heat load	Check for source and eliminate
	Reversing valve hung up or leaking internally	Replace valve
	Refrigerant overcharged	Recover excess refrigerant
Suction pressure too low	(Cool) Dirty air filter	Replace filter
	(Heat) Outdoor coil frosted	Move timer on control board to 30 minutes between defrost cycles
	Low refrigerant charge	Check for leaks, repair and recharge
	Metering device or low side restricted	Remove source of restriction
	(Cool) Insufficient coil airflow	Increase air quantity Check filter—replace if necessary
	(Cool) Temperature too low in conditioned area	Reset thermostat
	(Cool) Outdoor ambient below 40°F	Install low-ambient kit
Compressor runs but outdoor fan does not	Filter-drier restricted	Replace
	NC (normally closed) contacts on defrost board open	Check condition of relay on board Replace if necessary
IFM does not run	Blower wheel not secured to shaft	Properly tighten blower wheel to shaft
	Insufficient voltage at motor	Determine cause and correct
	Power connectors not properly sealed	Connectors should snap easily; do not force
IFM operation is intermittent	Water dripping into motor	Verify proper drip loops in connector wires
	Connectors not firmly sealed	Gently pull wires individually to be sure they are crimped into the housing
IFM (048-060) runs when it should be off	Motor programmed with a delay profile	Allow a few minutes for motor to shut off
	With thermostat in "off" mode, the voltage on G, Y1, Y2, W with respect to common, should be 1/2 of actual low voltage supply	If measured voltage is more than 1/2, the thermostat is incompatible with motor. If voltage is less than 1/2, the motor has failed

IFM—Indoor Fan Motor

**START-UP CHECKLIST
(REMOVE AND STORE IN JOB FILE)**

I. PRELIMINARY INFORMATION

Model No
Serial No
Date
Technician
Job/ Location.....

II. PRE-START-UP

- Verify that all packing materials have been removed from unit
- Verify that condensate connection is installed per installation instructions
- Check all electrical connections and terminals for tightness
- Check that indoor (evaporator) air filter is clean and in place
- Verify that unit installation is level
- Check fan wheel propeller for location in housing and setscrew tightness

III. START-UP

Supply Voltage: C-S _____ S-R _____ R-C _____
Compressor Amps: C _____ S _____ R _____
Indoor (Evaporator) Fan Amps: _____

TEMPERATURE

Outdoor (Condenser) Air Temperature: _____ DB
Return-Air Temperature: _____ DB _____ WB
Cooling Supply Air: _____ DB _____ WB

PRESSURES

Refrigerant Suction _____ psig
Suction Line Temp* _____
Refrigerant Discharge _____ psig
Discharge Temp† _____
 Verify Refrigerant charge using charging tables

* Measured at suction inlet to compressor

† Measured at liquid line leaving outdoor coil

Free Manuals Download Website

<http://myh66.com>

<http://usermanuals.us>

<http://www.somanuals.com>

<http://www.4manuals.cc>

<http://www.manual-lib.com>

<http://www.404manual.com>

<http://www.luxmanual.com>

<http://aubethermostatmanual.com>

Golf course search by state

<http://golfingnear.com>

Email search by domain

<http://emailbydomain.com>

Auto manuals search

<http://auto.somanuals.com>

TV manuals search

<http://tv.somanuals.com>