

**SEARS**

**CRAFTSMAN**

**Model No.  
919.726600**

**IMPORTANT:**  
Read the Safety Guidelines  
and All Instructions Carefully  
Before Operating

**SAFETY GUIDELINES  
ASSEMBLY  
OPERATION  
MAINTENANCE  
TROUBLESHOOTING  
REPAIR PARTS**



**OWNERS MANUAL FOR**

**CRAFTSMAN  
• TWIN-V OILFREE •  
TANK MOUNTED  
AIR COMPRESSOR**

Record in the spaces provided.

- (1) The Model Number can be found on the maintenance label on top of the motor shroud or on the bar code label on the rear of air tank.
- (2) The Date Code Number can be found on the bar code label on the rear of the air tank.
- (3) The Serial Number can be found on the bar code label on the rear of the tank.
- (4) The Tank Registration Number is located on the metal data plate which is welded onto the backside of the air tank. (This data plate is painted the same color as the tank.)

Retain these numbers for future reference.

Model No \_\_\_\_\_

Serial No \_\_\_\_\_

Date Code \_\_\_\_\_

Tank Registration No \_\_\_\_\_

**Sold by Sears Canada, Inc., Toronto, Ont. M5B 2B8**

**MGP-726600 1/30/96**

---

# TABLE OF CONTENTS

---

	Page
WARRANTY .....	2
SAFETY GUIDELINES .....	3
WARNING CHART .....	3
GENERAL INFORMATION .....	5
GLOSSARY .....	5
SPECIFICATION CHART .....	5
DESCRIPTION OF OPERATION .....	6
TOOLS NEEDED FOR ASSEMBLY .....	6
ASSEMBLY .....	7
BREAK-IN PROCEDURES .....	7
Location of Air Compressor .....	7
Lubrication and Oil .....	7
Grounding Instructions .....	7
Voltage and Circuit Protection .....	8
Break-in Procedure .....	8
OPERATING PROCEDURES .....	8
MAINTENANCE .....	9
Air Filter - Inspection and Replacement .....	9
Check Valve -Replacement .....	9
Safety Valve - Inspection .....	9
Motor .....	9
Storage .....	9
TROUBLESHOOTING GUIDE .....	10
AIR COMPRESSOR DIAGRAM .....	12
COMPRESSOR PUMP DIAGRAM .....	14
HOW TO ORDER REPAIR PARTS .....	18

## **FULL ONE YEAR WARRANTY ON AIR COMPRESSORS**

If this air compressor fails due to a defect in material or workmanship within one year from the date of purchase, RETURN IT TO THE NEAREST SEARS SERVICE CENTER THROUGHOUT CANADA AND SEARS WILL REPAIR IT, FREE OF CHARGE.

If this air compressor is used for commercial or rental purposes, the warranty will apply for ninety days (90) from the date of purchase.

This Craftsman Air Compressor warranty gives you specific legal rights and you may have other rights which vary from province to province.

**Sears Canada, Inc., Toronto, Ont. M5B 2B8**

# SAFETY GUIDELINES

This manual contains information that is important for you to know and understand. This information relates to protecting YOUR SAFETY and PREVENTING EQUIPMENT PROBLEMS. To help you recognize this information, we use the following symbols. Please read the manual and pay attention to these sections.

## ⚠ DANGER

**URGENT SAFETY INFORMATION - A HAZARD THAT WILL CAUSE SERIOUS INJURY OR LOSS OF LIFE.**

## ⚠ WARNING

**IMPORTANT SAFETY INFORMATION - A HAZARD THAT *MIGHT* CAUSE SERIOUS INJURY OR LOSS OF LIFE.**

## ⚠ CAUTION

**Information for preventing damage to equipment.**

## NOTE

**Information that you should pay special attention to.**

## ⚠ WARNING

**HAZARDS CAN OCCUR IF EQUIPMENT IS NOT USED PROPERLY.  
PLEASE READ THE FOLLOWING CHART.**

WHAT TO LOOK FOR	WHAT COULD HAPPEN	HOW TO PREVENT IT
Hot Parts	The metal compressor components, such as manifold , tubes, etc. become hot when the air compressor is running. If you touch them, you may be seriously burned.	Avoid contact with metal components of the compressor during or immediately after operation. Reaching under or removing portions of the plastic enclosures such as the console cover exposes hot surfaces. Allow compressor to cool prior to servicing.
Flammable Vapors	It is normal for the motor and pressure switch to spark when compressor starts or stops. A spark can ignite vapors from gasoline or solvents, causing a fire or explosion.	If spraying a flammable material, provide ample ventilation. Never spray in a closed area. There must be a flow of fresh air at all times.  Always operate the air compressor in well-ventilated areas, free of gasoline or other solvent vapors. Do not operate the compressor near the spray area.
Air Tank	Modifications to air compressor components in an attempt to reach higher air pressure can cause the air tank to rupture or explode.  Incompatibility between tank and compressor will cause the tank to rupture.  Modifications to the air tank will cause it to weaken.	Do not adjust, remove or tamper with the safety valve or pressure switch. If safety valve or pressure switch replacement is necessary, a part with the same ratings must be used.  Never replace the air tank with a different model or a larger tank. Return to Sears Service Center if replacement is required.  Never drill into, weld or in any way modify the air tank. The tank may rupture or explode. If leaks develop due to corrosion or tank is damaged, return to Sears Service Center for replacement.

# SAFETY GUIDELINES

WHAT TO LOOK FOR	WHAT COULD HAPPEN	HOW TO PREVENT IT
Compressed Air	<p>Compressed air can propel dust, dirt or loose particles. These propelled particles may cause serious injury or damage.</p> <p>Too much air pressure applied to air tools or accessories can cause damage or risk of bursting.</p>	<p>Never point any nozzle or sprayer toward a person or any part of the body.</p> <p>Always wear safety goggles or glasses when using the air compressor.</p> <p>Always turn the air compressor off before attaching or removing accessories.</p> <p>Check the manufacturer's pressure rating for air tools and accessories. Regulator outlet pressure must never exceed the maximum pressure rating.</p>
Electricity	<p>Your air compressor is powered by electricity. Like any other electrically powered device, if it is not used properly it may cause electrical shock.</p>	<p>Always unplug the air compressor prior to maintenance or repair.</p> <p>Never use the air compressor outdoors when it is raining.</p> <p>Always plug the cord into an electrical outlet with the specified voltage and adequate fuse protection.</p>
Toxic Vapors	<p>It is normal for compressed air to contain toxic or irritating vapors. Such vapors are harmful if inhaled.</p> <p>Certain materials you are spraying (like paint, weed killer, sand or insecticide) can be harmful if you inhale them.</p>	<p>Never directly inhale the compressed air produced by this unit.</p> <p>Read labels and safety data for all materials you spray. Follow all safety precautions.</p> <p>Use a mask or respirator if there is a chance of inhaling toxic sprayed materials. Masks and respirators have limits and will only provide protection against some kinds and limited amounts of toxic material. Read mask and respirator instructions carefully. Consult with a safety expert or industrial hygienist if you are not sure about the use of a certain mask or respirator.</p>
Unsuitable Solvents	<p>The solvents 1,1,1 - Trichloroethane and Methylene Chloride can chemically react with aluminum used in paint spray guns, paint pumps, etc., and cause an explosion. These solvents can also react with galvanized components and cause corrosion and weakening of parts. This does not affect your air compressor - but it may affect the equipment being used.</p>	<p>If the material you intend to spray contains the solvents listed at left (read the label or data sheet), do not use accessories that contain aluminum or galvanized parts. You must either change the material you intend to spray, or use only stainless steel spray equipment.</p>

---

# GENERAL INFORMATION

---

You have purchased an air compressor unit consisting of a one cylinder, single-stage air compressor pump and air tank.

This air compressor requires no oil. Now you can enjoy all the benefits of having an air compressor without ever having to purchase, add or change oil.

Your air compressor can be used for operating paint spray guns, air tools, blow guns, nailers/staplers, air brushes,

and inflator kits. An air pressure regulator is required for most of the applications.

An inline air filter which removes moisture and dirt from compressed air should be used where applicable.

An inline regulator can be used if a more precise adjustment of air pressure is needed downstream.

---

## GLOSSARY

---

**CFM:** Cubic Feet per Minute.

**SCFM:** Standard Cubic Feet per Minute; a unit of measure of air delivery.

**PSI:** Pounds per Square Inch; a unit of measure of pressure.

**ASME:** American Society of Mechanical Engineers; made, tested, inspected and registered to meet the standards of the ASME.

**Cut-In Pressure:** While the motor is off, air tank pressure drops as you continue to use your accessory. When the tank pressure drops to a certain low level and the pressure switch lever is in "Auto", the motor will restart automatically. The low pressure at which the motor automatically restarts is called "cut-in pressure."

**Cut-Out Pressure:** When you turn on your air compressor and it begins to run, air pressure in the air tank begins to build. It builds to a certain high pressure before the motor automatically shuts off - protecting your air tank from pressure higher than its capacity. The high pressure at which the motor shuts off is called "cut-out pressure."

**CSA:** Electrical products sold in Canada are required to be certified to the applicable CSA standard (s). Canadian Standards Association (CSA) is a standards writing and safety testing organization. Products that are CSA certified have been evaluated and tested and found to meet or exceed the applicable CSA standard (s) for safety and electrical performance.

---

## SPECIFICATION CHART

---

<b>Model No.</b>	<b>919.726600</b>
Number of Cylinders	2
Bore	2 3/8"
Stroke	1.2"
Voltage - Single Phase	240
Minimum Branch Circuit Requirement	15 amps
Fuse Type	Time Delay
Amperage at Maximum Pressure	15.0
Air Tank/Capacity	ASME/60 gal. (U.S.)
Approximate Cut-in Pressure	100
Approximate Cut-out Pressure	125
SCFM @ 40 psi	15.0
SCFM @ 90 psi	11.5

---

# DESCRIPTION OF OPERATION

---

**Air Compressor Pump:** To compress air, the piston moves up and down in the cylinder. On the downstroke, air is drawn in through the air intake valves. The exhaust valves remain closed. On the upstroke of the piston, air is compressed. The intake valves close and compressed air is forced out through the exhaust valves, through the outlet tube, through the check valve and into the air tank.

**Check Valve:** When the air compressor is operating, the check valve is "open", allowing compressed air to enter the air tank. When the air compressor reaches "cut-out" pressure, the check valve "closes", allowing air pressure to remain inside the air tank.

**Pressure Switch:** The pressure switch is fitted with a small lever. It is labeled "Auto/O" for automatic run or off. In the "O" position, the motor will not run. In the "Auto" position, it automatically starts the motor when the air tank pressure drops below the factory set "cut-in" pressure. It stops the motor when the air tank pressure reaches the factory set "cut-out" pressure.

**Pressure Release Valve:** The pressure release valve located on the side of the pressure switch is designed to automatically release compressed air trapped within the compressor head and outlet tube. This short release of air will occur when the air compressor reaches "cut-out" pressure or the unit is shut off. If the air is not released, the motor will not be able to start when next required.

**Safety Valve:** If the pressure switch does not shut off the air compressor at its cut-out pressure setting, the safety valve will protect the tank against high pressure by "popping out" at its factory set pressure (slightly higher than the pressure switch cut-out setting).

**Regulator:** The air pressure coming FROM the air tank is controlled by the regulator. The regulator control knob is a vibration proof design. Lift the regulator knob to engage and depress the knob to lock. Turn the regulator knob clockwise to increase pressure and counter-clockwise to decrease pressure. To avoid minor readjustment after making a change in pressure setting, always approach the desired pressure from a lower pressure. When reducing from a higher to a lower setting, first reduce to some pressure less than that desired, then bring up to the desired pressure. Depending on the air requirements of each particular accessory, the outlet regulated air pressure may have to be adjusted while operating the accessory.

**Regulator Gauge:** The outlet pressure gauge indicates the air pressure available at the outlet side of the regulator. This pressure is controlled by the regulator and is always less than or equal to the tank pressure. See "Operating Procedures".

**Tank Pressure Gauge:** The tank pressure gauge indicates the reserve air pressure in the tank.

**Cooling System:** This compressor contains an advanced design cooling system. At the heart of this cooling system is an engineered fan. It is perfectly normal for this fan to blow air through the vent holes in large amounts. You know that the cooling system is working when air is being expelled.

**Drain Valve:** This valve is located at the bottom of the tank. To drain accumulated moisture from the tank, pull on the safety valve until tank pressure is 15 PSI. Unscrew the drain valve and allow the water to drain.

---

## TOOLS NEEDED FOR ASSEMBLY

---

- a 9/16" socket and an open end wrench for for removing shipping boards.

# REMOVAL OF SHIPPING BOARDS AND INSTALLATION FOR STATIONARY (PERMANENTLY MOUNTED) UNITS

## ⚠ CAUTION

It may be necessary to brace or support one side of the outfit when removing the shipping boards because the air compressor will have a tendency to tip.

1. Remove all packaging such that only the compressor on the pallet remains. Remove and discard the (4) screws and washers that hold the compressor to the pallet.

2. This compressor is designed to be bolted directly to a level floor. Prior to installing, place the new washers which are supplied with the compressor, between the feet and floor such that the ring base at the bottom of the tank does not contact the floor. Tighten bolts 15-20 ft. lbs.

## BREAK-IN PROCEDURES

### Location of the Air Compressor

Locate the air compressor in a clean, dry and well ventilated area. The air filter must be kept clear of obstructions which could reduce air delivery of the air compressor. The air compressor should be located at least 12" away from the wall or other obstructions that will interfere with the flow of fresh intake and cooling air.

### Lubrication and Oil

This unit needs no lubrication or oiling.

### Grounding Instructions

## ⚠ WARNING

**RISK OF ELECTRICAL SHOCK.** In the event of a short circuit, grounding reduces the risk of shock by providing an escape wire for the electric current. This air compressor must be properly grounded.

This portable air compressor is equipped with a cord having a grounding wire with an appropriate grounding plug. The plug must be used with an outlet that has been installed and grounded in accordance with all local codes and ordinances. The outlet must have the same configuration as the plug.

Inspect the plug and cord before each use. Do not use if there are signs of damage.

## ⚠ DANGER

**IMPROPER GROUNDING CAN RESULT IN ELECTRICAL SHOCK.**

**Do not modify the plug that has been provided. If it does not fit the available outlet, the correct outlet should be installed by a qualified technician.**

If repairing or replacing cord or plug, the grounding wire must be kept separate from the current-carrying wires. Never connect the grounding wire to a flat blade plug terminal. The grounding wire has insulation with an outer surface that is green with or without yellow stripes.

If these grounding instructions are not completely understood, or if in doubt as to whether the compressor is properly grounded, have the installation checked by a qualified electrician.

### 240 VOLT MODELS



20 AMP PLUG



GROUNDING PIN

## Voltage and Circuit Protection

Refer to page 5 (Specification Chart) for the voltage and circuit protection requirements of your compressor. Use only a fuse or circuit breaker that is the same rating as the branch circuit the air compressor is operated on. If the compressor is connected to a circuit protected by fuses, use only dual element time delay fuses.

## Break-in Procedure

### ⚠ CAUTION

**Serious damage may result if the following break-in instructions are not closely followed.**

This procedure is required only once, before the air compressor is put into service.

1. Set the pressure switch "AUTO/O" lever in the "O" position for "Off".
2. Plug the power cord into the correct branch circuit receptacle.
3. Do not attach hose to outlet. Leave the outlet open to the atmosphere.
4. Turn the regulator **clockwise**, opening it fully, to prevent air pressure build-up in the tank.
5. Move the "AUTO/O" lever to "AUTO". The compressor will start.
6. **RUN THE COMPRESSOR FOR 15 MINUTES.** Make sure the regulator is open and there is no tank pressure build-up.
7. After 15 minutes, close the regulator by turning it **counterclockwise**. The air tank will fill to cut-out pressure and then the motor will stop.

---

# OPERATING PROCEDURES

---

1. Before attaching air hose or accessories, make sure the "AUTO/O" lever is set to "O" and the air regulator is closed.
2. Attach hose and accessories.

### ⚠ WARNING

**TOO MUCH AIR PRESSURE CREATES A HAZARDOUS RISK OF BURSTING. CAREFULLY FOLLOW STEPS 3 AND 5 BELOW EACH TIME THE COMPRESSOR IS USED.**

### ⚠ CAUTION

**Compressed air from the outfit may contain water condensation. Do not spray unfiltered air at an item that could be damaged. Some air operated tools or devices may require filtered air. Read the instructions for the air tool or device.**

3. Check the manufacturer's maximum pressure rating for air tools and accessories. The regulator outlet pressure must never exceed the maximum pressure rating.
4. Turn the "AUTO/O" lever to "AUTO" and allow tank pressure to build. Motor will stop when tank pressure reaches "cut-out" pressure.
5. Open the regulator by turning it clockwise. Adjust the regulator to the correct pressure setting. Your compressor is ready for use.

6. Always operate the air compressor in well-ventilated areas; free of gasoline or other solvent vapors. Do not operate the compressor near the spray area.

#### **WHEN YOU ARE FINISHED:**

7. Set the "AUTO/O" lever to "O".
8. Turn the regulator **counterclockwise** and set the outlet pressure to zero.
9. Remove the air tool or accessory.
10. Open the regulator and allow the air to slowly bleed from the tank. Close the regulator when tank pressure is approximately 20 psi.
11. Drain water from air tank.

### ⚠ WARNING

**WATER WILL CONDENSE IN THE AIR TANK. IF NOT DRAINED, WATER WILL CORRODE AND WEAKEN THE AIR TANK CAUSING A RISK OF AIR TANK RUPTURE.**

#### **NOTE:**

**If drain cock valve is plugged, release all air pressure. The valve can then be removed, cleaned, then reinstalled.**

12. After the water has been drained, close the drain valve. The air compressor can now be stored.



---

# MAINTENANCE

---

## **⚠ WARNING**

UNIT CYCLES AUTOMATICALLY WHEN POWER IS ON. WHEN DOING MAINTENANCE, YOU MAY BE EXPOSED TO VOLTAGE SOURCES, COMPRESSED AIR OR MOVING PARTS. PERSONAL INJURIES CAN OCCUR. BEFORE PERFORMING ANY MAINTENANCE OR REPAIR, UNPLUG THE COMPRESSOR AND BLEED OFF ALL AIR PRESSURE.

---

ALL MAINTENANCE AND REPAIR OPERATIONS NOT LISTED MUST BE DONE BY A QUALIFIED SERVICE TECHNICIAN.

---

### Air Filter - Inspection and Replacement

#### **⚠ WARNING**

Hot surfaces. Risk of burn. Compressor heads are exposed when filter cover is removed. Allow compressor to cool prior to servicing.

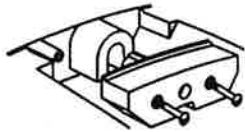

Keep the air filter clean at all times. Do not operate the compressor with the air filter removed.

A dirty air filter will not allow the compressor to operate at full capacity. Before you use the compressor, check the air filter to be sure it is clean.

### Check Valve Cleaning - Replacement

#### **⚠ WARNING**

**Risk of personal injury. Manifold assembly contains compressed air which can be hazardous. Manifold gets hot during operation.**

**Before servicing:**

- Unplug or disconnect electrical supply to compressor.
- Bleed tank of pressure.
- Allow compressor to cool.

1. Release all air pressure from air tank and unplug outfit.
2. Remove shroud. (Key Nos. 1 and 2)
3. Loosen the top and bottom nuts and remove the outlet tube. (Key Nos. 31, 33, and 34)
4. Remove the pressure release tube, fitting, and connector. (Key Nos. 25, 26 and 27)
5. Unscrew the check valve (turn counterclockwise) using a socket wrench. (Key No. 17)
6. Check that the valve disc moves freely inside the check valve and that the spring holds the disc in the upper, closed position. The check valve may be cleaned with a solvent, such as paint and varnish remover.
7. Apply a Teflon based pipe sealant to the check valve threads. Reinstall the check valve (turn clockwise).
8. Replace the pressure release tube and fitting.
9. Replace the outlet tube and tighten top and bottom nuts.
10. Replace the shroud.

### Safety Valve - Inspection

#### **⚠ WARNING**

If the safety valve does not work properly, over-pressurization may occur, causing air tank rupture or an explosion. Before starting compressor, pull the ring on the safety valve to make sure that the safety valve operates freely. If the valve is stuck or does not operate smoothly, it must be replaced with the same type of valve.

### Motor

The motor has an automatic reset thermal overload protector. If the motor overheats for any reason, the overload protector will shut off the motor. The motor must be allowed to cool down before restarting. The compressor will automatically restart after the motor cools.

If the overload protector shuts the motor off frequently, check for a possible voltage problem. Low voltage can also be suspected when:

1. The motor does not get up to full power or speed.
2. Fuses blow out when starting the motor; lights dim and remain dim when motor is started and is running.

### Storage

Before you store the air compressor, make sure you do the following:

1. Review the Maintenance and "Operating Procedures" sections and perform maintenance as necessary. Be sure to drain water from the air tank.
2. Protect the electrical cord and air hose from damage (such as being stepped on or run over). Wind them loosely around the compressor handle.

Store the air compressor in a clean and dry location.

# TROUBLESHOOTING GUIDE

## ⚠ WARNING

PERFORMING REPAIRS MAY EXPOSE VOLTAGE SOURCES, MOVING PARTS OR COMPRESSED AIR SOURCES. PERSONAL INJURY MAY OCCUR. PRIOR TO ATTEMPTING ANY REPAIRS, UNPLUG THE COMPRESSOR AND BLEED OFF TANK AIR PRESSURE.

PROBLEM	CAUSE	CORRECTION
Excessive tank pressure - safety valve pops off.	Pressure switch does not shut off motor when compressor reaches cut-out pressure.  Pressure switch cut-out too high.	Move the pressure switch lever to the "O" position. If the compressor doesn't shut off, disconnect from the electrical outlet source and return to a Sears Service Center to replace the pressure switch.  Return the compressor to Sears Service Center to check and adjust, or replace switch.
Air leaks at fittings or hose.	Tube or hose fittings are not tight enough.	Tighten fittings using teflon tape where air can be heard escaping. Check fittings with soapy water solution. <b>DO NOT OVERTIGHTEN.</b>
Air leaks at pressure switch release valve.	Defective pressure switch release valve.  Defective or dirty check valve.	Return to Sears Service Center for replacement of pressure switch.  Check to see if the pin in the bottom of the pressure release valve is stuck. If it does not move freely, return to the Service Center for replacement of pressure switch.  A defective check valve results in a constant air leak at the pressure release valve when there is pressure in the tank and the compressor is shut off. Remove and clean or replace check valve. <b>DO NOT OVERTIGHTEN.</b>
Air leaks in air tank or at air tank welds.	Defective air tank.	Air tank must be replaced. Do not repair the leak. Return compressor to Sears Service Center.  <b>⚠ WARNING</b> <b>DO NOT DRILL INTO, WELD OR OTHERWISE MODIFY AIR TANK OR IT WILL WEAKEN. THE TANK CAN RUPTURE OR EXPLODE.</b>
Air leaks between head and valve plate.	Leaking seal.	Torque head screws to 7-10 ft. lbs. If this does not stop leak, replace seal.
Pressure reading on the regulated pressure gauge drops when an accessory is used.	It is normal for some pressure drop to occur.	If there is an excessive amount of pressure drop when the accessory is used, adjust the regulator.  <b>NOTE</b> Adjust the regulated pressure under flow conditions (while accessory is being used).
Air leak from safety valve.	Possible defect in safety valve.	Operate safety valve manually by pulling on ring. If valve still leaks, it should be replaced.
Knocking noise	Defective check valve.	Remove and clean, or replace.

# TROUBLESHOOTING GUIDE (Continued)

PROBLEM	CAUSE	CORRECTION
Compressor is not supplying enough air to operate accessories.	<p>Compressor is not large enough for air requirement.</p> <p>Restricted air intake filter.</p> <p>Hole in hose.</p> <p>Check valve restricted.</p> <p>Air leaks.</p>	<p>Check the accessory air requirement. If it is higher than the SCFM or pressure supplied by your air compressor, you need a larger compressor.</p> <p>Clean or replace air intake filter. Do not operate the air compressor in any paint spray or drywall sanding area.</p> <p>Check and replace if required.</p> <p>Remove and clean, or replace.</p> <p>Tighten fittings.</p>
Motor will not run or restart.	<p>Present tank pressure exceeds pressure switch "cut-in" pressure.</p> <p>Fuse blown, circuit breaker tripped.</p> <p>Motor overload protection switch has tripped.</p> <p>Possible defective motor or capacitor.</p> <p>Paint spray on internal motor parts.</p> <p>Check valve stuck open, putting pressure on head.</p> <p>Pressure release valve on pressure switch has not unloaded head pressure.</p> <p>Broken exhaust valve.</p>	<p>Motor will start automatically when tank pressure drops below "cut-in" pressure of pressure switch.</p> <ol style="list-style-type: none"> <li>1. Check fuse box for blown fuse and replace, if necessary. Reset circuit breaker. Do not use a fuse or circuit breaker with higher rating than that specified for your particular branch circuit.</li> <li>2. Check for proper fuse; only Time Delay fuses are acceptable.</li> <li>3. Check for low voltage conditions and/or proper extension cord.</li> <li>4. Disconnect the other electrical appliances from circuit or operate the compressor on its own branch circuit.</li> <li>5. Check for loose electrical connections.</li> </ol> <p>Let motor cool off and overload switch will automatically reset.</p> <p>Return to Sears Service Center for inspection or replacement, if necessary.</p> <p>Have compressor checked at Sears Service Center. Do not operate the compressor in the paint spray area. See flammable vapor warning.</p> <p>Remove and clean, or replace the check valve.</p> <p>Bleed the line by pushing the lever on the pressure switch to the "O" position; if the valve does not open, replace it.</p> <p>Inspect and replace if necessary.</p>
Regulator knob continuous air leak. Regulator will not shut off at air outlet.	Dirty or damaged regulator internal parts.	Replace regulator.

# AIR COMPRESSOR DIAGRAM

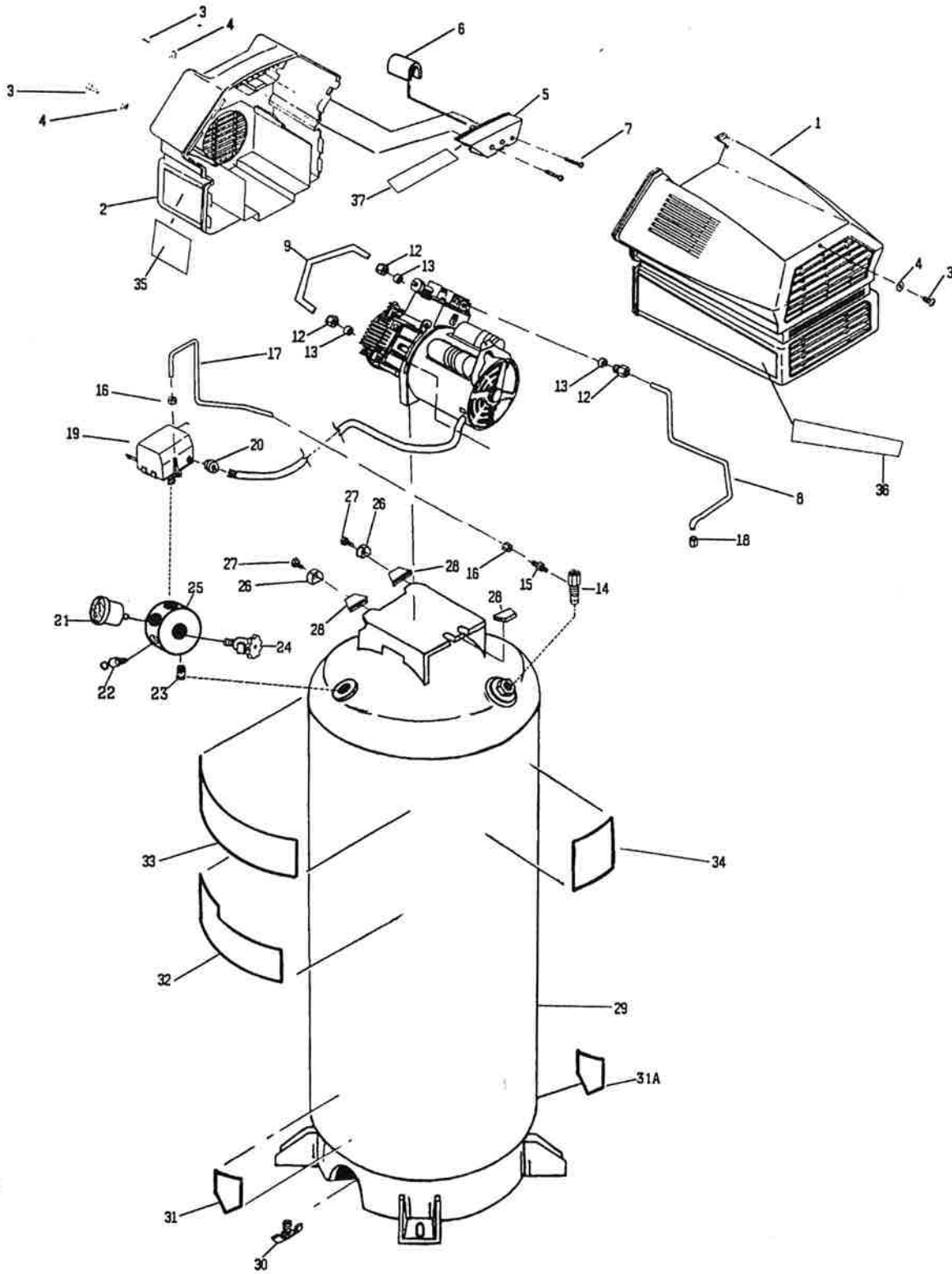

# PARTS LIST

<u>KEY NO.</u>	<u>PART NUMBER</u>	<u>DESCRIPTION</u>
1	ACG-61-1	Shroud, Rear
2	ACG-14	Shroud, Front
3	SSF-553	Screw, #10-24x9/16 Pan HD (3 used: Torque 33-38 in.-lbs.)
4	SSG-3102	O-ring (3 used)
5	ACG-13	Cover, Intake Muffler
6	ACG-12	Filter, Intake
7	SSF-554	Screw, #10-14 x 2 1/2 Pan HD (2 used)
8	AC-0242	Tube, Outlet 60 Gal
9	AC-0099	Tube, Outlet 60 Gal
12	SSP-7821-1	Nut, Compression for .50" (3 used)
13	SSG-3105	O-Ring (3 used)
14	CAC-4290-3	Check Valve
15	SS-8553	Connector Body
16	SSF-7811	Nut-Sleeve Assembly 1/4" (2 used)
17	AC-0215	Pressure Relief Tube
18	SSP-7813	Nut-Sleeve Assembly 3/8"
19	CAC-4221-2	Pressure Switch 100/125
20	SSW-7367	Strain Relief Bushing
21	GA-360	Gauge
22	97503734	Safety Valve
23	SS-2072-1	Nipple .375 NPT
24	SSV-812	Valve, Truck (Globe)
25	AC-0217	Manifold
26	ACG-18	Saddle Mount Cup (2 used)
27	SSF-927	Screw, 1/4" - 20 x .1 1/8" (2 used: Torque 108-144 in.-lbs.)
28	ACG-19	Isolator (3 used)
29	TA-4367	Tank (60 Gal.)
30	SS-2707	Drain Valve
31	LA-1978-1	Label - Drain Tank
31A	LA-2633	Label- Drain Tank (French)
32	LA-1811-1	Label- Sears Craftsman
33	LA-2642	Label - Warning
34	CL-741	Label - Spec/Maint.
35	LA-2554	Label - Performance Sears
36	LA-2556	Label - 6HP 60 Gal
37	LA-2616	Label - Air Filer Cover

# COMPRESSOR PUMP DIAGRAM

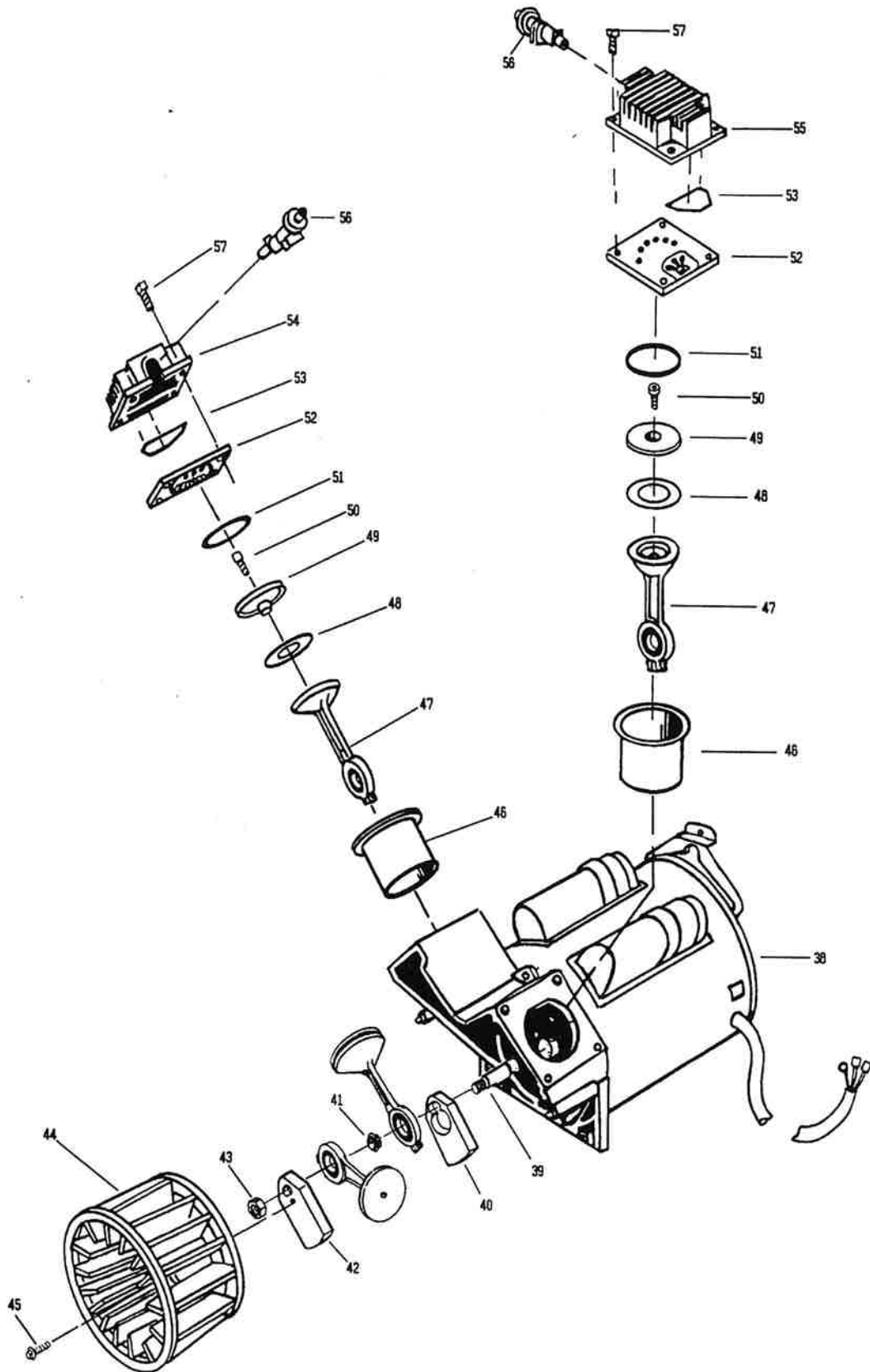

---

# PARTS LIST

---

<u>KEY NO.</u>	<u>PART NUMBER</u>	<u>DESCRIPTION</u>
38	MO-3024	Motor
39	ACG-8	Pin, Eccentric
40	ACG-6	Counter Balance, Inner
41	ACG-9	Washer
42	ACG-7	Counter Balance, Outer
43	ACG-23	Nut (Torque 85-90 ft.-lbs.)
44	ACG-22	Fan
45	39124607	Screw, Self Tap 1/4 x 5/8 (Torque 130-145 in.-lbs.)
X•46	CAC-249-3	Sleeve, Cylinder (2 used)
•47	ACG-65	Connecting Rod (2 used)
X•48	DAC-308	Compression Ring (2 used)
•49	ACG-29	Connecting Rod Cap (2 used)
X•50	SSF-3158-1	Screw, 10-24 x .75 (2 used)
•51	SSG-8156	O-ring (2 used)
52	AC-0032	Valve Plate Assembly (2 used)
•53	ACG-45	O-ring, Perm Lube Head (2 used)
54	AC-0038	Head, Left
55	AC-0037	Head, Right
56	ACG-11	Muffler, Intake (2 used)
57	SSF-927	Screw, 1/4" - 20 x 1 1/8" (8 used: Torque 7-10 ft.-lbs.)

NOT ILLUSTRATED  
MGP-726600

Owners Manual

- x Key No's. 46, 48 & 50 can be purchased in K-0058 Compression Ring Kit.
- Key No's. 46 through 51 and 53 can be purchased in K-5081 Connecting Rod Kit. Quantities are one of each item.

---

# SERVICE NOTES

---



---

# SERVICE NOTES

---

# **SEARS**

## **CRAFTSMAN**

### **MODEL NO.**

### **SERVICE**

## **HOW TO ORDER REPAIR PARTS**

## **OWNERS MANUAL FOR**

### **• TWIN-V OILFREE • TANK MOUNTED AIR COMPRESSOR**

The model number of your Sears Air Compressor can be found on the maintenance label on the top of the shroud or on the bar code label on the rear of the air tank.

#### **SERVICE AND REPAIR PARTS CALL 1-800-665-4455\***

Keep this number handy should you require a service call or need to order repair parts.

If ordering parts make sure you have the name, make and model no. of the merchandise and the name and number of the part you wish to order.

**\*If calling locally, please use one of the following numbers:**

Regina - 566-5124	Montreal - 333-5740
Toronto - 744-4900	Halifax - 454-2444
Kitchener - 894-7590	Ottawa - 738-4440
Vancouver - 420-8211	

**WHEN ORDERING REPAIR PARTS, ALWAYS GIVE THE FOLLOWING INFORMATION:**

- PART NUMBER
- PART DESCRIPTION
- MODEL NUMBER
- NAME OF ITEM

All parts listed may be ordered from any Sears Service Center and most Sears stores.

If the parts you need are not stocked locally, your order will be electronically transmitted to a Sears Repair Parts Distribution Center for handling.

## Free Manuals Download Website

<http://myh66.com>

<http://usermanuals.us>

<http://www.somanuals.com>

<http://www.4manuals.cc>

<http://www.manual-lib.com>

<http://www.404manual.com>

<http://www.luxmanual.com>

<http://aubethermostatmanual.com>

Golf course search by state

<http://golfingnear.com>

Email search by domain

<http://emailbydomain.com>

Auto manuals search

<http://auto.somanuals.com>

TV manuals search

<http://tv.somanuals.com>