

ILLUSTRATED PARTS LIST

MODEL NUMBER 12527SB

PRODUCT NUMBER 961 93 00-56

MFG. ID. NUMBER 96193005600

REPAIR PARTS

AUGER HOUSING / IMPELLER ASSEMBLY

SNOW THROWER - MODEL NO. 12527SB (96193005600), PRODUCT NO. 961 93 00-56

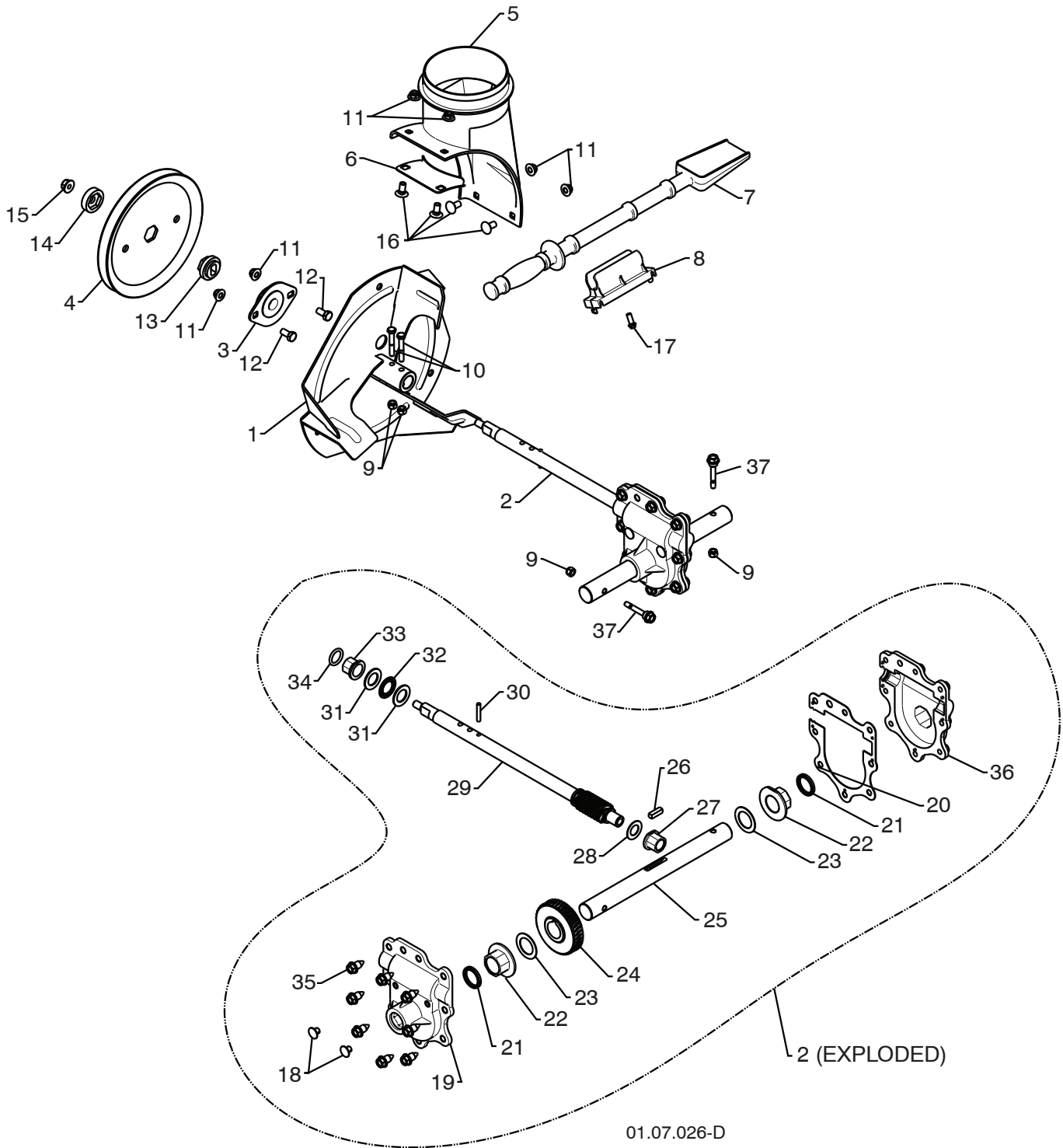

NOTE: All component dimensions given in U.S. inches. 1 inch = 25.4 mm
IMPORTANT: Use only Original Equipment Manufacturer (O.E.M.) replacement parts.
Failure to do so could be hazardous, damage your snow thrower and void your warranty.

REPAIR PARTS**AUGER HOUSING / IMPELLER ASSEMBLY****SNOW THROWER - MODEL NO. 12527SB (96193005600), PRODUCT NO. 961 93 00-56**

KEY NO.	PART NO.	DESCRIPTION
1	532 43 57-75	IMPELLER
2	532 42 71-48	GEARBOX ASSEMBLY
3	532 18 89-09	BEARING
4	532 42 71-46	IMPELLER PULLEY
5	532 17 53-22	DISCHARGE BASE
6	532 18 40-95	CORNER BRACKET
7	532 19 21-99	CLEAN OUT TOOL
8	532 40 54-00	TOOL CLIP
9	873 80 04-00	NUT 1/4-20
10	874 78 04-26	SCREW 1/4-20 X .625
11	532 42 79-42	NUT 5/16-18
12	532 16 31-83	SCREW 5/16-18 X .625
13	532 42 71-45	IMPELLER HUB
14	532 42 71-54	IMPELLER SLEEVE
15	873 90 06-00	NUT 3/8-16
16	532 18 03-55	CARRIAGE BOLT
17	532 19 41-89	SCREW 13-16 X .625
18	532 40 77-60	PLUG
19	532 42 73-02	GEARBOX COVER RH
20	532 42 73-45	GASKET
21	532 40 77-70	SEAL
22	532 40 77-62	BEARING
23	532 17 46-97	THRUST WASHER 1.00
24	532 40 77-63	WORM GEAR
25	532 40 77-64	AUGER SHAFT
26	532 18 92-82	SQUARE KEY
27	532 40 77-58	BEARING
28	532 17 46-83	THRUST WASHER
29	532 42 71-47	IMPELLER SHAFT
30	532 18 42-05	ROLL PIN
31	532 17 46-81	THRUST WASHER
32	532 17 46-84	THRUST BEARING
33	532 40 77-69	BEARING
34	532 40 77-68	O-RING
35	532 40 77-67	SCREW 5/16-18 X .750
36	532 42 73-17	GEARBOX COVER LH
37	532 19 20-90	SHEAR BOLT

NOTE: All component dimensions given in U.S. inches. 1 inch = 25.4 mm

IMPORTANT: Use only Original Equipment Manufacturer (O.E.M.) replacement parts. Failure to do so could be hazardous, damage your snow thrower and void your warranty.

REPAIR PARTS

AUGER HOUSING / IMPELLER ASSEMBLY

SNOW THROWER - MODEL NO. 12527SB (96193005600), PRODUCT NO. 961 93 00-56

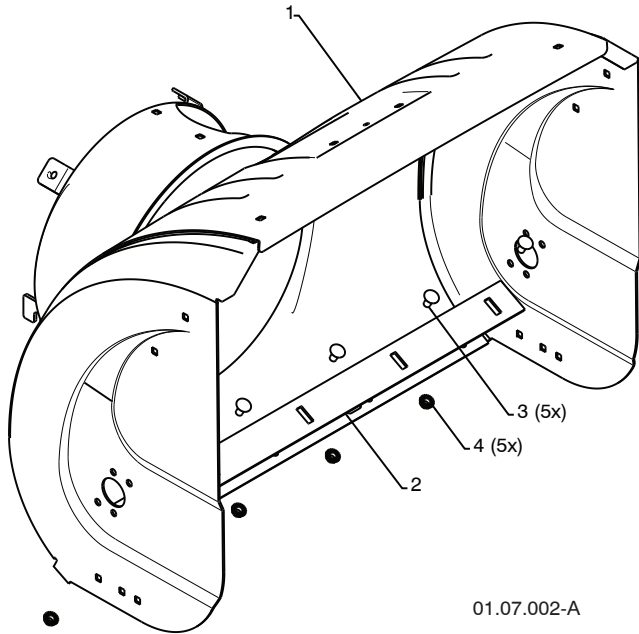

01.07.002-A

KEY NO.	PART NO.	DESCRIPTION
1	532 40 77-39	AUGER HOUSING 27
2	532 43 58-53	SCRAPER BAR
3	872 27 05-05	CARRIAGE BOLT 5/16-18 X .625
4	532 15 53-77	NUT 5/16-18

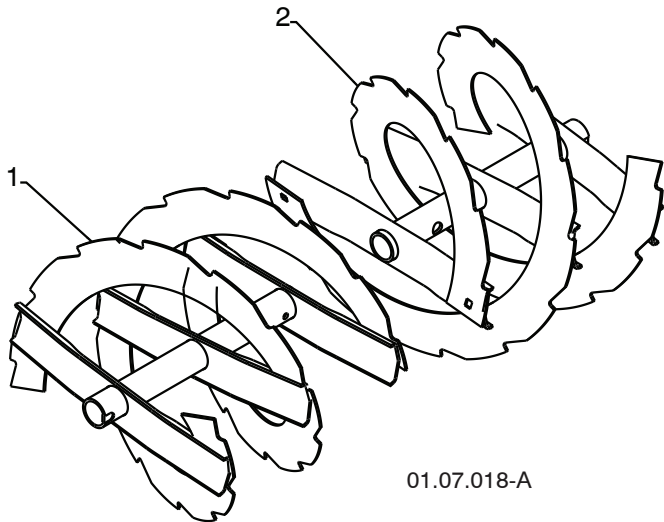

01.07.018-A

KEY NO.	PART NO.	DESCRIPTION
1	532 43 62-55	AUGER 27 LH
2	532 43 62-56	AUGER 27 RH

NOTE: All component dimensions given in U.S. inches. 1 inch = 25.4 mm
IMPORTANT: Use only Original Equipment Manufacturer (O.E.M.) replacement parts. Failure to do so could be hazardous, damage your snow thrower and void your warranty.

REPAIR PARTS

AUGER HOUSING / IMPELLER ASSEMBLY

SNOW THROWER - MODEL NO. 12527SB (96193005600), PRODUCT NO. 961 93 00-56

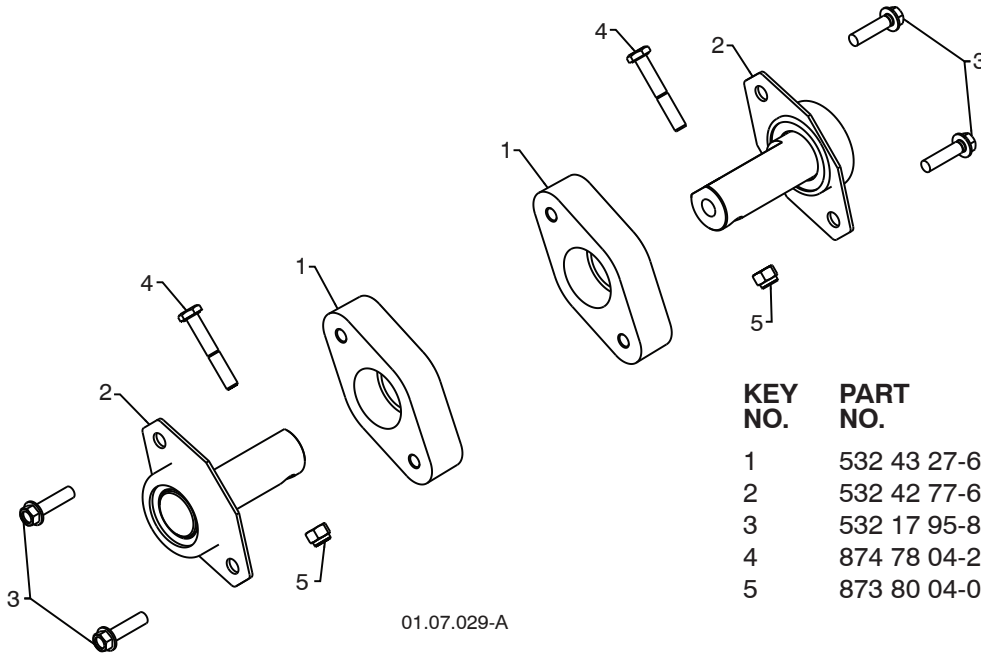

KEY NO.	PART NO.	DESCRIPTION
1	532 43 27-65	PLASTIC RETAINER
2	532 42 77-62	AUGER BALL BEARING
3	532 17 95-82	SCREW 5/16-18 X 1.00
4	874 78 04-26	SCREW 1/4-20 X .625
5	873 80 04-00	NUT 1/4-20

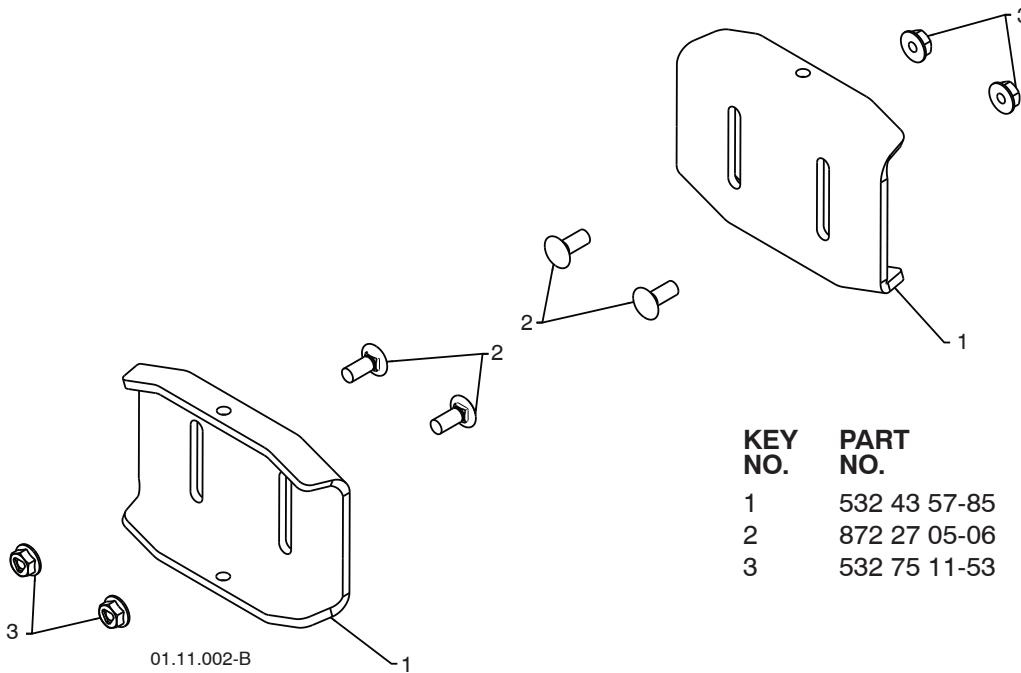

KEY NO.	PART NO.	DESCRIPTION
1	532 43 57-85	SKID PLATE
2	872 27 05-06	CARRIAGE BOLT 5/16-18 X .750
3	532 75 11-53	NUT 5/16-18

NOTE: All component dimensions given in U.S. inches. 1 inch = 25.4 mm
IMPORTANT: Use only Original Equipment Manufacturer (O.E.M.) replacement parts.
 Failure to do so could be hazardous, damage your snow thrower and void your warranty.

REPAIR PARTS

CONTROL PANEL / DISCHARGE CHUTE

SNOW THROWER - MODEL NO. 12527SB (96193005600), PRODUCT NO. 961 93 00-56

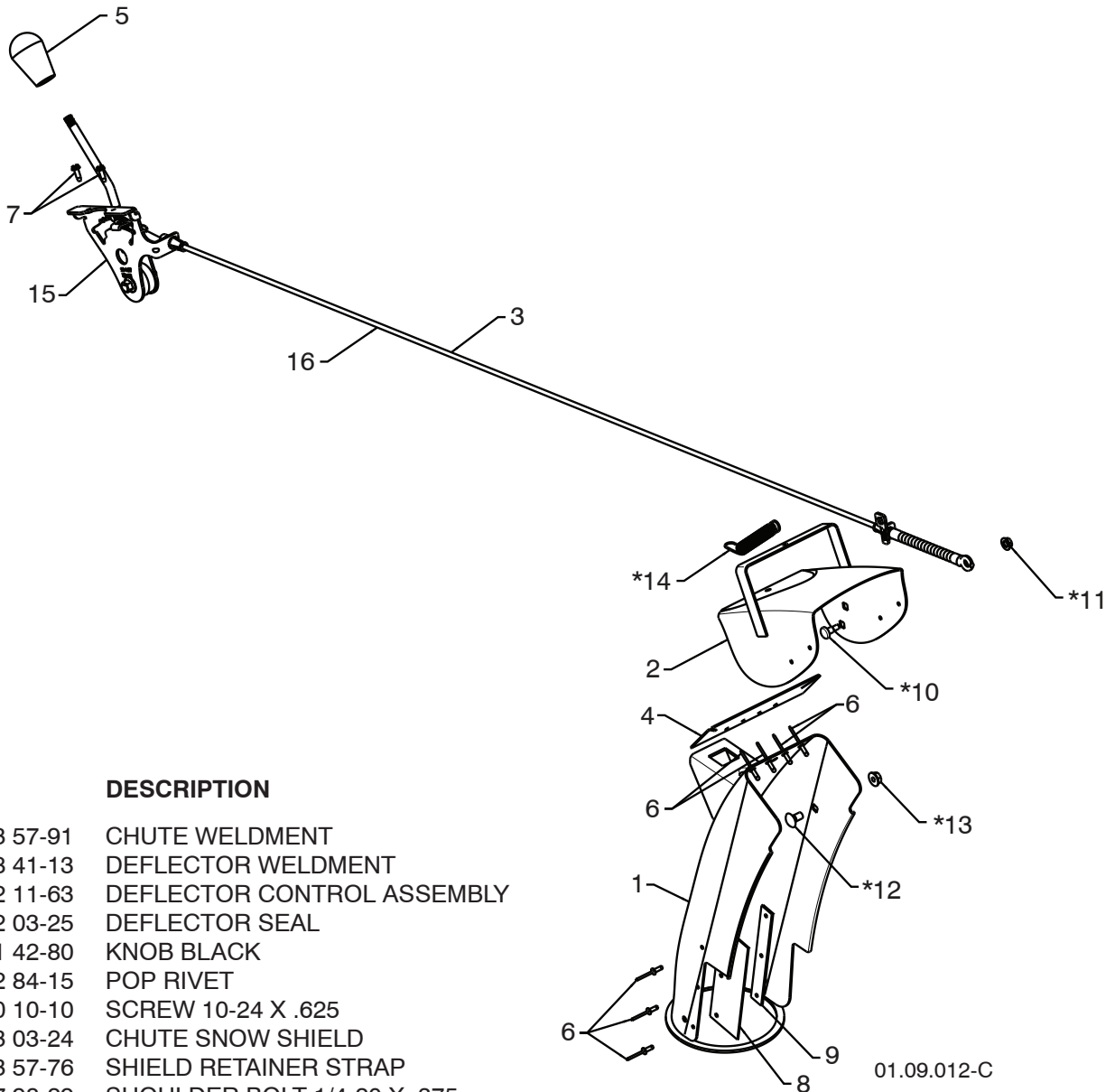

KEY NO.	PART NO.	DESCRIPTION
1	532 43 57-91	CHUTE WELDMENT
2	532 18 41-13	DEFLECTOR WELDMENT
3	532 42 11-63	DEFLECTOR CONTROL ASSEMBLY
4	532 42 03-25	DEFLECTOR SEAL
5	532 41 42-80	KNOB BLACK
6	532 12 84-15	POP RIVET
7	817 50 10-10	SCREW 10-24 X .625
8	532 43 03-24	CHUTE SNOW SHIELD
9	532 43 57-76	SHIELD RETAINER STRAP
*10	532 17 98-29	SHOULDER BOLT 1/4-20 X .375
*11	532 19 17-30	NUT 1/4-20
*12	872 25 05-05	CARRIAGE BOLT 3/8-16 X .625
*13	532 75 11-53	NUT 5/16-18
*14	532 18 45-05	DEFLECTOR SPRING
15	532 42 06-79	(SERVICE PART) DEFLECTOR CONTROL
16	532 42 11-64	(SERVICE PART) DEFLECTOR CABLE GRAY

NOTE:

1. ALL ITEMS INDICATED WITH AN * ARE PROVIDED IN THE BAG OF ITEMS SHIPPED LOOSE WITH PRODUCT.
2. ITEMS 15 AND 16 ARE SERVICE PART NUMBERS TO ALLOW PURCHASE OF INDIVIDUAL ITEMS IF NECESSARY.

NOTE: All component dimensions given in U.S. inches. 1 inch = 25.4 mm
IMPORTANT: Use only Original Equipment Manufacturer (O.E.M.) replacement parts.
 Failure to do so could be hazardous, damage your snow thrower and void your warranty.

REPAIR PARTS

CONTROL PANEL / DISCHARGE CHUTE

SNOW THROWER - MODEL NO. 12527SB (96193005600), PRODUCT NO. 961 93 00-56

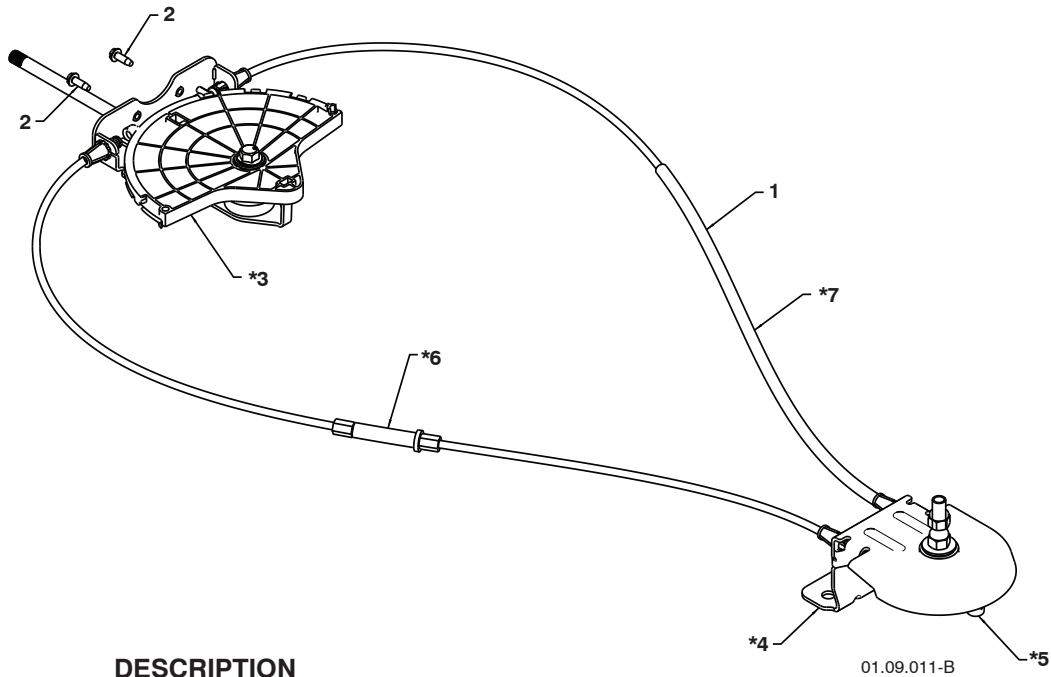

KEY NO.	PART NO.	DESCRIPTION
1	532 42 82-74	LEVER/CABLE ROTATOR ASSEMBLY
2	817 50 10-10	SCREW 10-24 X .625
*3	532 42 06-78	ROTATOR HEAD
*4	532 42 28-23	ROTATOR PIVOT BRACKET
*5	532 42 06-75	PULLEY PIVOT
*6	532 42 82-75	CABLE ASSEMBLY ADJUSTABLE GRAY
*7	532 42 83-11	CABLE ASSEMBLY HEAT SHIELD GRAY

NOTES:

1. ITEMS INDICATED WITH AN * ARE LISTED AS REFERENCE FOR SERVICE PARTS ONLY.

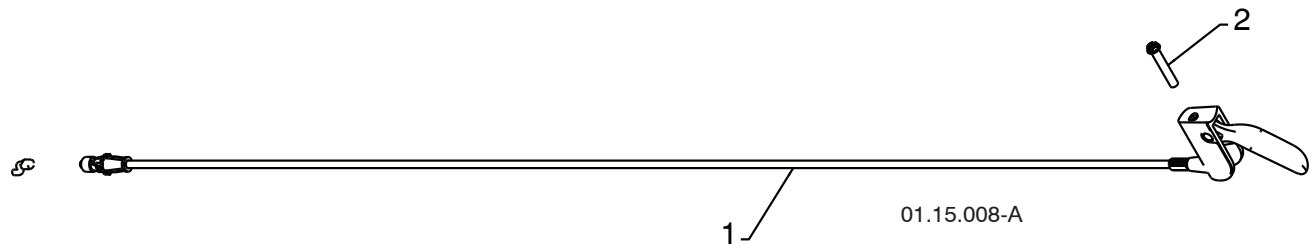

KEY NO.	PART NO.	DESCRIPTION
1	532 42 12-31	STEER CABLE
2	874 04 10-24	SCREW 10-24 X 1.50

NOTE: All component dimensions given in U.S. inches. 1 inch = 25.4 mm
IMPORTANT: Use only Original Equipment Manufacturer (O.E.M.) replacement parts. Failure to do so could be hazardous, damage your snow thrower and void your warranty.

REPAIR PARTS

HANDLES

SNOW THROWER - MODEL NO. 12527SB (96193005600), PRODUCT NO. 961 93 00-56

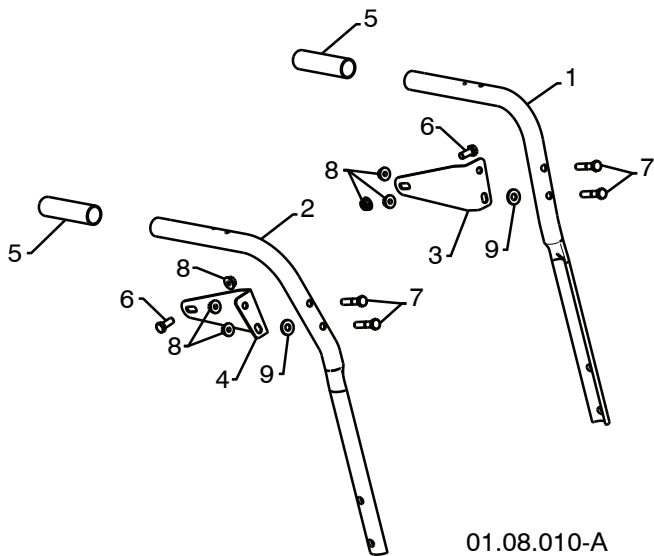

KEY NO.	PART NO.	DESCRIPTION
1	532 42 17-08	PLOW HANDLE LH
2	532 42 17-09	PLOW HANDLE RH
3	532 42 91-48	PANEL BRACKET LH
4	532 42 91-49	PANEL BRACKET RH
5	532 19 95-13	HANDLE GRIP
6	874 78 05-12	SCREW 5/16-18 X .750
7	874 78 05-24	SCREW 5/16-18 X 1.50
8	532 75 11-53	NUT 5/16-18
9	532 15 54-15	WASHER

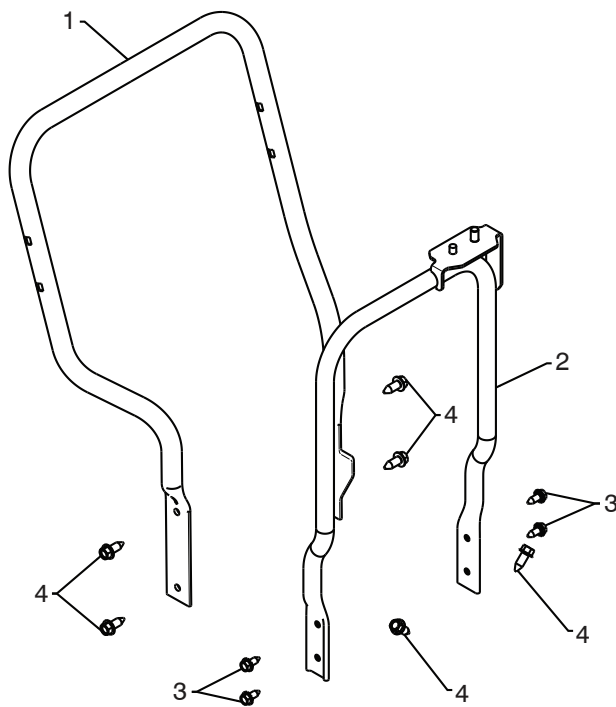

KEY NO.	PART NO.	DESCRIPTION
1	532 42 17-05	LOWER TUBE GRAY
2	532 43 58-03	PIVOT SUPPORT
3	532 42 88-67	BOLT 5/16-18 X .750
4	817 00 06-16	SCREW 3/8-16 X 1.00

NOTE: All component dimensions given in U.S. inches. 1 inch = 25.4 mm
IMPORTANT: Use only Original Equipment Manufacturer (O.E.M.) replacement parts. Failure to do so could be hazardous, damage your snow thrower and void your warranty.

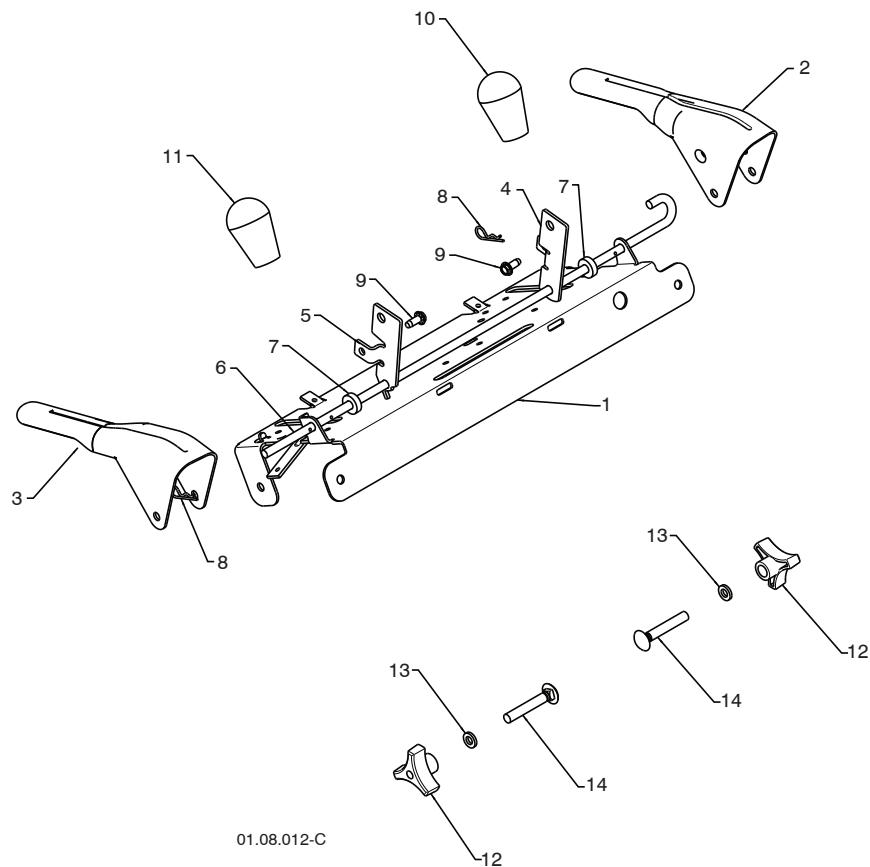

01.08.012-C

KEY NO.	PART NO.	DESCRIPTION
1	532 43 58-04	CONTROL PANEL
2	532 42 91-50	CONTROL LEVER LH
3	532 42 91-51	CONTROL LEVER RH
4	532 42 90-97	TRACTION ROD ARM
5	532 42 90-98	IMPELLER ROD ARM
6	532 41 26-77	INTERLOCK ROD
7	532 42 16-13	SPACER
8	532 16 96-75	RETAINER
9	817 06 04-10	SCREW 1/4-20 X .62
10	532 41 42-80	KNOB BLACK
11	532 41 42-81	KNOB RED
12	532 17 88-99	HANDLE KNOB
13	819 13 13-16	WASHER 3/8
14	872 12 06-18	CARRIAGE BOLT 3/8-16 X 2.25

NOTE: All component dimensions given in U.S. inches. 1 inch = 25.4 mm
IMPORTANT: Use only Original Equipment Manufacturer (O.E.M.) replacement parts. Failure to do so could be hazardous, damage your snow thrower and void your warranty.

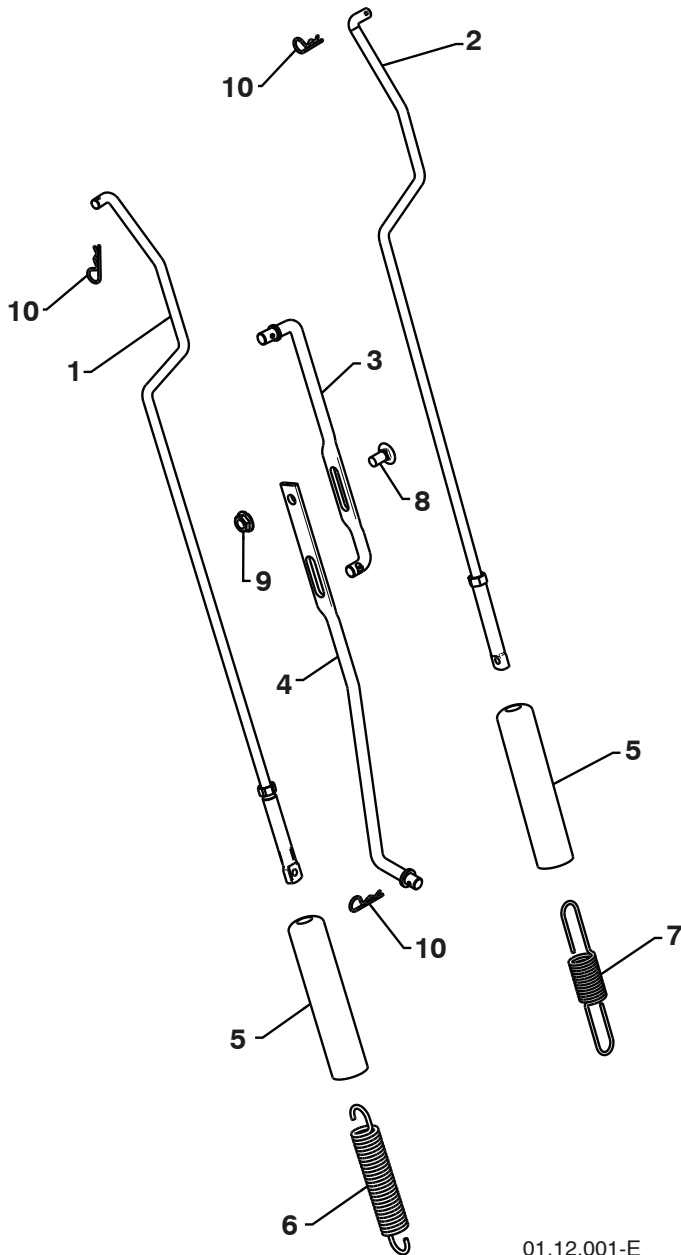

KEY NO.	PART NO.	DESCRIPTION
1	532 18 04-80	IMPELLER ROD ASSEMBLY
2	532 40 57-40	TRACTION ROD ASSEMBLY
3	532 18 04-45	SHIFTER ROD TOP
4	532 18 77-16	SHIFTER ROD BOTTOM
5	532 18 04-47	SPRING SLEEVE
6	532 17 86-69	IMPELLER SPRING
7	532 18 09-26	TRACTION SPRING
8	872 27 05-05	CARRIAGE BOLT 5/16-18 X .75
9	532 15 53-77	NUT 5/16-18
10	532 16 96-75	RETAINER

01.12.001-E

NOTE: All component dimensions given in U.S. inches. 1 inch = 25.4 mm
IMPORTANT: Use only Original Equipment Manufacturer (O.E.M.) replacement parts.
 Failure to do so could be hazardous, damage your snow thrower and void your warranty.

REPAIR PARTS

HANDLES

SNOW THROWER - MODEL NO. 12527SB (96193005600), PRODUCT NO. 961 93 00-56

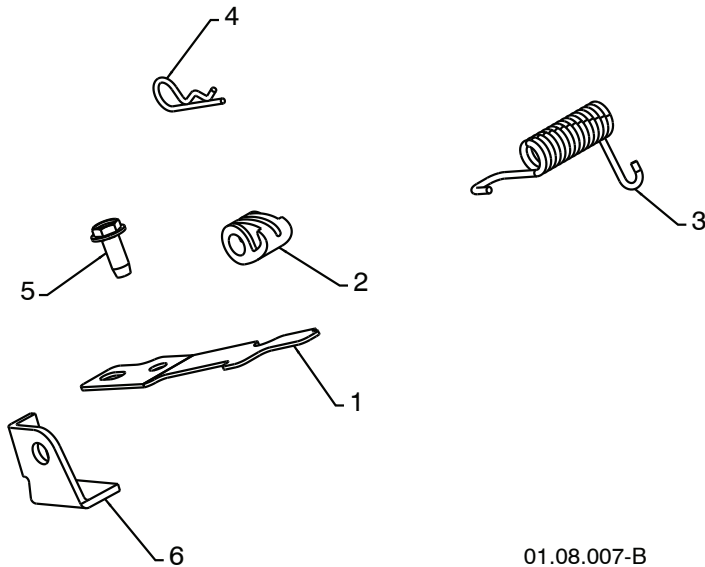

KEY NO.	PART NO.	DESCRIPTION
1	532 43 58-06	INTERLOCK SPRING
2	532 41 45-72	INTERLOCK CAM
3	532 17 88-31	TORSION SPRING
4	532 16 96-75	RETAINER
5	817 06 04-10	SCREW 1/4-20 X .625
6	532 43 58-05	INTERLOCK STOP

01.08.007-B

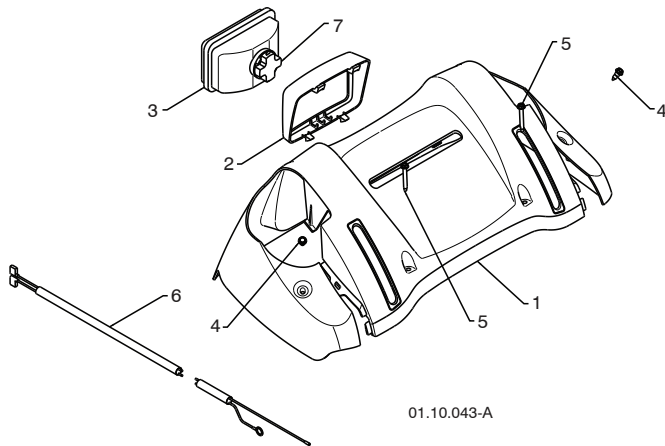

KEY NO.	PART NO.	DESCRIPTION
1	532 42 13-82	CONSOLE PANEL GRAY
2	532 42 14-48	HEADLIGHT BEZEL GRAY
3	532 18 09-27	FLOOD HEADLIGHT
4	532 18 44-71	SCREW 10-24 X .625
5	532 17 52-62	SCREW 10-24 X 1.25
6	532 17 87-70	WIRE HARNESS
7	532 18 37-84	BULB

01.10.043-A

NOTE: All component dimensions given in U.S. inches. 1 inch = 25.4 mm
IMPORTANT: Use only Original Equipment Manufacturer (O.E.M.) replacement parts.
 Failure to do so could be hazardous, damage your snow thrower and void your warranty.

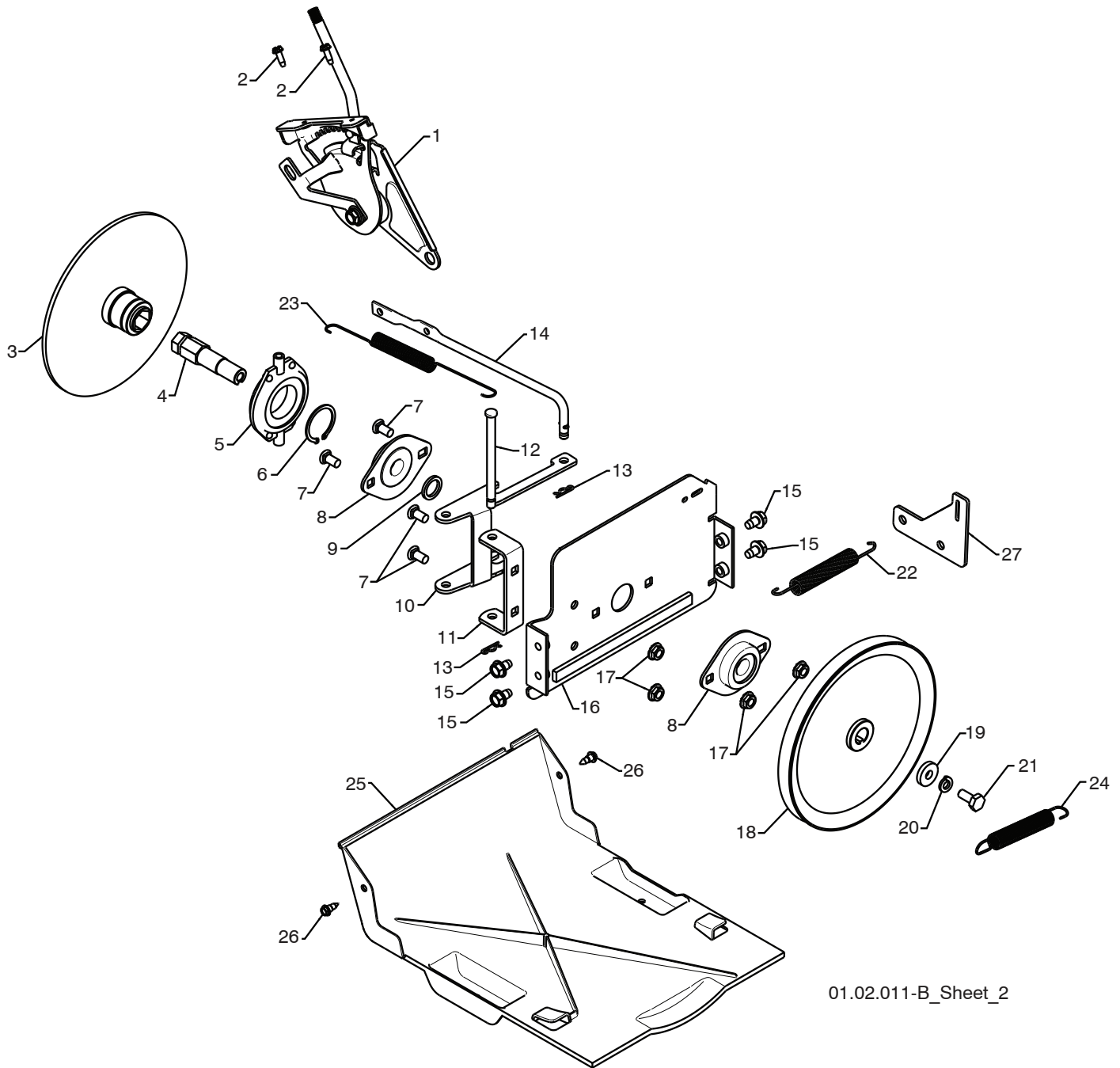

01.02.011-B_Sheet_2

NOTE: All component dimensions given in U.S. inches. 1 inch = 25.4 mm
IMPORTANT: Use only Original Equipment Manufacturer (O.E.M.) replacement parts.
Failure to do so could be hazardous, damage your snow thrower and void your warranty.

REPAIR PARTS**DRIVE****SNOW THROWER - MODEL NO. 12527SB (96193005600), PRODUCT NO. 961 93 00-56**

KEY NO.	PART NO.	DESCRIPTION
1	532 19 88-75	SPEED SELECTOR HEAD ASSEMBLY
2	817 50 10-10	SCREW 10-24 X .625
3	532 19 77-63	DRIVE PLATE WELDMENT
4	532 19 77-64	HEX SHAFT
5	532 17 53-44	TRUNNION BEARING ASSEMBLY
6	812 00 00-12	RETAINER
7	872 27 05-05	CARRIAGE BOLT 5/16-18 X .625
8	532 18 89-09	FLANGE BEARING
9	532 18 25-04	SPACER
10	532 43 57-87	LEVER SHIFTER PLATE
11	532 43 57-84	SHIFTER SUPPORT BRACKET
12	532 17 86-95	PIN
13	532 08 51-79	RETAINER
14	532 40 33-00	CLUTCH ROD
15	817 49 05-08	BOLT 5/16-18 X .500
16	532 43 57-83	DRIVE MOUNT PLATE
17	532 15 53-77	NUT 5/16-18
18	532 19 10-80	TRACTION PULLEY
19	819 11 15-07	WASHER
20	810 04 05-00	LOCKWASHER 5/16
21	874 95 05-12	SCREW 5/16-18 X .750
22	532 41 45-57	TRACTION SPRING
23	532 17 90-95	RETURN SPRING
24	532 17 88-28	BRAKE SPRING
25	532 41 08-77	BOTTOM PAN
26	532 18 44-71	SCREW 10-24 X .625
27	532 43 57-72	TRACTION SPRING BRACKET

NOTE: All component dimensions given in U.S. inches. 1 inch = 25.4 mm

IMPORTANT: Use only Original Equipment Manufacturer (O.E.M.) replacement parts. Failure to do so could be hazardous, damage your snow thrower and void your warranty.

SNOW THROWER - MODEL NO. 12527SB (96193005600), PRODUCT NO. 961 93 00-56

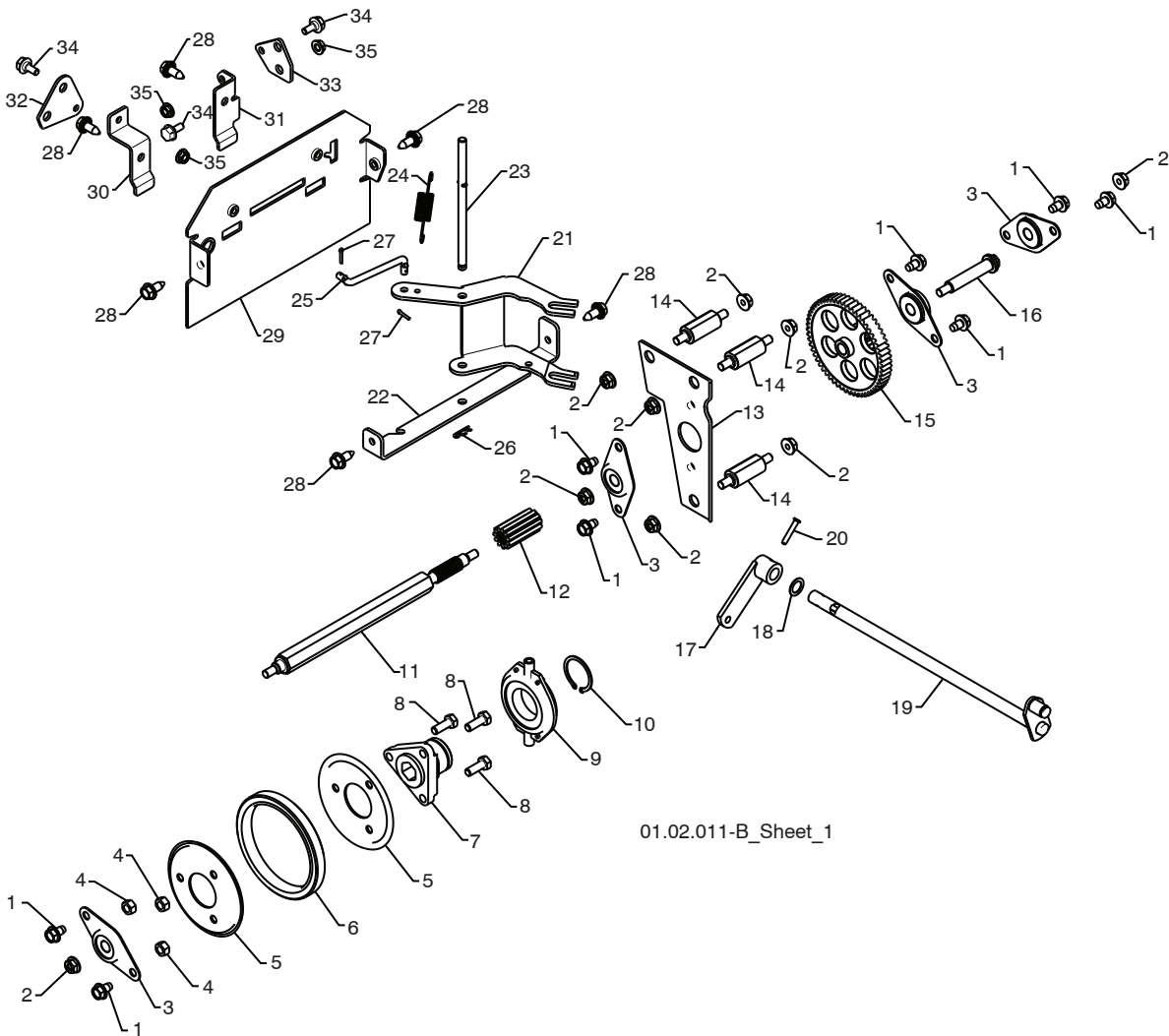

01.02.011-B_Sheet_1

KEY NO.	PART NO.	DESCRIPTION	KEY NO.	PART NO.	DESCRIPTION
1	817 49 05-08	BOLT 5/16-18 X .500	19	532 42 75-42	CONTROL SHAFT ASSEMBLY
2	532 75 11-53	NUT 5/16-18	20	532 19 85-80	CLEVIS PIN
3	532 18 00-17	FLANGE BEARING	21	532 43 57-92	SHIFTER LEVER
4	873 93 05-00	NUT 5/16-18	22	532 43 57-93	PIVOT BRACKET
5	532 43 57-89	RUBBER WHEEL PLATE	23	532 17 88-07	PIVOT PIN
6	532 17 98-31	RUBBER WHEEL RING	24	532 18 01-35	SPRING
7	532 17 86-13	RUBBER WHEEL HUB	25	532 18 71-01	SHIFTER LINK
8	874 76 05-14	BOLT 5/16-18 X .875	26	532 08 51-79	RETAINER
9	532 17 53-44	TRUNNION BEARING ASSEMBLY	27	532 70 02-79	CLIP
10	812 00 00-12	RETAINER	28	532 42 88-67	SCREW 5/16-18 x .750
11	532 18 00-66	HEX SHAFT	29	532 41 69-21	REAR PLATE
12	532 18 00-65	PINION GEAR	30	532 43 57-97	SHIFTER PLATE BRACKET
13	532 43 57-90	AUXILIARY PLATE	31	532 43 57-96	CLUTCH PLATE BRACKET
14	532 17 92-70	SPACER PLATE	32	532 43 58-00	SHIFTER PLATE
15	532 18 00-82	INTERMEDIATE GEAR	33	532 43 57-99	CLUTCH PLATE
16	532 18 01-34	AUXILIARY SHAFT	34	532 40 28-81	SHOULDER BOLT 3/8 x .25
17	532 40 54-85	CONTROL ARM	35	532 19 17-30	NUT 1/4-20
18	532 05 70-79	WASHER			

NOTE: All component dimensions given in U.S. inches. 1 inch = 25.4 mm

IMPORTANT: Use only Original Equipment Manufacturer (O.E.M.) replacement parts. Failure to do so could be hazardous, damage your snow thrower and void your warranty.

REPAIR PARTS

DRIVE

SNOW THROWER - MODEL NO. 12527SB (96193005600), PRODUCT NO. 961 93 00-56

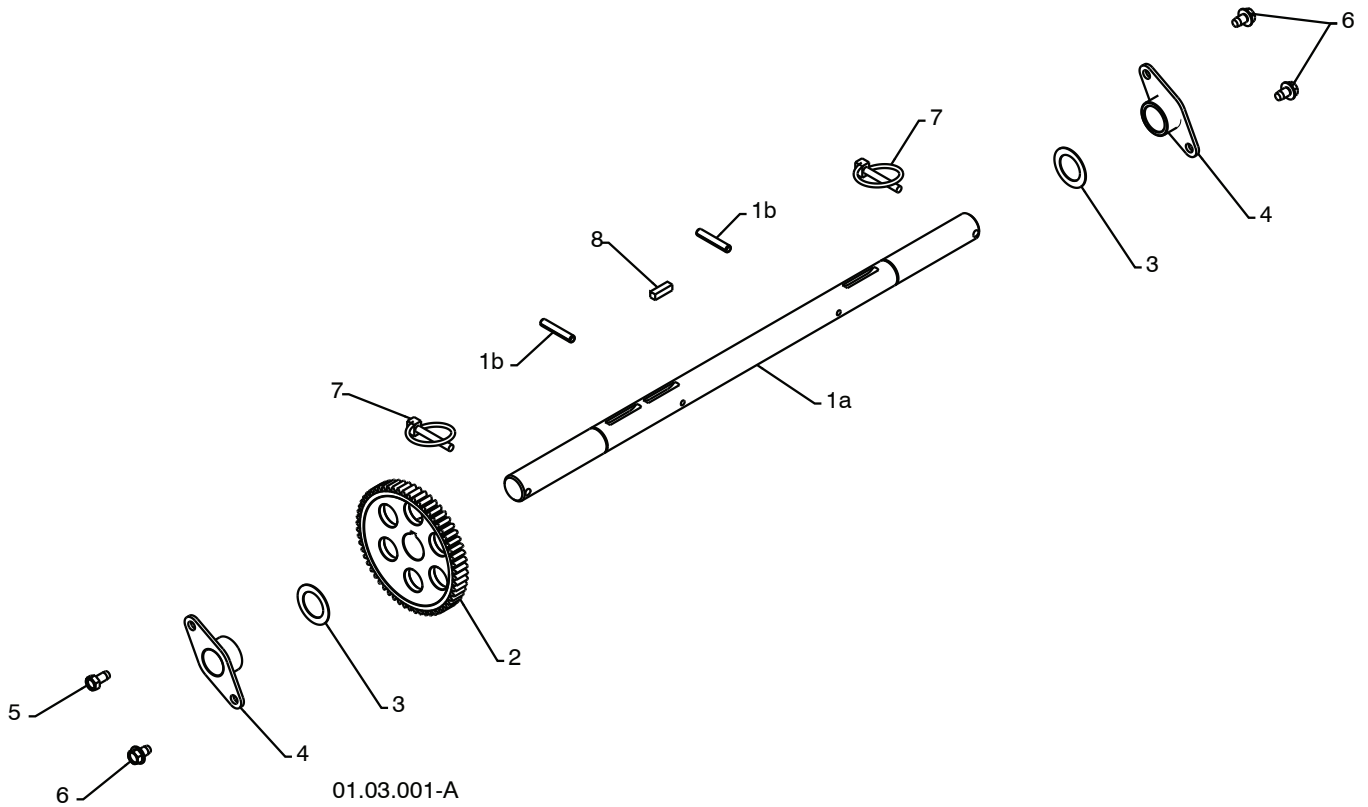

KEY NO.	PART NO.	DESCRIPTION
1	532 40 49-23	(assy of 1a,1b) AXLE ASSEMBLY
1a	532 40 43-07	AXLE SHAFT
1b	532 18 42-06	ROLL PIN 3/16
2	532 18 00-81	GEAR
3	532 17 46-97	THRUST WASHER
4	532 17 98-30	AXLE BEARING
5	532 14 63-15	SCREW 5/16-18 X .625
6	817 49 05-08	BOLT 5/16-18 X .500
7	532 15 54-43	CLIK PIN
8	532 18 92-82	SQUARE KEY

NOTE: All component dimensions given in U.S. inches. 1 inch = 25.4 mm
IMPORTANT: Use only Original Equipment Manufacturer (O.E.M.) replacement parts.
 Failure to do so could be hazardous, damage your snow thrower and void your warranty.

REPAIR PARTS

CHASSIS / ENGINE / PULLEYS

SNOW THROWER - MODEL NO. 12527SB (96193005600), PRODUCT NO. 961 93 00-56

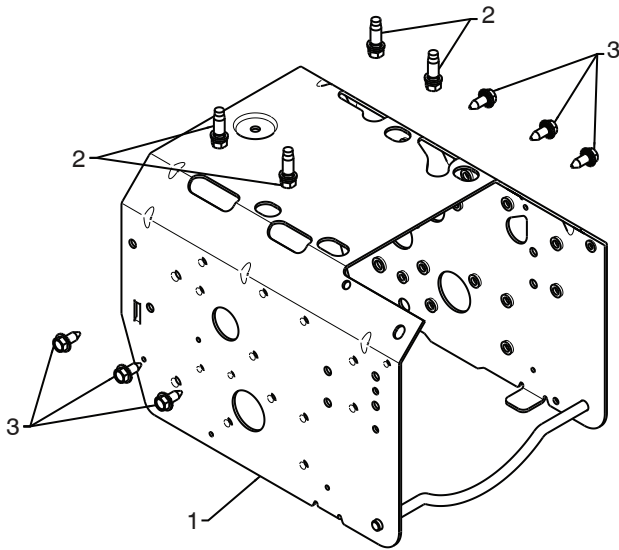

01.00.033-A

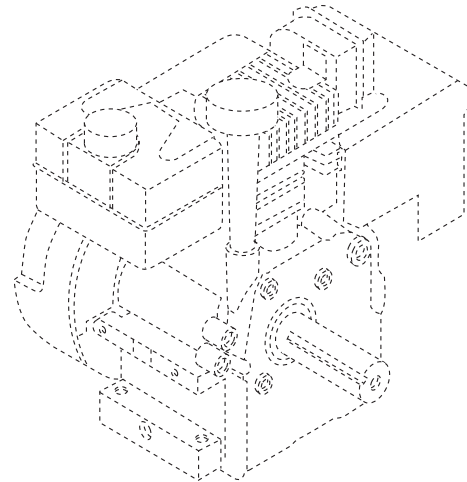

KEY NO.	PART NO.	DESCRIPTION
--	532 42 81-73	COMPLETE LCT ENGINE
1	532 42 92-03	FRAME
2	532 15 04-06	BOLT 3/8-16
3	532 42 88-67	SCREW 5/16-18 X .750

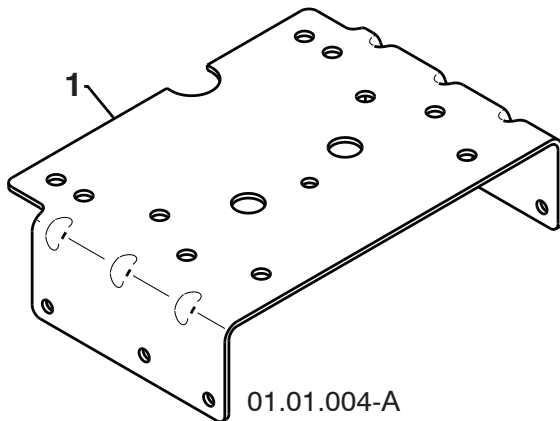

01.01.004-A

KEY NO.	PART NO.	DESCRIPTION
1	532 42 92-69	ENGINE MOUNTING PLATE

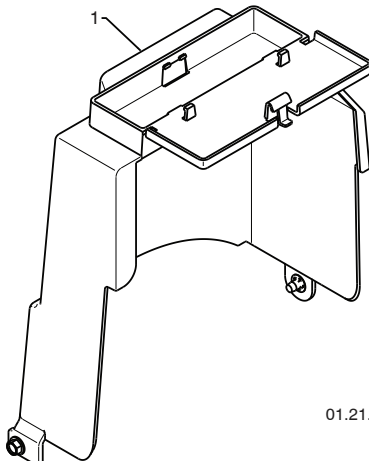

01.21.014-C

KEY NO.	PART NO.	DESCRIPTION
1	532 42 86-85	COVER ASSEMBLY

NOTE: All component dimensions given in U.S. inches. 1 inch = 25.4 mm
IMPORTANT: Use only Original Equipment Manufacturer (O.E.M.) replacement parts.
 Failure to do so could be hazardous, damage your snow thrower and void your warranty.

REPAIR PARTS

CHASSIS / ENGINE / PULLEYS

SNOW THROWER - MODEL NO. 12527SB (96193005600), PRODUCT NO. 961 93 00-56

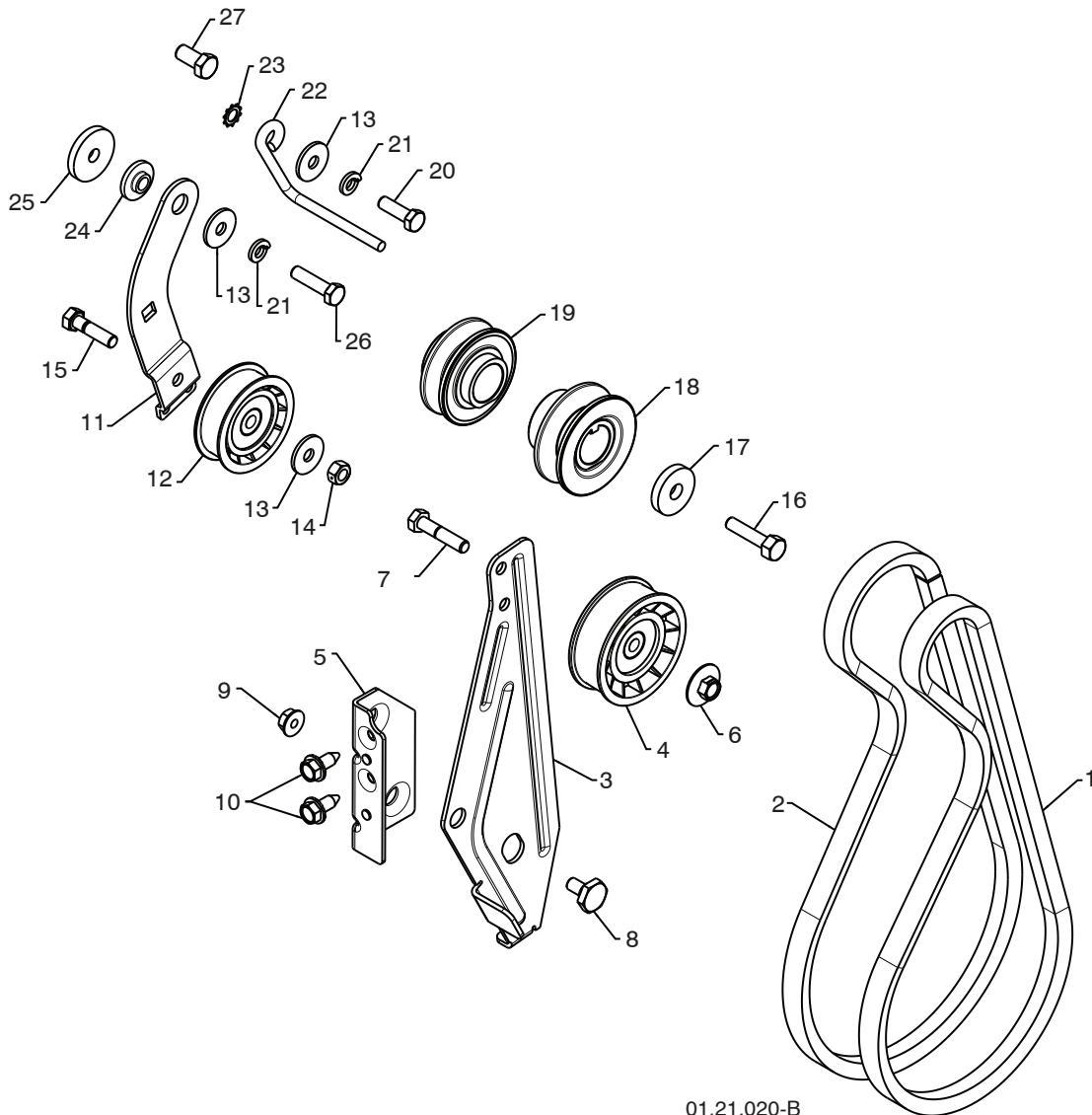

01.21.020-B

KEY NO.	PART NO.	DESCRIPTION	KEY NO.	PART NO.	DESCRIPTION
1	532 41 98-88	IMPELLER BELT	15	874 78 05-20	SCREW 5/16-18 X 1.25
2	532 42 73-04	TRACTION BELT	16	532 85 10-84	SCREW 3/8-24 X 1 .375
3	532 43 58-02	IDLER ARM BRACKET	17	819 13 20-05	WASHER
4	532 18 05-23	IDLER PULLEY	18	532 42 59-34	PULLEY ENG IMPELLER
5	532 43 58-01	IDLER BRACKET	19	532 42 59-33	PULLEY ENG TRACTION
6	532 42 65-89	NUT 5/16-18	20	874 61 05-16	SCREW 5/16-24 X 1.00
7	874 78 05-24	SCREW 5/16-18 X 1.50	21	810 04 05-00	LOCKWASHER 5/16
8	532 42 42-97	SHOULDER BOLT 5/16-18 X .50	22	532 15 54-52	BELT GUIDE
9	532 75 11-53	NUT 5/16-18 LOCK	23	811 05 05-00	LOCKWASHER 5/16
10	532 42 88-67	SCREW 5/16-18 X .750	24	532 17 53-31	IDLER BUSHING
11	532 42 75-76	TRACTION IDLER BRACKET	25	819 11 22-06	WASHER
12	532 18 05-22	TRACTION PULLEY	26	874 61 05-20	SCREW 5/16-24 X 1.25
13	532 05 92-89	WASHER	27	874 76 06-08	SCREW 3/8-16 X .750
14	873 80 05-00	NUT 5/16-18			

NOTE: All component dimensions given in U.S. inches. 1 inch = 25.4 mm

IMPORTANT: Use only Original Equipment Manufacturer (O.E.M.) replacement parts. Failure to do so could be hazardous, damage your snow thrower and void your warranty.

REPAIR PARTS

WHEELS

SNOW THROWER - MODEL NO. 12527SB (96193005600), PRODUCT NO. 961 93 00-56

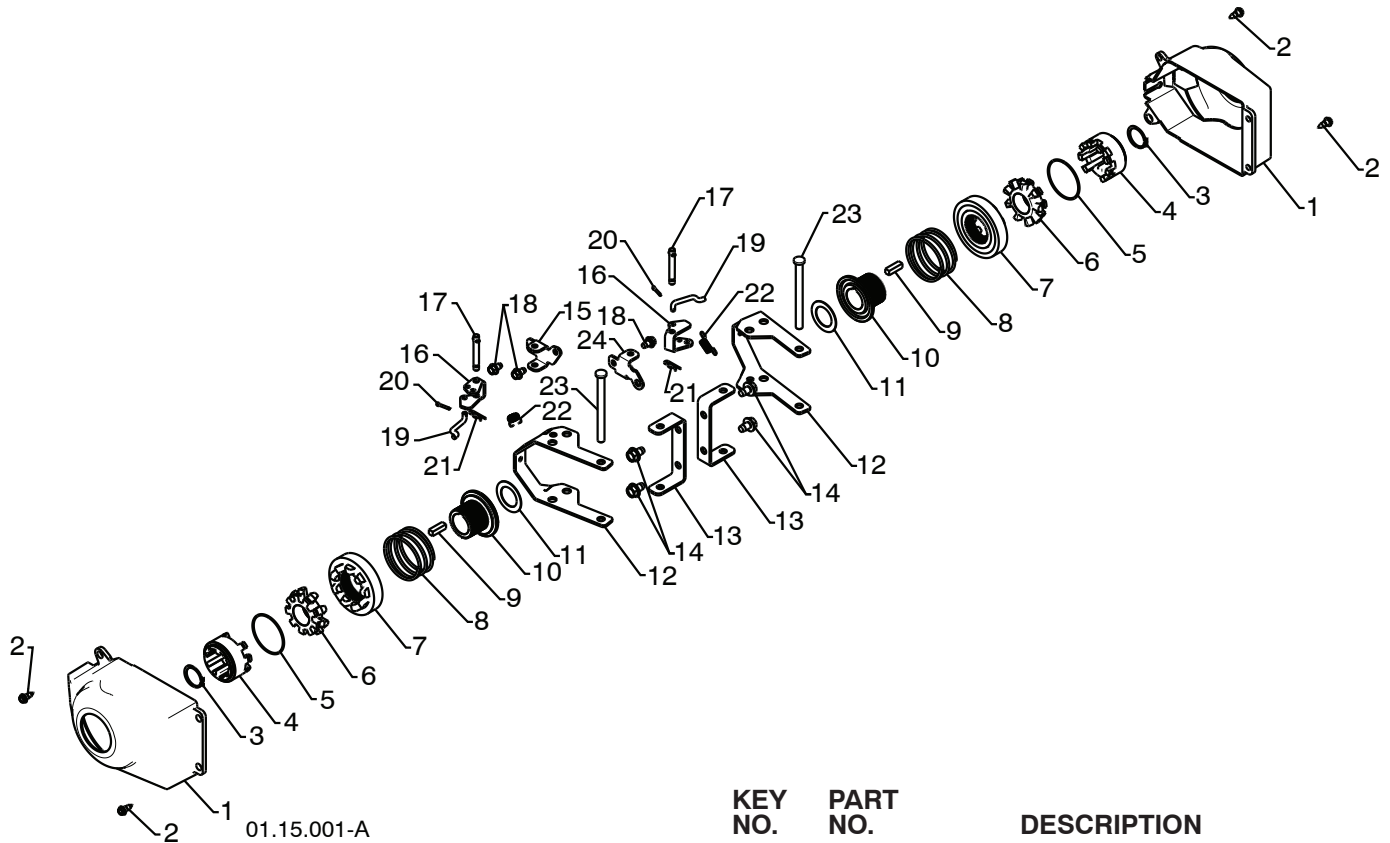

KEY NO.	PART NO.	DESCRIPTION
1	532 40 51-61	COVER
2	532 18 44-71	SHOULDER SCREW
3	812 00 00-45	RETAINER RING
4	532 19 21-26	WHEEL DRIVER
5	532 18 24-66	RETAINER RING
6	532 18 76-22	WHEEL LOBE
7	532 19 49-41	CLUTCH SLIDE
8	532 17 91-39	SPRING
9	532 18 92-82	SQUARE KEY
10	532 19 49-40	AXLE LOBE
11	532 17 46-97	THRUST WASHER
12	532 43 58-25	STEERING YOKE
13	532 43 58-23	STEERING BRACKET
14	817 49 05-08	SCREW 5/16-18 X .50
15	532 19 95-11	PIVOT BRACKET
16	532 19 95-18	BELLCRANK
17	532 18 18-47	BELLCRANK PIN
18	817 60 04-06	SCREW 1/4-20 X .375
19	532 40 50-77	STEERING LINK
20	532 70 02-79	RETAINER
21	532 08 51-79	RETAINER
22	532 19 38-85	SPRING
23	532 18 20-15	LEVER PIN
24	532 19 95-12	PIVOT BRACKET

NOTE: All component dimensions given in U.S. inches. 1 inch = 25.4 mm
IMPORTANT: Use only Original Equipment Manufacturer (O.E.M.) replacement parts.
 Failure to do so could be hazardous, damage your snow thrower and void your warranty.

REPAIR PARTS

WHEELS

SNOW THROWER - MODEL NO. 12527SB (96193005600), PRODUCT NO. 961 93 00-56

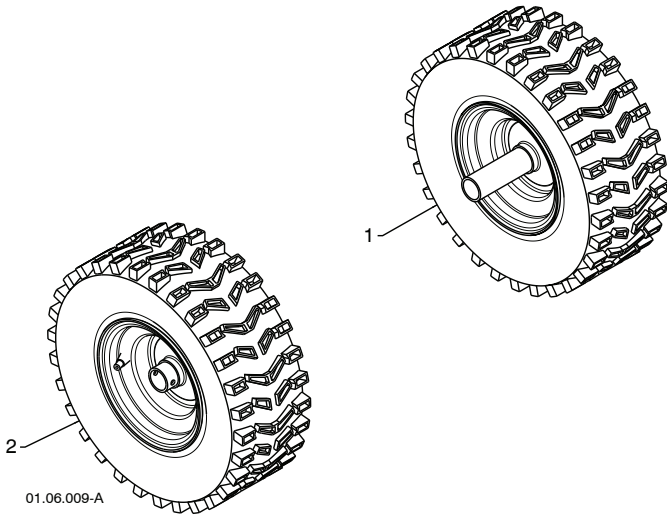

KEY NO.	PART NO.	DESCRIPTION
1	532 43 62-53	WHEEL 16 X 4.80 X LH
2	532 43 62-54	WHEEL 16 X 4.80 X RH

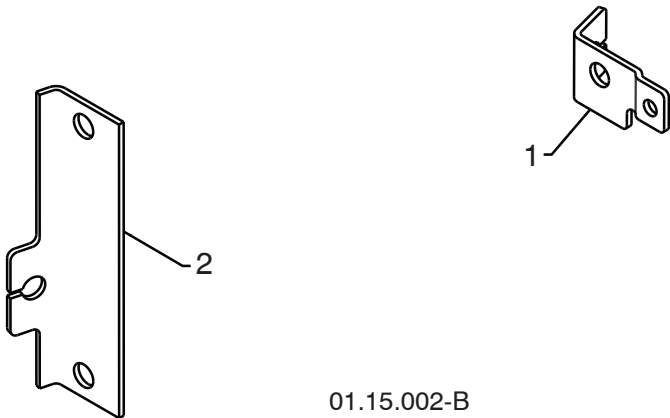

KEY NO.	PART NO.	DESCRIPTION
1	532 43 58-27	STEER CABLE BRACKET LH
2	532 43 58-26	STEER CABLE BRACKET RH

NOTE: All component dimensions given in U.S. inches. 1 inch = 25.4 mm
IMPORTANT: Use only Original Equipment Manufacturer (O.E.M.) replacement parts.
 Failure to do so could be hazardous, damage your snow thrower and void your warranty.

REPAIR PARTS

BAG OF PARTS

SNOW THROWER - MODEL NO. 12527SB (96193005600), PRODUCT NO. 961 93 00-56

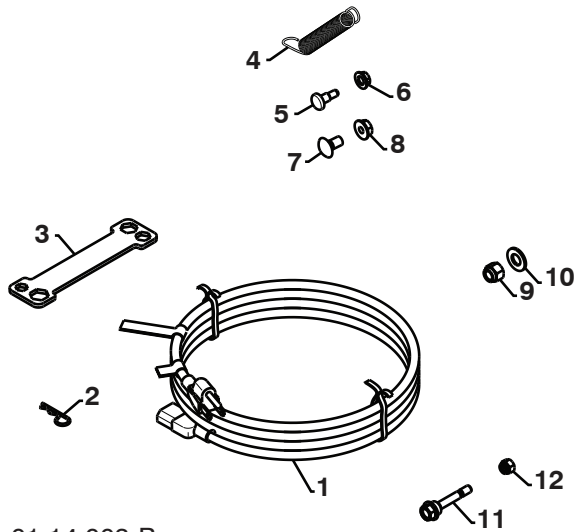

KEY NO.	PART NO.	DESCRIPTION
1	532 19 85-63	POWER CORD
2	532 16 96-75	RETAINER PIN
3	532 42 91-12	WRENCH
4	532 18 45-05	REMOTE SPRING
5	532 17 98-29	SHOULDER BOLT 1/4-20
6	532 19 17-30	LOCKNUT 1/4-20
7	872 25 05-05	CARRIAGE BOLT 5/16-18 X 5/8
8	532 75 11-53	LOCKNUT 5/16-18
9	873 80 06-00	LOCKNUT 3/8-16
10	919 13 13-16	WASHER 3/8
11	532 19 20-90	SHEAR BOLT 1/4-20 X 1-13/16
12	873 80 04-00	LOCKNUT 1/4-20

01.14.003-B

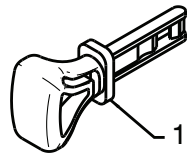

01.14.009-A

1	532 42 26-63	SAFETY IGNITION KEY
---	--------------	---------------------

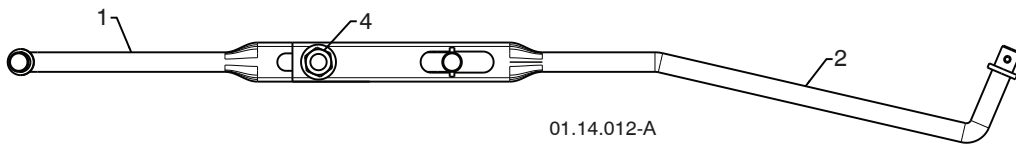
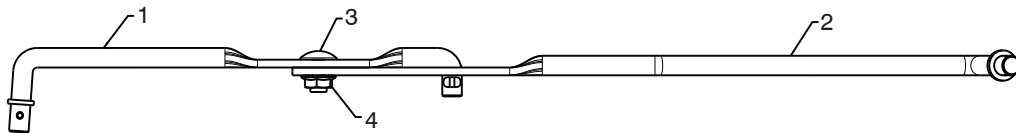

01.14.012-A

KEY NO.	PART NO.	DESCRIPTION
1	532 18 04-45	SHIFTER ROD TOP
2	532 18 77-16	SHIFTER ROD BOTTOM
3	872 27 05-05	CARRIAGE BOLT 5/16-18 X .75
4	532 15 53-77	NUT 5/16-18

NOTE: All component dimensions given in U.S. inches. 1 inch = 25.4 mm
IMPORTANT: Use only Original Equipment Manufacturer (O.E.M.) replacement parts.
 Failure to do so could be hazardous, damage your snow thrower and void your warranty.

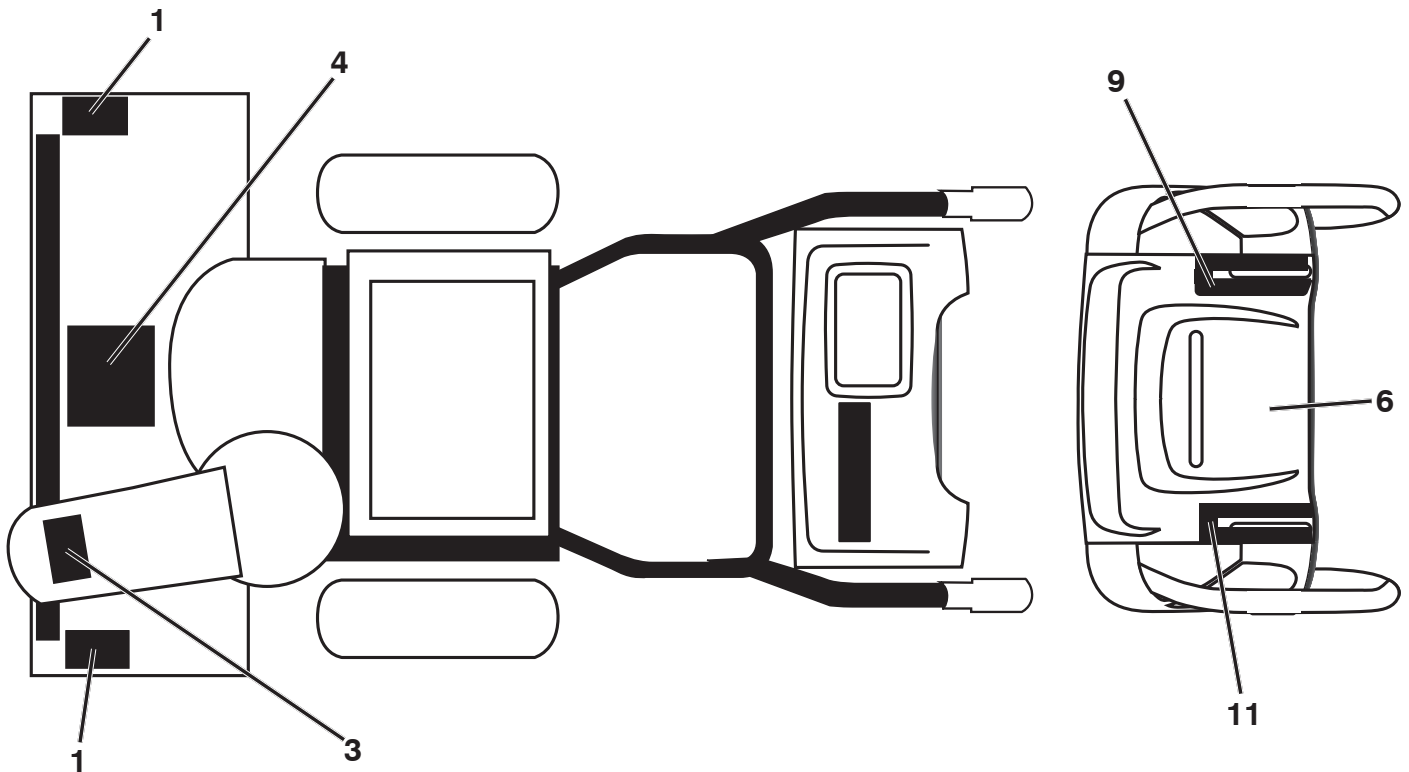

KEY NO.	PART NO.	DESCRIPTION
1	532 18 10-37	DECAL, DANGER
3	532 18 10-35	DECAL, DANGER, DEFLECTOR
4	532 18 10-42	DECAL, DANGER
6	532 42 95-73	DECAL, INSTRUCTION
9	532 42 95-71	DECAL, RH TRIGGER
11	532 42 95-69	DECAL, LH TRIGGER
--	532 43 56-32	OPERATOR'S MANUAL, ENGLISH
--	532 43 56-33	OPERATOR'S MANUAL, FRENCH

NOTE: All component dimensions given in U.S. inches. 1 inch = 25.4 mm
IMPORTANT: Use only Original Equipment Manufacturer (O.E.M.) replacement parts.
 Failure to do so could be hazardous, damage your snow thrower and void your warranty.

Free Manuals Download Website

<http://myh66.com>

<http://usermanuals.us>

<http://www.somanuals.com>

<http://www.4manuals.cc>

<http://www.manual-lib.com>

<http://www.404manual.com>

<http://www.luxmanual.com>

<http://aubethermostatmanual.com>

Golf course search by state

<http://golfingnear.com>

Email search by domain

<http://emailbydomain.com>

Auto manuals search

<http://auto.somanuals.com>

TV manuals search

<http://tv.somanuals.com>